



Alberti digital on portuguese architecture: shape grammar transformations as a computational framework to determine the influence of Alberti legacy on portuguese renaissance churches

Autor(es): Figueiredo, Bruno; Sousa, Luís; Duarte, José P.; Krüger, Mário

Publicado por: Editorial do Departamento de Arquitetura

URL persistente: URI:<http://hdl.handle.net/10316.2/37232>

DOI: DOI:http://dx.doi.org/10.14195/1647-8681_5_4

Accessed : 17-May-2017 10:26:21

A navegação consulta e descarregamento dos títulos inseridos nas Bibliotecas Digitais UC Digitalis, UC Pombalina e UC Impactum, pressupõem a aceitação plena e sem reservas dos Termos e Condições de Uso destas Bibliotecas Digitais, disponíveis em <https://digitalis.uc.pt/pt-pt/termos>.

Conforme exposto nos referidos Termos e Condições de Uso, o descarregamento de títulos de acesso restrito requer uma licença válida de autorização devendo o utilizador aceder ao(s) documento(s) a partir de um endereço de IP da instituição detentora da supramencionada licença.

Ao utilizador é apenas permitido o descarregamento para uso pessoal, pelo que o emprego do(s) título(s) descarregado(s) para outro fim, designadamente comercial, carece de autorização do respetivo autor ou editor da obra.

Na medida em que todas as obras da UC Digitalis se encontram protegidas pelo Código do Direito de Autor e Direitos Conexos e demais legislação aplicável, toda a cópia, parcial ou total, deste documento, nos casos em que é legalmente admitida, deverá conter ou fazer-se acompanhar por este aviso.



JOELHO

05

DIGITAL ALBERTI: TRADITION AND INNOVATION

—
Coordination:

Mário Krüger

José P. Duarte

Gonçalo Canto Moniz

Terry Knight

Marta Oliveira

José António Bandeirinha

Mário D'Agostino /

Andrea Loewen

Digital Alberti Exhibition

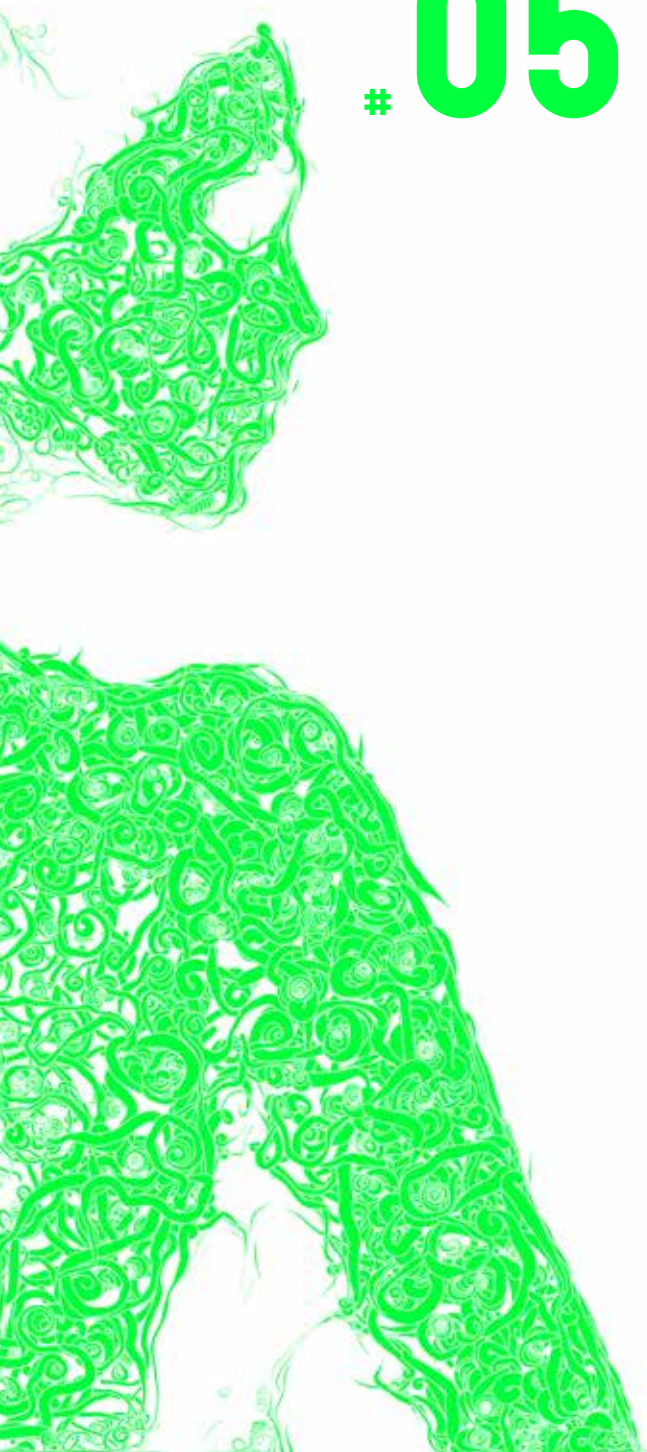

Bruno Figueiredo, Luís Sousa,
José P. Duarte, Mário Krüger

**Alberti Digital on
Portuguese Architecture:
Shape Grammar transformations
as a computational framework
to determine the influence of
Alberti legacy on Portuguese
Renaissance churches**

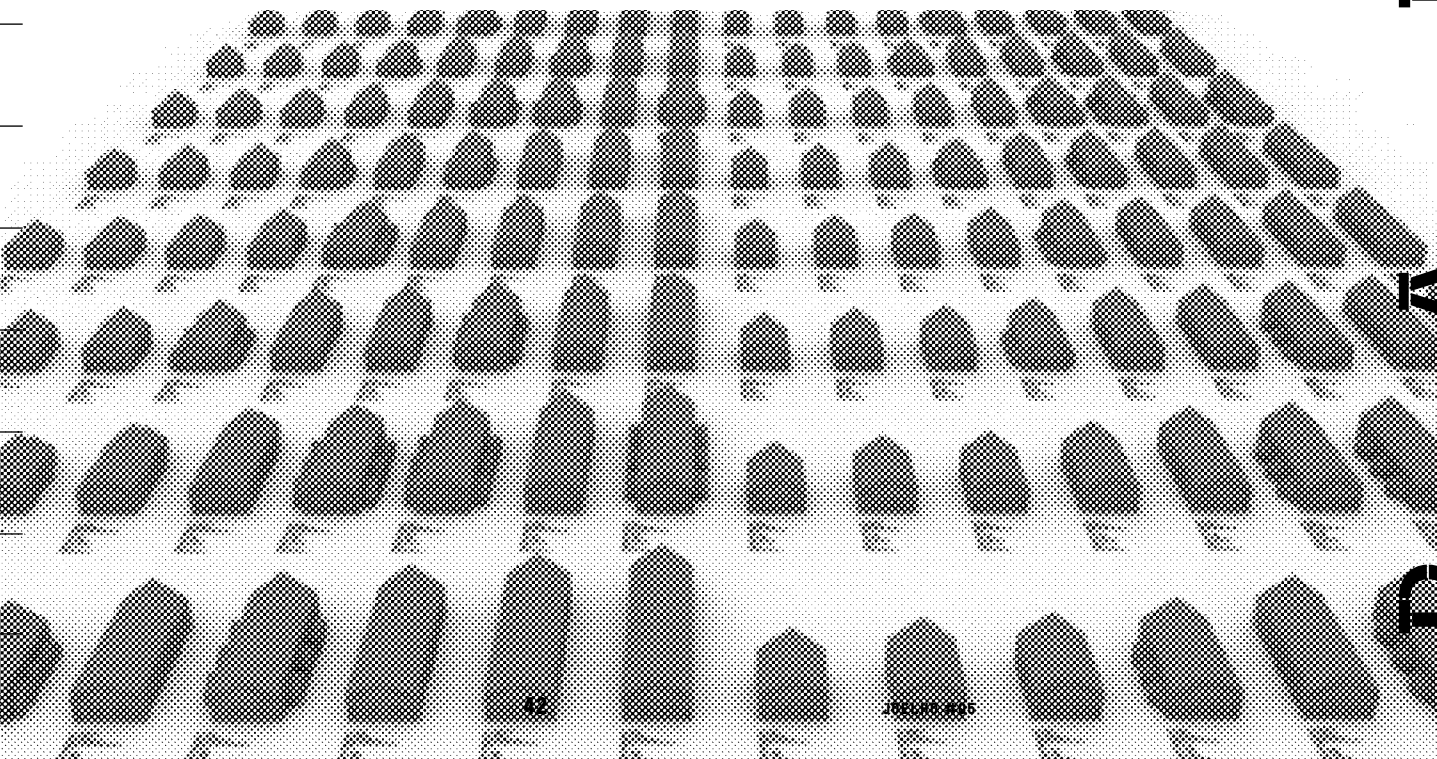

A study on the influx of Leon Battista Alberti (1404-1472) legacy in Portuguese architecture during the Counter-Reformation period is the purpose for the research on which this article is framed. The article focus on the theoretical foundations that permit to translate the *De re aedificatoria* (1485) morphological and proportional descriptions of sacred buildings into a description grammar (Stiny, 1981) and a shape grammar (Stiny and Gips, 1972) and then use it to determine its influence on Portuguese Renaissance architecture.

This research follows the framework on transformations in design proposed by Terry Knight (1983), according to which the transformation of one style into another can be explained by changes applied to the grammar underlying the first style in order to obtain the grammar of the second. Grammars are thus proposed as a complementary tool to be used by architectural historians to test hypotheses raised after documental evidence.

The article reviews the three main stages of this research, presenting the methodology and results achieved in each of these moments. Firstly, it describes the process of inferring an description grammar and shape grammar directly translated from the *De re aedificatoria* (Alberti, 2011) and the analysis of their derivation's outcomes. Although several affinities have been found between the solutions generated by the initial grammar and the Portuguese classical churches, others features remained uncertain. In the context of the research project, it seemed appropriate to consider the morphological and proportional design of Alberti most relevant churches to deduce transformations on the grammar. A set of Portuguese Renaissance sacred buildings were chosen and analyzed under the light of Alberti's theoretical and design rules. This task was assisted by evaluating similarities and differences between them and the recursive structure of the grammar, their rules, and the corpus of solutions derived from it. Finally, in order to achieve a grammar representative of the Portuguese Renaissance sacred buildings, further transformations were introduced on the grammar, gathering rules common to Alberti thoughts with Portuguese specific architectonic principles. Although along the process of grammar transformation several rules were added and the spatial relations were changed, the main recursive structure of the successive grammars was kept.

Methodology

Despite the *editio princeps* of *De re aedificatoria* not containing any illustrations, this fact did not impeded the algorithmic terms in which edificatory rules are described to be key on the definition of a Renaissance architectural language.

With the aim of clarifying the influence from the *editio princeps* on the delineation of Portuguese Renaissance sacred buildings morphology and proportions, the methodology adopted in this research considers two foundational works in the use of analytical shape grammars. The first reference is the Palladian grammar (Stiny, Mitchell, 1978),

PARAMETERS
 Wc tribune width
 Lc tribune Length
 Wcl chapel width
 Lcl chapel length
 Rcl lateral chapels radius
 Ws Skeleton width
 Ncl number of lateral chapels

CONDITIONS
 $Wcl = \varphi Wc$
 $\varphi \in \{11/12, 1\}$
 $Lcl = 1/2 Wcl$
 $Ws = \varphi' Wcl$
 $1/5 \leq \varphi' \leq 1/3 \vee \varphi' = 1/2$
 $Ws = (Li - Ncl Wcl) / (Ncl + 1)$

SCHEMA

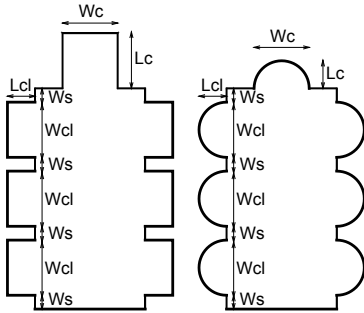

2. Parameters, Conditions and Schemas that represent the knowledge on the lateral chapels described on the Book 7, Chapter IV (4–8).

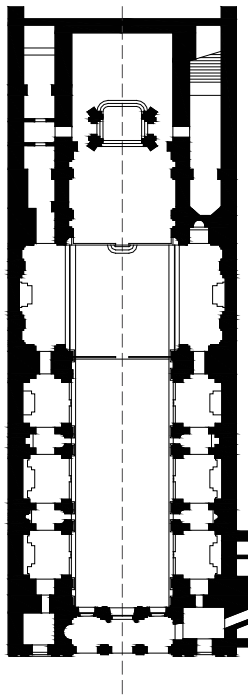

3. Plan of São Vicente de Fora church.

whose inference departs from the analyses of the most representative Palladio Villas. The authors systematized the morphological and proportional knowledge of the Villas that ultimately allowed to define a set of shape rules for the design of the plan outline, partitioning, porticos, internal and external openings. Their application results in the derivation of solutions within the same language. The second reference is the work of Terry Knight (1983, 1994), ultimately published in *Transformations of Languages of Designs*¹, where she establishes a procedure and methodology to explain the evolution of a language in its subsequent one by means of shape grammar transformations.

These works gave us the tools to develop our research. The process occurred in three main stages that follow a recursive trial-and-error process. The first stage is the translation of the treatise descriptions on sacred buildings in a set of parametric schemas, conditions and parameters, resulting in an initial set of shape rules that compose a preliminary shape grammar. Although the generative outcome of this grammar (Duarte et al, 2011; Figueiredo et al, 2013) proved to be successful in computing solutions in the same language, certain characteristics of the Portuguese churches of the Renaissance period are not identifiable in these solutions. This fact led us to transform the grammar by inferring knowledge from Alberti's built work. Again, evaluation and systematization of the divergences between the solutions generated by the second grammar and the Portuguese churches led us to restart the process of transforming the grammar in to a subsequent one that reflects the specificity of both Alberti and Portuguese Renaissance architecture.

A shape grammar to generate temples in accordance with Alberti theory

De re aedificatoria describes temples in algorithmic terms; that knowledge is mainly prescribed on the Chapters IV and V of Book 7 – *Ornament to Sacred Buildings*, Chapters V – and Chapter VI of Book IX – *Ornament on Private Buildings*. The proportions and numbers of the temples are closely tied to the column system proportions, namely while defining the portico. The inference of the temples' shape grammar considers a previous translation of Alberti's column system principles into a shape grammar (Coutinho et al., 2011).

Towards the inference of an initial grammar three main tasks were accomplished: reading of *De re aedificatoria* and selection of parts of the text that describe the various components of the temples inscribed on a rectangular plan; compilation and information grouping into parametric schemas that interpret the temples components descriptions; definition and description from the transformation rules along the various stages from the grammar (Li, 2002) and illustration of the rule application to generate a set of solutions that follow the *De re aedificatoria* architectural rules.

In this first approach to the treatise, we have tried to be as true to the text as possible by following the order of descriptions of the temples' parts. Their overall morphology is defined by: the cell, inner space of the temple, defined by the geometry of their *area*; tribune; the lateral chapels and their skeletons; the portico, informed by the column systems – shaft, base, capital and entablature – and their proportions; the pediment; the walls; the roof; and the main openings. The shape and proportions of the constituent parts were described in notations leading to the definition of a set of parameters, conditions and parametric schemas (fig.1).

After the compilation of these notations a set of shape rules were implemented in four parallel grammars which allow computing different views simultaneously – plan, section, elevation, and axonometry.

Figure 4 shows a step-by-step computation, by applying a shape rule at each step, attaining a plan for a temple, composed by a single nave, a rectangular tribune and a set of six lateral chapels with rectangular shape. Figure 1 shows three-dimensional models of design solutions within the same language, derived by the use of other shape rules or the conditions how they were applied.

From Alberti's buildings to grammar transformation

The church of São Vicente de Fora (1582), located in Lisbon, is the example of a Portuguese church design that best fits the Albertian paradigm. A comparison between its plan (fig.3) and a plan derived by the treatise grammar computation process (fig.4) reveals several similarities between them. Despite the existence of affinities between solutions generated by the initial grammar and the Portuguese classical churches, others features remained uncertain. In accordance with the objectives described in the introduction above, the next phase of the research was the analysis of the most representative sacred buildings by Alberti², with the aim of identifying morphological and proportional relations that were not encoded by the treatise grammar.

Two complementary processes were performed. The first, consisted in filling a survey in which entries collect the buildings' features taking into account the parts of sacred buildings described in the treatise grammar (table 1). The second analysis was to draw schemas that were useful for synthesizing the buildings' proportional and morphological principles, identifying which are absent in the treatise descriptions (fig.5). Those informations were registered on tables gathering the parameters, conditions and spatial relations translated from both the treatise and the buildings thereby allowing to identify similitudes and deviances between them.

As an example of the process, the analysis of Sant'Andrea plan (fig.5) revealed three main aspects that differentiate it from the treatise grammar's generative outcome: the cell proportion of 3:1; the relative proportion of $\sqrt{3}:\sqrt{2}$ between the lateral chapels' openings and the skeleton between them³; the existence of rooms that fill the space between lateral chapels, frontispiece and rear façade.

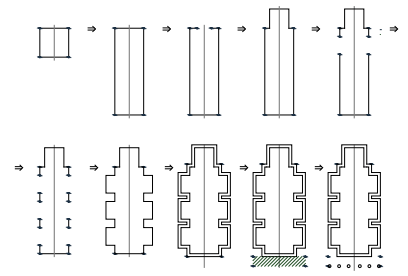

4. Computation of a design solution similar to the church of São Vicente de Fora.

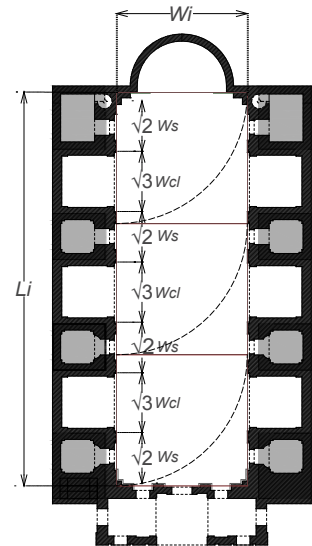

5. Sant'Andrea's plan summarizing the analysis of cell proportions; the skeleton between lateral chapels proportions; the rooms that fill space between chapels.

Cell					
Proportion ($L_i:W_i$) <i>li</i> — area length <i>wi</i> — area width	1:1	3:2	4:3	2:1	3:1
Tribune					
Existence	True	False			
Opening ($W_c:W_i$) <i>wi</i> — area width <i>wc</i> — chapel width	1:2	2:3			
Geometry/Shape	REC	CIR			
Proportion ($L_c:W_c$) <i>lc</i> — chapel length <i>wc</i> — chapel width	1:1	1:2			
Lateral Chapels					
Existence	True	False			
Number N_{cl}	2	6	10		
Geometry	REC	CIR	REC/CIR	CIR/REC	
Width ($W_c:W_{cl}$)	1:1 no data	1:11/12			
Lenght ($L_{cl}:W_{cl}$) <i>Lcl</i> — lateral chapel length <i>Wcl</i> — lateral chapel width	1:1	1:2			
Skeleton ($W_{cl}:W_s$)	(1:1/5 , 1: 1/3)	1:1/2	$\sqrt{3}:\sqrt{2}$		
Wall					
Thickness ($W_e:W_w$) <i>we</i> — temple width (external) <i>tw</i> — wall thickness	1:12	1:9	1:28		
	Main Wall		Chapels Wall		

Table 1. analysis of Church of Sant'Andrea:
cells in light grey verify the *De re aedificatoria*
descriptions, while cells in dark grey are
divergent.

Although the cell and lateral chapel's proportions do not comply with the descriptions in Book 7, it is foreseen in the proportions described in Chapters V and VI of Book 9 – *Ornament on Private Buildings*, where Alberti describes that *concinnitas* can be reached by the use of musical consonances and *correspondentiae inatae*. This fact made us to incorporate these numbers in the initial conditions of shape *Rule 1 (fig.6a) and Rule4 (fig.6b)*.

In Sant'Andrea, the spaces in between the row of lateral chapels and the edges of the frontispiece and rear façade are conformed by a rectangular room which is also connected to the cell. Since this spatial relation was not considered in *De re aedificatoria*⁴, two new rules were added to the initial set of *Rules 7 (fig.7, center), Rule7a' and Rule7b' (fig.7, right side)* considering the spatial relations existent in Alberti's design.

According to Knight (1983), to transform a shape grammar, at least one rule addition, rule deletion or rule change has to be performed. By taking into consideration her definition of rule change: "Rule change changes a rule, initial shape, or final state by changing any of its spatial or nonspatial components: spatial relations, spatial labels, or state labels." – the operations performed to *Rule1, Rule4 and the set of Rule7* enable the grammar transformation.

Transformations grammar to achieve a Portuguese Renaissance churches grammar in debt to Alberti's legacy

Although this article gives more emphasis to São Vicente de Fora, other significant churches built in the Portuguese territories until the XVIII century are in debt to Alberti's legacy. Those case-studies are also representatives of geographical and morphological diversity including the churches of: Espírito Santo (Évora, 1567-1574), Capela das Onze Mil Virgens (Alcácer do Sal, 1555-1565), São Roque (Lisboa, 1564), Sé Nova de Coimbra (Coimbra 1598-1640), Sé de Goa (Índia, 1564-1652), São Miguel das Missões (Rio Grande do Sul, Brazil, 1735-1747).

The knowledge gathered on surveying and analyzing the most representative Portuguese churches from the Counter-Reformation period was compared with the Alberti's grammar outcomes. This process followed the methodology undertaken previously, further transformations were introduced in the grammar, resulting in a grammar that settled rules common to Alberti thoughts and Portuguese specific architectonic principles. The plan of São Vicente de Fora (*fig.8*) encodes three main features that distinguish it from the shape rules inferred from *De re aedificatoria* and Alberti built work. The most notorious divergence between the Albertian shape rules and the Portuguese church morphology corresponds to the existence of an inscribed transept in the latter (*fig.8a*). Accordingly to Robert Tavernor (1998) the transept of Sant'Andrea is a later modification which does not belong to Alberti's intentions, reason why we did not introduced it the Albertian vocabulary.

R1 Initial Rule - area definition

plan

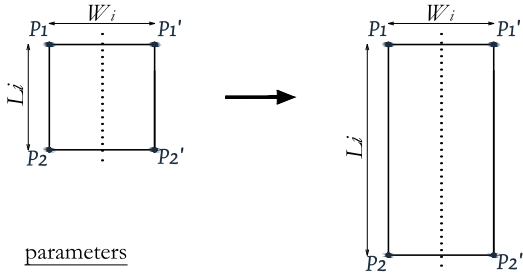

parameters

L_i - area length
 W_i - area width

conditions

$L_i = \alpha W_i$
 $\alpha \in \{1, 1\ 1/3, 1\ 1/2, 2, 2\ 1/4, 1\ 7/9, 3, 2\ 2/3, 4, \sqrt{2}/\sqrt{1}, \sqrt{3}/\sqrt{2}, \sqrt{3}/\sqrt{1}, \sqrt{4}/\sqrt{3}\}$

R4b lateral chapels opening

plan

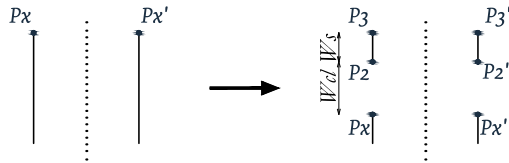

parameters

W_c - chapel width
 W_{cl} - lateral chapels width
 W_s - skeleton width

conditions

$W_{cl} = \varphi W_c; \varphi \in \{11/12, 1\}$
 $W_s = \varphi' W_{cl}$
 $1/5 \leq \varphi' \leq 1/3 \vee \varphi' = 1/2 \vee \varphi' \in \{\sqrt{2}/\sqrt{1}, \sqrt{3}/\sqrt{2}, \sqrt{3}/\sqrt{1}, \sqrt{4}/\sqrt{3}\}$

6. Shape rules from the rectangular temples grammar, with the included parameters and conditions: (a) Rule 1 defines cell proportions; (b) Rule 4b defines the lateral chapels' openings and places labels to design the chapel's outline using the set of Rules 5.

R7 lateral chapels walls connections (rectangular)

plan

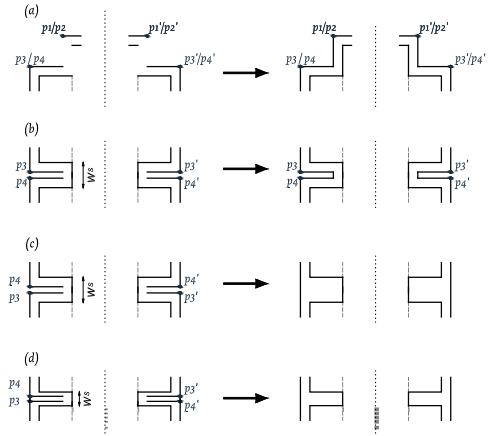

7. Shape rules that define the addition and arrangement of walls in lateral rectangular chapels. The lower rules represent the rules added to the set of Rules 7, in accordance with the spatial relation inferred from Sant'Andrea.

Other divergence represents an evolution from a spatial relation original to Sant'Andrea. In São Vicente de Fora, the chambers located between lateral chapels have doors connecting the chapels (fig.8a), allowing to traverse the church without entering in the ceremonial space. This spatial relation was introduced by Giacomo Vignola (1507-1573) in the design of Gesù (Rome, 1568), which became a prototype for all the Jesuit churches, namely in Portugal.

Finally, the portico of the main façade of São Vicente de Fora hosts two towers, one in each side of the main entrance portico. This configuration was not prescribed in the Alberti grammar. Thus we add a new shape rule enabling the incorporation of those spaces in the plan of churches, a complement to the initial Albertian descriptions on the portico (Fig.9).

The solely evaluation from the ability of the Albertian grammar to derivate the plan of São Vicente de Fora occasioned the addition of three new shape rules to the previous grammar. Although this fact gave more options of composition, some very dissimilar to Alberti proposals, the recursive structure of the Albertian grammar has not changed along the grammar transformations. It was also possible to verify that the most common features in the composition of Portuguese churches and Alberti's prescriptions are the existence of a single nave, a tribune and lateral chapels.

Conclusion

This article shows that the main features of Alberti buildings, such as Sant'Andrea church, follow the morphological and proportional knowledge described in the *De re aedificatoria*. Moreover, it argues for the existence of morphological correspondences between the plan of Sant'Andrea church, an original model that became a prototype for Renaissance churches, and several Portuguese churches from the XVI and XVII centuries.

Although São Vicente de Fora church is the most representative example, the Jesuit Missions in Portugal mainland and overseas adopted a similar model to their enterprise. The plan of Jesuit churches such as the church of Espírito or the church of São Roque, among others, reveal the plan of the foundational church of Gesù. Similitudes between the plan of Gesù and Sant'Andrea proves the influence of Alberti on the definition of the Jesuit edificatory canon. Even if we cannot prove that Portuguese Renaissance churches were directly influenced by Alberti design to Sant'Andrea, it is difficult to deny an influence via the circulation of the Jesuit prototype.

The variety of context in which Portuguese classical churches were raised results in a very specific knowledge that can be retrieved from them. The possible definition of a grammar portraying their language is feasible because it was originated in transformations of a previous grammar, the Alberti sacred buildings grammar.

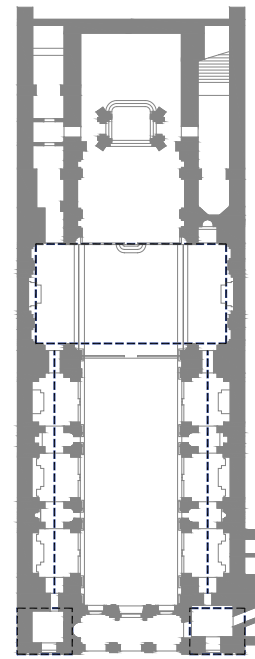

8. Plan of São Vicente de Fora church divergences from the Albertian canon.

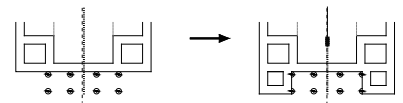

9. New shape rule considering São Vicente de Fora entrance space configuration.

The methodology presented for the inference of transformations contributed for encoding new knowledge into the grammar. The analysis of the Portuguese churches enlighten edificatory principles which easily fit on the structure of the previous shape grammar.

Although the algorithmic nature of the treatise descriptions eased the task of matching building proportions and morphology with the grammar shape rules, the research presented here reinforces the notion that inferring rules from the analysis of a corpus of existing buildings is an adequate tool to reinforce a grammar's capability for generating solutions in accordance to both textual and design descriptions (Mitchell, 1990).

Acknowledgements

This work is funded by FEDER Grants through COMPETE – Programa Operacional Factores de Competitividade and by National Grants through FCT – Fundação para a Ciência e a Tecnologia, as part of the “Digital Alberti” project (PTDC/ AUR-AQI/108274/2008 – FCOMP-01-0124-FEDER-008842). The project was hosted by CES at the University of Coimbra and ICIST at the Technical University of Lisbon, and coordinated by Mário Krüger. Bruno Figueiredo is funded by FCT with PhD grant DFRH -SFRH/BD/69910/2010.

The evolution of this work is in debt with Prof.Terry Knight due to her immensely helpful comments.

- 1 → Terry Knight examines examples as diverse as the evolution of geometrical ornaments painted on ceramic artifacts in ancient Greece; the evolution of painting series from *De Stijl* artists Georges Vantongerloo and Fritz Glarner; and the transformation of Frank Lloyd Wright prairie houses designs into the Usonian houses.
- 2 → This task was focused on the analysis of Alberti's designs of sacred buildings. Namely, the church of Sant'Andrea in Mantua, rebuilt according to Alberti's 1470 design for Ludovico Gonzaga; the church of San Sebastiano in Mantua, 1460, designed in a Greek cross plan, in consonance with Antonio Labacco drawings (Tavernor, 1996, p.128), to which Alberti planned the construction of a dome in the central space, instead of the existing coved vaults; the external walls of the church of San Francesco, known as the Temple Malatestiano in Rimini, begun in 1453, unfinished, and mainly rebuilt after being severely damaged during World War II; and finally, the facade of Santa Maria Novella in Florence (1458-70) which resulted from a commission of the Rucellai family.
- 3 → Several authors (Tavernor, 1985; Krüger, 2011) showed that the use of the proportion $\sqrt{3}:\sqrt{2}$ to design the chapels' openings and the skeleton could be considered Albertian by introducing the use of *correspondentiae inatae* in the definition of such a proportion.
- 4 → While the addition of one single chapel per facade, as it happens in San Sebastiano, results in a relatively evident spatial relation between lateral chapels and the cell's wall, when several chapels are added to the same facade, such a spatial relation can be configured in several ways.

References

- Alberti, L. B. (2011). *Da Arte Edificatória*. Arnaldo Espírito Santo. trans; intr. and notes by Mário Júlio Teixeira Krüger. Lisbon: Calouste Gulbenkian Foundation [1485].
-
- Coutinho, F., Castro e Costa, E., Duarte, J.P. & Krüger, M. (2011). A computational interpretation of *De re aedificatoria*: Translating Alberti's column system into a shape grammar. *Respecting Fragile Places—29th eCAADe Conference Proceedings*, 788–798.
-
- Figueiredo, B., Castro e Costa, E., Duarte, J.P. & Krüger, M. (2013). Digital Temples: a Shape Grammar to Generate sacred buildings according to Alberti's theory. *Future Traditions*, 63–70.
-
- Figueiredo, B., Duarte, J.P. & Krüger, M. (2013). *Albertian Grammatical Transformations*. *eCAADe 2013: Computation and Performance*, 687–696.
-
- Li, Ai. (2002). Algorithmic architecture in twelfth-century China: the yingzao fashi. In F. Rodrigues & K. Williams (Eds.), *Nexus IV: architecture and mathematics* (pp.141–150). Fucechchio, Italy: Kim Williams Books.
- Mithcell, W. (1990). *The Logic of Architecture: Design, Computation and Cognition*. Cambridge, Massachusetts: The MIT Press.
-
- Krüger, M., Duarte, J.P., & Coutinho, F. (2011). Decoding *De Re Aedificatoria*: using grammars to trace Alberti's influence on Portuguese classical architecture. *Nexus Network Journal*, 13, no. 1, 171-182.
-
- Knight, T.W. (1983). *Transformations of language of design*. *Environment and Planning B: Planning and Design* 10, 125-177.
-
- Knight, T.W. (1994). *Transformations in design*. Cambridge, UK: Cambridge University Press.
-
- Rykwert, J., Leach, N. & Tavernor, R. (1988). *On the Art of Building*. *De Re Aedificatoria*. Cambridge, Massachusetts: The MIT Press.
-
- Silva, J.H.P. (1986). *Estudos Sobre o Maneirismo*. Lisboa: Estampa.
- Stiny, G., Gips, J. (1972). Shape grammars and the generative specification of painting and sculpture. *Information Processing* 71. 1460–1465.
-
- Stiny, G., Mitchell, W.J. (1977). The Palladian grammar. *Environment and Planning B: Planning and Design*, Volume 5. 5–18.
-
- Stiny, (1981). A note on the description of designs, *Environment and Planning B: Planning and Design*, Volume 8. 257–267.
-
- Tavernor, R., (1998). *On Alberti and the Art of Building*. New Haven, Connecticut: Yale University Press.