

Em primeiro lugar gostaria de deixar um profundo agradecimento ao Dr. Paulo Rodrigues Santos pela oportunidade que me deu em trabalhar com a sua equipa no Instituto de Imunologia da Faculdade de Medicina da Universidade de Coimbra, por me ter apoiado, confiado em mim, e por me ter disponibilizado todos os meios sem os quais a realização desta tese não teria sido possível.

Em segundo lugar, gostaria de agradecer ao Professor Doutor Paulo Martins dos Santos por ter aceitado o papel de co-orientador e por me ter ajudado na altura em que mais necessitei.

Gostaria ainda de deixar um agradecimento ao Professor Doutor Manuel Santos Rosa, Diretor do Instituto de Imunologia da Faculdade de Medicina da Universidade de Coimbra, pela oportunidade de realizar o presente trabalho nos seus laboratórios.

Um agradecimento especial para a Professora Doutora Helena Sá, pela possibilidade de integrar a sua linha de investigação, pelo apoio na componente clínica, por toda a ajuda e pelos valiosos conselhos. De igual forma, a colaboração clínica da Dra Rita Leal foi essencial para elaborar este trabalho.

À Dra. Vera Alves, pela sua simpatia, amizade e sabedoria inestimáveis, sem os quais a realização desta tese certamente não teria sido possível.

À Dra. Patrícia Couceiro, por ser mais que uma colega, mais que uma amiga. Por todos os conselhos, toda a ajuda nos momentos mais difíceis. Por me ter acolhido de braços abertos, e por me ter dado toda a motivação durante a realização desta tese, a minha maior gratidão.

Ao futuro Mestre Marco Oliveira, um agradecimento especial pela sua amizade e companhia.

Aos meus restantes colegas de laboratório, Mestre Jani Almeida, Doutoranda Priscila Mazini, por toda a ajuda, um muito obrigado.

Gostaria ainda de agradecer a todos os meus amigos, que direta ou indiretamente contribuíram para a realização deste trabalho. Sem vocês, este trabalho teria sido feito três vezes mais depressa, mas não teria valido a pena. Um especial agradecimento à Carina pela paciência e pelo enorme apoio.

Por fim, gostaria de agradecer a toda a minha família, em especial aos meus pais e à minha tia Ana Luísa, por não só tornarem possível esta etapa da minha vida, mas também por sempre acreditarem em mim e me apoiarem de forma incondicional. A minha eterna Gratidão.



**Index of Contents**

<b>I</b>	<b>Abstract .....</b>	<b>1</b>
<b>II</b>	<b>Introduction .....</b>	<b>5</b>
1	Immune system .....	7
1.1	Innate immunity .....	8
1.1.1	Monocytes.....	9
1.1.1.1	Dendritic cells .....	10
1.1.2	NK cells .....	11
1.2	Adaptive immunity .....	14
1.2.1	T cells.....	14
1.2.2	$\gamma\delta$ T cells .....	18
1.2.3	B Cells .....	19
1.3	Invariant natural killer T cells.....	20
1.4	Complement.....	20
2	Immunology of patients with kidney disease .....	23
3	Renal replacement therapies: Hemodialysis and Peritoneal Dialysis.....	26
<b>III</b>	<b>Objectives .....</b>	<b>27</b>
<b>IV</b>	<b>Materials and Methods .....</b>	<b>31</b>
1	Study populations and samples .....	33
2	Cell Counting .....	33
3	Surface and Intracellular staining for Flow Cytometry .....	33

## Index of Contents

3.1	Surface staining.....	33
3.2	Intracellular staining .....	34
4	Leukocytes isolation and Apoptosis Detection .....	34
5	Flow Cytometry and Analysis.....	35
6	Statistical analysis .....	35
7	Compounds.....	35
<b>V</b>	<b>Results.....</b>	<b>37</b>
1	B cells.....	40
1.1	B cell subsets .....	41
2	T cells .....	47
2.1	T CD4 cell subsets .....	47
2.1.1	T helper cells.....	50
2.1.2	T regulatory cells .....	52
2.2	T CD8 cell subsets .....	54
3	Monocyte subsets .....	57
3.1	Dendritic cells .....	59
4	Invariant NKT and $\gamma\delta$ T cells .....	62
4.1	iNKT cells.....	62
4.2	$\gamma\delta$ T cells.....	65
5	NK cell subsets.....	70
6	Apoptosis and Necrosis detection .....	79

<b>VI Discussion .....</b>	<b>81</b>
1 B cells .....	83
1.1 Decrease of immature B cells in PD and HD lead to an increased production of cytokines	83
1.2 B cell response is impaired by the decrease of memory B cells in PD and HD	83
1.3 Alterations in the Fas/FasL signaling pathway increase susceptibility to infection in HD patients .....	84
2 T cells .....	84
2.1 Switch from memory to effector T CD4 cells promotes inflammation .....	84
2.2 Decrease of Th1 and Th17 cells increases susceptibility to infection in PD and HD patients.....	85
2.3 Increased production of TGF- $\beta$ and IL-10 by regulatory T cells in PD and HD.	86
2.4 Reduced T CD8 central memory cells in PD and HD indicate a differentiation into effector function in response to a pathogen.....	86
3 Monocytes .....	86
3.1 Decrease of monocytes and dendritic cells in HD suggests a debilitated immune response.....	86
4 Invariant Natural Killer T cells and $\gamma\delta$ T cells .....	88
4.1 Alterations in the expression of several surface molecules by iNKT and $\gamma\delta$ T cells promoting inflammation .....	88
5 Natural Killer cells .....	90
5.1 Differences in the expression of NK receptors lead to the production of IFN- $\gamma$ and TNF- $\alpha$ in the HD group.....	90

Index of Contents

<b>VII</b>	<b>Conclusions and Future Perspectives .....</b>	<b>93</b>
<b>VIII</b>	<b>References .....</b>	<b>97</b>

**Index of figures**

<b>Figure 1.</b> The innate and adaptive immune response. ....	8
<b>Figure 2.</b> Mechanism of action of NK cells .....	12
<b>Figure 3.</b> Illustration of the various NK cells receptors. ....	13
<b>Figure 4.</b> Differentiation and maturation of T cells in the thymus .....	15
<b>Figure 5.</b> Overview of the complement cascade .....	22
<b>Figure 6.</b> Immunological alterations resulting of the loss of renal function.....	25
<b>Figure 7.</b> Three-pore model of the peritoneal membrane.....	26
<b>Figure 8.</b> Side Scatter(SSC-A) by Forward Scatter(FSC-A) graph from Flow Cytometry, with the lymphocyte and monocyte gates .....	39
<b>Figure 9.</b> Analysis of the absolute frequency (a) and as a percentage of lymphocytes (b) of B cells in the PD, HD and CTRL groups. One-way ANOVA test was used to compare the different groups .....	41
<b>Figure 10.</b> Analysis of the absolute frequency of <i>naïve</i> B cells (a), transitional <i>naïve</i> B cells (c) and CD10 <sup>+</sup> transitional <i>naïve</i> B cells (e); and <i>naïve</i> B cells as a percentage of B cells (b), transitional <i>naïve</i> B cells as a percentage of <i>naïve</i> B cells (d) and CD10 <sup>+</sup> transitional <i>naïve</i> B cells as a percentage of transitional <i>naïve</i> B cells (f) in the PD, HD and CTRL groups. One-way ANOVA test was used to compare the different groups. ....	42
<b>Figure 11.</b> Analysis of the absolute frequency of Pre-switch Memory B cells (a), Switch Memory B cells (c) and Plasmablast Switch Memory B cells (e); and Pre-switch Memory B cells as a percentage of B cells (b), Switch Memory B cells as a percentage of B cells (d) and Plasmablast Switch Memory B cells as a percentage of Switch Memory B cells (f) in the PD, HD and CTRL groups. One-way ANOVA test was used to compare the different groups.....	44
<b>Figure 12.</b> Analysis of the absolute frequency of CD95 <sup>+</sup> CD95L <sup>-</sup> B cells (a), CD95 <sup>-</sup> CD95L <sup>+</sup> B cells (c) and CD95 <sup>-</sup> CD95L <sup>-</sup> B cells (e); and CD95 <sup>+</sup> CD95L <sup>-</sup> B cells (b), CD95 <sup>-</sup> CD95L <sup>+</sup> B cells (d) and CD95 <sup>-</sup> CD95L <sup>-</sup> B cells(f) as a percentage of B cells in the PD, HD and CTRL groups. One-way ANOVA test was used to compare the different groups. ....	46

**Figure 13.** Analysis of the absolute frequency (a) and as a percentage of CD3 lymphocytes (b) of T CD4 cells in the PD, HD and CTRL groups. One-way ANOVA test was used to compare the different groups. .... 48

**Figure 14.** Analysis of the absolute frequency of Central Memory T CD4 cells (a), Effector T CD4 cells (c) and Effector Memory T CD4 cells (e); and Central Memory T CD4 cells (b), Effector T CD4 cells (d) and Effector Memory T CD4 cells (f) as a percentage of T CD4 cells in the PD, HD and CTRL groups. One-way ANOVA test was used to compare the different groups..... 49

**Figure 15.** Analysis of the absolute frequency (a) and as a percentage of CD4 lymphocytes (b) of Activated T CD4 cells in the PD, HD and CTRL groups. One-way ANOVA test was used to compare the different groups..... 50

**Figure 16.** Analysis of the absolute frequency of Th1 cells (a) and Th17 cells (c); and Th1 cells (b) and Th17 cells (d) as a percentage of T CD4 cells in the PD, HD and CTRL groups. One-way ANOVA test was used to compare the different groups. .... 51

**Figure 17.** Analysis of the absolute frequency of Treg cells (a) and Activated Treg cells (c); and Treg cells as a percentage of T CD4 cells (b) and Activated Treg cells as a percentage of Treg cells (d) in the PD, HD and CTRL groups. One-way ANOVA test was used to compare the different groups. .... 53

**Figure 18.** Analysis of the absolute frequency of IL-10<sup>+</sup> Treg cells (a) and TGF-β<sup>+</sup> Treg cells (c); and IL-10<sup>+</sup> Treg cells (b) and TGF-β<sup>+</sup> Treg cells (d) as a percentage of FoxP3<sup>+</sup> Treg cells in the PD, HD and CTRL groups. One-way ANOVA test was used to compare the different groups..... 54

**Figure 19.** Analysis of the absolute frequency (a) and as a percentage of CD3 lymphocytes (b) of T CD8 cells in the PD, HD and CTRL groups. One-way ANOVA test was used to compare the different groups. .... 55

**Figure 20.** Analysis of the absolute frequency (a) and the percentage in CD8 lymphocytes (b) of Central Memory T CD8 cells in the PD, HD and CTRL groups. One-way ANOVA test was used to compare the different groups. .... 56

**Figure 21.** Analysis of the absolute frequency (a) and as a percentage of total lymphocytes and monocytes(b) of Monocytes in the PD, HD and CTRL groups. One-way ANOVA test was used to compare the different groups. .... 58



- Figure 22.** Analysis of the absolute frequency (a) and as a percentage of total monocytes (b) of Classical Monocytes in the PD, HD and CTRL groups. One-way ANOVA test was used to compare the different groups..... 58
- Figure 23.** Analysis of the absolute frequency (a) and as a percentage of total monocytes (b) of CD95<sup>-</sup> CD95L<sup>-</sup> Monocytes in the PD, HD and CTRL groups. One-way ANOVA test was used to compare the different groups. ns: not significant; \*, \*\*, \*\*\*: statistically significant (\* p<0.05, \*\* p<0.01 and \*\*\* p<0.001 )...... 59
- Figure 24.** Analysis of the absolute frequency (a) and as a percentage of total lymphocytes and monocytes (b) of Dendritic cells in the PD, HD and CTRL groups. One-way ANOVA test was used to compare the different groups. .... 60
- Figure 25.** Analysis of the absolute frequency of Myeloid Dendritic cells (a) and Plasmacytoid Dendritic cells (c); and Myeloid Dendritic cells (b) and Plasmacytoid Dendritic cells (d) as a percentage of Dendritic cells in the PD, HD and CTRL groups. One-way ANOVA test was used to compare the different groups. .... 61
- Figure 26.** Analysis of the absolute frequency (a) and as a percentage of total lymphocytes (b) of iNKT cells in the PD, HD and CTRL groups. One-way ANOVA test was used to compare the different groups. .... 63
- Figure 27.** Analysis of the absolute frequency of CD137<sup>-</sup> CD137L<sup>+</sup> iNKT cells (a), CD62L<sup>+</sup> iNKT cells (c) and CD25<sup>+</sup> iNKT cells (e); and CD137<sup>-</sup> CD137L<sup>+</sup> iNKT (b), CD62L<sup>+</sup> iNKT cells (d) and CD25<sup>+</sup> iNKT cells (f) as a percentage of total iNKT cells in the PD, HD and CTRL groups. One-way ANOVA test was used to compare the different groups..... 64
- Figure 28.** Analysis of the absolute frequency (a) and as a percentage of total lymphocytes (b) of  $\gamma\delta$  T cells in the PD, HD and CTRL groups. One-way ANOVA test was used to compare the different groups. .... 66
- Figure 29.** Analysis of the absolute frequency of CD137<sup>-</sup> CD137L<sup>+</sup>  $\gamma\delta$  T cells (a) and CD137<sup>+</sup> CD137L<sup>-</sup>  $\gamma\delta$  T cells (c); and CD137<sup>-</sup> CD137L<sup>+</sup>  $\gamma\delta$  T cells (b) and CD137<sup>+</sup> CD137L<sup>-</sup>  $\gamma\delta$  T cells (d) as a percentage of total  $\gamma\delta$  T cells in the PD, HD and CTRL groups. One-way ANOVA test was used to compare the different groups. .... 67
- Figure 30.** Analysis of the absolute frequency (a) and as a percentage of total  $\gamma\delta$  T cells (b) of CD25<sup>+</sup>  $\gamma\delta$  T cells in the PD, HD and CTRL groups. One-way ANOVA test was used to compare the different groups. .... 68

**Figure 31.** Analysis of the absolute frequency of CD95<sup>+</sup> CD95L<sup>+</sup> γδ T cells (a) and CD95<sup>+</sup> CD95L<sup>-</sup> γδ T cells (c); and CD95<sup>+</sup> CD95L<sup>+</sup> γδ T cells (b) and CD95<sup>+</sup> CD95L<sup>-</sup> γδ T cells (d) as a percentage of total γδ T cells in the PD, HD and CTRL groups. One-way ANOVA test was used to compare the different groups. .... 69

**Figure 32.** Analysis of the absolute frequency (a) and as a percentage of total lymphocytes (b) of NK cells in the PD, HD and CTRL groups. One-way ANOVA test was used to compare the different groups. .... 70

**Figure 33.** Analysis of the absolute frequency of NK<sup>Bright</sup> cells (a) and NK<sup>Dim</sup> cells T cells (c); and NK<sup>Bright</sup> cells (b) and NK<sup>Dim</sup> cells (d) as a percentage of total NK cells in the PD, HD and CTRL groups. One-way ANOVA test was used to compare the different groups. .... 71

**Figure 34.** Analysis of the absolute frequency (a) and as a percentage of total NK<sup>Bright</sup> cells (b) of NKG2A<sup>+</sup> NKG2C<sup>+</sup> CD94<sup>+</sup> NK<sup>Bright</sup> cells in the PD, HD and CTRL groups. One-way ANOVA test was used to compare the different groups.. .... 72

**Figure 35.** Analysis of the absolute frequency of NKp44 NK<sup>Bright</sup> cells (a) and NKp44 NK<sup>Dim</sup> cells (c); and NKp44 NK<sup>Bright</sup> cells as a percentage of NK<sup>Bright</sup> cells (b) and NKp44 NK<sup>Dim</sup> cells as a percentage of NK<sup>Dim</sup> cells (d) in the PD, HD and CTRL groups. One-way ANOVA test was used to compare the different groups.. .... 73

**Figure 36.** Analysis of the absolute frequency of CD11b<sup>+</sup> CD27<sup>+</sup> NK<sup>Bright</sup> cells (a), CD11b<sup>-</sup> CD27<sup>+</sup> NK<sup>Dim</sup> cells (c) and CD11b<sup>+</sup> CD27<sup>+</sup> NK<sup>Dim</sup> cells (e); and CD11b<sup>+</sup> CD27<sup>+</sup> NK<sup>Bright</sup> cells as a percentage of NK<sup>Bright</sup> cells (b), CD11b<sup>-</sup> CD27<sup>+</sup> NK<sup>Dim</sup> cells as a percentage of NK<sup>Dim</sup> cells (d) and CD11b<sup>+</sup> CD27<sup>+</sup> NK<sup>Dim</sup> cells as a percentage of NK<sup>Dim</sup> cells (f) in the PD, HD and CTRL groups. One-way ANOVA test was used to compare the different groups.. .... 74

**Figure 37.** Analysis of the absolute frequency (a) and as a percentage of total NK cells (b) of CD62L<sup>+</sup> NK cells in the PD, HD and CTRL groups. One-way ANOVA test was used to compare the different groups..... 75

**Figure 38.** Analysis of the absolute frequency of NKp46 NK<sup>Bright</sup> cells (a) and NKp46 NK<sup>Dim</sup> cells (c); and NKp46 NK<sup>Bright</sup> cells as a percentage of NK<sup>Bright</sup> cells (b) and NKp46 NK<sup>Dim</sup> cells as a percentage of NK<sup>Dim</sup> cells (d) in the PD, HD and CTRL groups. One-way ANOVA test was used to compare the different groups. .... 76

**Figure 39.** Analysis of the absolute frequency of IFN-γ-expressing NK<sup>Bright</sup> cells (a), IFN-γ-expressing NK<sup>Dim</sup> cells (c) and TNF-α-expressing NK<sup>Dim</sup> cells (e); and IFN-γ-expressing NK

<sup>Bright</sup> cells as a percentage of total NK <sup>Bright</sup> cells (b), IFN- $\gamma$ -expressing NK <sup>Dim</sup> cells as a percentage of total NK <sup>Dim</sup> cells (d) and TNF- $\alpha$ -expressing NK <sup>Dim</sup> cells as a percentage of total NK <sup>Dim</sup> cells (e) in the PD, HD and CTRL groups. One-way ANOVA test was used to compare the different groups. .... 77

**Figure 40.** Analysis of the absolute frequency of apoptotic lymphocytes (a) and necrotic lymphocytes (c); and apoptotic lymphocytes (b) and necrotic lymphocytes (d) as a percentage of total lymphocytes of in the PD and HD groups. Non-parametric Mann-Whitney test was used to compare the different groups..... 79



## Index of tables

<b>Table I.</b> Summary of the monoclonal antibodies reactivities, respective conjugates, their clone and distributors. ....	35
<b>Table II.</b> B cell populations from PD, HD and CTRL groups, evaluated by flow cytometry, and their distinctive monoclonal antibodies. The groups were analyzed using One-way Anova test. ....	40
<b>Table III.</b> T CD4 cell populations from PD, HD and CTRL groups, evaluated by flow cytometry, and their distinctive monoclonal antibodies. The groups were analyzed using One-way Anova test. ....	47
<b>Table IV.</b> T helper cell populations from PD, HD and CTRL groups, evaluated by flow cytometry, and their distinctive monoclonal antibodies. The groups were analyzed using One-way Anova test. ....	51
<b>Table V.</b> Treg cell populations from PD, HD and CTRL groups, evaluated by flow cytometry, and their distinctive monoclonal antibodies. The groups were analyzed using One-way Anova test. ....	52
<b>Table VI.</b> T CD8 cell populations from PD, HD and CTRL groups, evaluated by flow cytometry, and their distinctive monoclonal antibodies. The groups were analyzed using One-way Anova test. ....	55
<b>Table VII.</b> Monocyte populations from PD, HD and CTRL groups, evaluated by flow cytometry, and their distinctive monoclonal antibodies. The groups were analyzed using One-way Anova test. ....	57
<b>Table VIII.</b> Dendritic cell populations from PD, HD and CTRL groups, evaluated by flow cytometry, and their distinctive monoclonal antibodies. The groups were analyzed using One-way Anova test. ....	60
<b>Table IX.</b> iNKT cell populations from PD, HD and CTRL groups, evaluated by flow cytometry, and their distinctive monoclonal antibodies. The groups were analyzed using One-way Anova test. ....	62

Index of Tables

**Table X.** TCR $\gamma\delta$  cell populations from PD, HD and CTRL groups, evaluated by flow cytometry, and their distinctive monoclonal antibodies. The groups were analyzed using One-way Anova test. .... 65

**Index of Abbreviations**

APC .....	Antigen-Presenting Cell
CD .....	Cluster of Differentiation
CTRL.....	Control group
DAMP .....	Danger-Associated Molecular Patterns
DNA .....	Deoxyribonucleic Acid
EDTA .....	Ethylenediamine Tetraacetic Acid
FoxP3 .....	Forkhead Box Protein 3
FSC.....	Forward Scatter
HD.....	Hemodialysis
HLA.....	Human Leukocyte Antigen
IFN- $\gamma$ .....	Interferon $\gamma$
IL .....	Interleukin
iNKT .....	Invariant Natural Killer T
KIR.....	Killer Immunoglobulin-like Receptor
LDL.....	Low Density Lipoprotein
LIR .....	Leukocyte Inhibitory Receptor
MHC.....	Major Histocompatibility Complex
NK.....	Natural Killer
PAMP .....	Pathogen-Associated Molecular Pattern

## Index of Abbreviations

PBS.....	Phosphate Buffered Saline
PD.....	Peritoneal Dialysis
PMN.....	Polymorphonuclear
PRR.....	Pattern Recognition Receptor
RNA.....	Ribonucleic Acid
ROS.....	Reactive Oxygen Species
SSC.....	Side Scatter
TCR.....	T Cell Receptor
TGF- $\beta$ .....	Transforming Growth Factor $\beta$
Th.....	T helper
TLR.....	Toll-Like receptor
TNF- $\alpha$ .....	Tumor Necrosis factor $\alpha$
Treg.....	Regulatory T



## **I      Abstract**



The aim the present work was to study the alterations in the immune system in patients undergoing renal replacement therapies – peritoneal dialysis (PD) and hemodialysis (HD) – and whether these therapies have a different effect on the immune system.

Renal replacement therapies are processes used in patients with renal impairment to remove waste products from the blood. Peritoneal dialysis is a process by which a dialysis solution is injected into the peritoneal cavity using a percutaneous abdominal catheter across the peritoneum, removing the waste products through a difference in molality. In hemodialysis, patients are connected to a hemodialysis machine, where the blood and dialysate flow across the dialyzer membrane, without concentration equilibration, effectively removing small solutes.

Due to their pathologies, patients undergoing peritoneal dialysis and hemodialysis have an impaired immune system, and are more susceptible to infection. However, these therapies *per se* can also originate an inflammatory state, due to their invasive nature. In order to study which of these therapies has a greater influence on the immune system, a quantification of several leukocyte populations was made by flow cytometry using different fluorescent antibody conjugates.

Analysis of B cell, T cell, Monocytes, Dendritic cells, invariant natural killer T (iNKT) cell,  $\gamma\delta$  T cell and natural Killer (NK) cell populations and surface molecules in peritoneal dialysis, hemodialysis and a healthy control population all point in the direction that patients undergoing renal replacement therapies have a severely impaired immune system. Furthermore, it is also observable that hemodialysis has a slightly greater impact on the immune system, by comparison with peritoneal dialysis.

**Key words:** Peritoneal Dialysis; Hemodialysis; Immune System; Flow Cytometry

O objetivo deste trabalho foi estudar as alterações no sistema imune em pacientes a realizar diferentes terapias de substituição renal – diálise peritoneal e hemodiálise – e avaliar se estas terapias afectam de forma diferente a resposta imune.

## Abstract

As terapias de substituição renal são usadas em doentes com insuficiência renal para remover resíduos do sangue. A diálise peritoneal é um processo pelo qual uma solução de diálise é injectada na cavidade peritoneal através de um cateter percutâneo abdominal, removendo os resíduos através de uma diferença de molalidade. Na hemodiálise, os pacientes são ligados a uma máquina de hemodiálise, onde o sangue e o fluido de diálise fluem através da membrana do dialisador, sem equilíbrio de concentrações, removendo eficazmente pequenos solutos.

Devido às suas patologias, os pacientes com insuficiência têm um sistema imunitário deficiente, e portanto são mais suscetíveis à infecção. No entanto, as próprias terapias de diálise peritoneal e hemodiálise também podem dar origem a um estado inflamatório, devido à sua natureza invasiva. A fim de estudar qual destas terapias tem uma maior influência sobre o sistema imunitário, a quantificação de várias populações de leucócitos foi feita por citometria de fluxo, utilizando diferentes conjugados de anticorpos fluorescentes.

A análise das populações e da expressão de recetores moleculares à superfície das células B, células T, monócitos, células dendríticas, células iNKT, células T  $\gamma\delta$  e células *Natural Killer* em amostras de diálise peritoneal, hemodiálise e uma população de controlo saudável confirmam que os pacientes submetidos às terapias de substituição renal têm o sistema imunológico severamente debilitado. Além disso, também é observável que a hemodiálise tem um impacto ligeiramente maior sobre o sistema imunitário, em comparação com a diálise peritoneal.

**Palavras-chave:** Diálise Peritoneal; Hemodiálise; Sistema Imune; Citometria de Fluxo

## **II Introduction**



## 1 Immune system

Most organisms have developed complex immune defense systems, used to repel invasive microbes that would parasitize or kill them. These immune systems are extremely effective, as severe infections are quite rare. They are however imperfect in the sense that serious infection sometimes do occur, and also, in that immune responses may sometimes injure the host.

The immune system has evolved to protect the host from infections and from cancer. Typically, the immune system is divided into two categories: innate immunity, consisting of physical epithelial barriers, phagocytic leukocytes, dendritic cells, and natural killer (NK) cells; and adaptive immunity, mostly represented by B and T cells (Figure 1). The innate immune system comes into play immediately after the appearance of antigen whereas the adaptive immune system provides antigen-specific response. Innate immunity is the most universal, the most rapidly acting type of immunity. Most organisms survive through innate immune mechanisms alone; only in vertebrates have alternative systems for pathogen recognition and elimination, collectively called adaptive immunity, been evolved. In addition to these defense mechanisms, there are unconventional T cells like the gamma delta ( $\gamma\delta$ ) T lymphocytes and invariant natural killer T (iNKT) cells that functionally and phenotypically belong to both the innate and the adaptive immune system and are able to bridge the two (Parkin & Cohen 2001; Dranoff 2004).

It is widely considered that any “true” immune system, however advanced or primitive, must be capable of doing three things: recognition of a diverse array of pathogens; killing these pathogens once they are recognized; and doing this without damaging the host (Mandal & Viswanathan 2011).

## Introduction

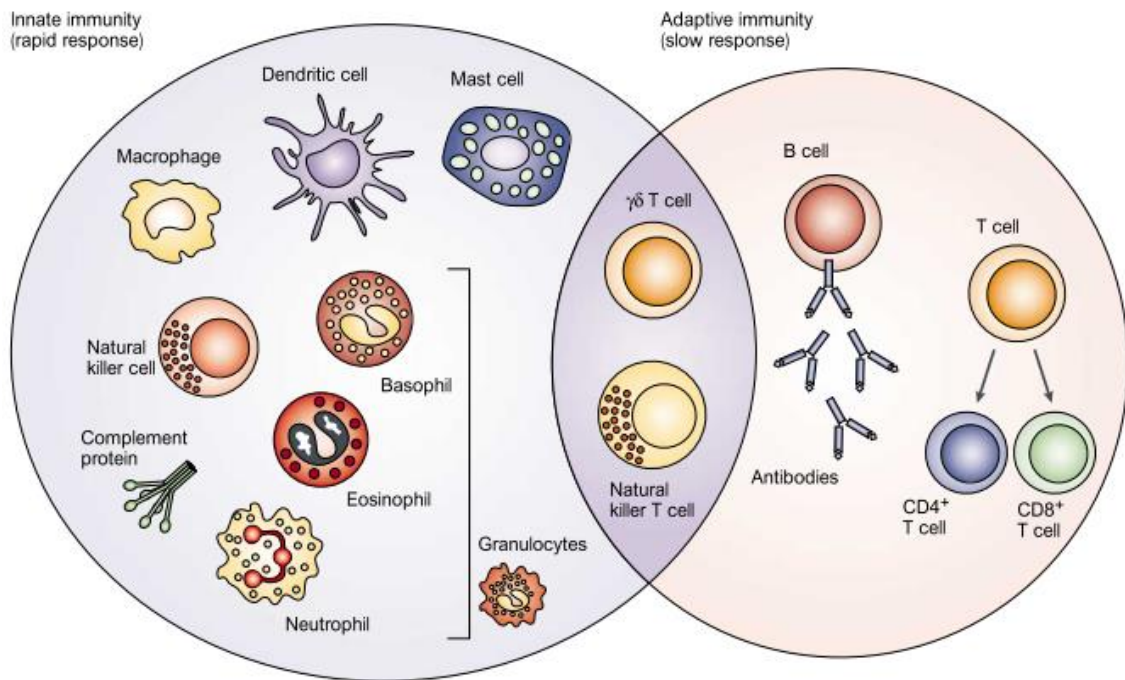

**Figure 1. The innate and adaptive immune response.**

The innate immune response functions as the first line of defense against infection. It encompasses several molecules and cell types, such as complement proteins, granulocytes, mast cells, macrophages, dendritic cells and natural killer cells. The adaptive immune response develops only after antigen presentation, but manifests as increased antigenic specificity and memory. It consists of antibodies, B cells, and CD4<sup>+</sup> and CD8<sup>+</sup> T lymphocytes. Natural killer T cells and  $\gamma\delta$  T cells are cytotoxic lymphocytes that have characteristics of both the innate and adaptive immunity (Dranoff 2004).

### 1.1 Innate immunity

The innate immune system includes cellular and humoral elements that help prevent and contain the infection. This first line of defense is highly effective in preventing most of the early stage infections, eliminating them shortly after the initial contact (Finlay & McFadden 2006).

In vertebrates, innate immunity is largely dependent upon myeloid cells: professional immunocytes that engulf and destroy pathogens. Most of the times, these cells have the ability to carry out their functions independently; however, they have evolved to better function in conjunction with cells and proteins of the adaptive immune system.



Myeloid cells include mononuclear phagocytes and polymorphonuclear (PMN) phagocytes. The PMN phagocytes include neutrophils, basophils, and eosinophils, and are of key importance in the containment of infection. The mononuclear phagocytes encompass the macrophages, and the dendritic cells (both derived from blood monocytes), which are highly efficient at presenting antigens to T cells of the adaptive immune system, as well as an elevated ability for phagocytosis (Beutler 2004; Parkin & Cohen 2001).

Without the vital antigen-presenting function of innate immune cells and without the production of cytokines of innate immune origin adaptive immune responses are ineffective (Beutler 2004).

Generally, the strategy of the innate immune detection is to dedicate a limited number of receptors to the recognition of microbial molecules. The innate immune receptors must detect pathogen molecules of the pathogen, so as to permit interdiction of the infection before microbes proliferate, disseminate, and overwhelm the host. Those receptors must be mostly indifferent to molecules of host origin (the basis of innate immune discrimination between self and non-self). In this regard, Pattern Recognition Receptors (PRRs) are able to recognize Pathogen-Associated Molecular Patterns (PAMPs), which are groups of molecules associated with specific groups of pathogens. In addition, Danger-Associated Molecular Patterns (DAMPs)(Bianchi 2007) and non-pathogenic Microbial-Associated Molecular Patterns (MAMPs) (Pel & Pieterse 2012) are also recognized by PRRs. The discovery of Toll-like receptors (TLRs) changed the focus of immunological research. It is now known that TLRs have the ability to recognize liposaccharides, glycoproteins and nucleic acids and, when activated, can trigger a rapid immune response (Beutler 2004; Bewick et al. 2009).

### **1.1.1 Monocytes**

Monocytes are mononuclear leukocytes, and are a part of the innate immune system.

Monocytes originate from a common monocyte, macrophage and dendritic cell precursor in the bone marrow, and can further differentiate into a range of tissue

macrophages and dendritic cells. These non-proliferative cells are present in the bone marrow and the blood, from where they can migrate to several tissues, like the spleen, liver, lymph nodes, lungs, peritoneal cavity, and the subcutaneous tissue. Monocytes mediate host antimicrobial defense and are also implicated in many inflammatory diseases (Sheel & Engwerda 2012).

Human monocytes are divided into two main subsets, based on the expression of surface CD14 and CD16. CD14<sup>++</sup> CD16<sup>-</sup> monocytes, also referred to as classical monocytes, are the most prevalent monocyte subset in human blood. CD14<sup>+</sup> CD16<sup>+</sup> monocytes are designated as non-classical monocytes. CD14<sup>+</sup> CD16<sup>+</sup> monocytes are considered to be proinflammatory, based on higher expression of proinflammatory cytokines, and to have higher potency in antigen presentation (Shi & Pamer 2011; Ziegler-Heitbrock 2007).

### **1.1.1.1 Dendritic cells**

Dendritic cells are a population of cells that derive from the monocytes and bridge the innate and adaptive immune system. They are able to recognize pathogens using pattern recognition receptors, after which they migrate, to present pathogen-derived antigens to antigen-specific T cells, without directly engaging in effector functions. Dendritic cells can also upregulate co-stimulatory molecules and produce cytokines that drive T cell priming and effector differentiation (Ganguly & Haak 2013).

Dendritic cells are divided in two major classes: plasmacytoid dendritic cells and classical dendritic cells. Without being directly involved in effector activities such as pathogen killing, dendritic cells bridge the innate and adaptive immune systems. Plasmacytoid dendritic cells are capable of detecting foreign pathogens, upon which they release cytokines in response to infection. Myeloid dendritic cells are responsible for capturing, processing and presenting antigens on their surface to T cells (Chistiakov et al. 2015; Chistiakov et al. 2014).

### 1.1.2 NK cells

Another highly important cellular component of innate immunity are the natural killer (NK) cells. These are the only lymphocytic cells belonging to the innate immune system. They do not require pre-stimulation to perform their effector functions. Unlike T or B lymphocytes, NK cells do not rearrange T-cell receptor or immunoglobulin genes from their germline configuration. They originate in the bone marrow, under the influence of interleukin 2 (IL-2) and interleukin 15 (IL-15), as well as other bone marrow cells. Although they are classified as lymphocytes, these cells do not have receptors for specific antigens (Chaplin 2010).

NK cells can be classified into two subsets, depending on their immunophenotype and function: CD56<sup>Dim</sup> and CD56<sup>Bright</sup>. CD56<sup>Dim</sup> constitutes 90% of the total NK cell population in peripheral blood. Functionally, this population is highly cytotoxic. Approximately 10% of NK cells belong to the CD56<sup>Bright</sup> subset and they are mostly involved in the production of cytokines (Mandal & Viswanathan 2011).

NK cells can be described as cytolytic effector lymphocytes, which, unlike cytotoxic T cells, can directly induce the death of tumor cells and virus-infected cells in the absence of specific immunization (hence their name). NK cells have been recognized as major producers of cytokines such as interferon- $\gamma$  (IFN- $\gamma$ ) in many physiological and pathological conditions. NK cells also have the ability to produce an array of other cytokines, both pro-inflammatory (tumor necrosis factor  $\alpha$  (TNF- $\alpha$ )) and immunosuppressive (IL-10) chemokines, and growth factors (Figure 2) (Vivier et al. 2011).

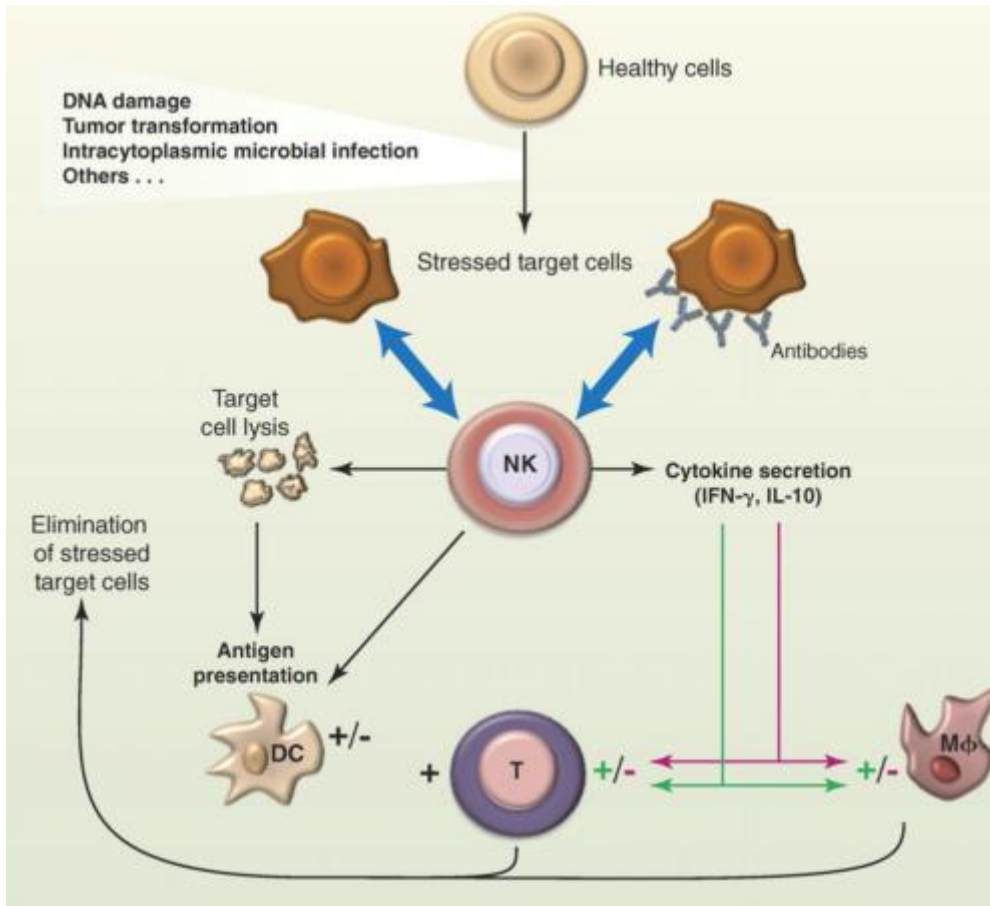

**Figure 2. Mechanism of action of NK cells.**

Upon recognizing stressed cells, NK cells are activated, resulting in the lysis of the target cell and in the production of various cytokines and chemokines, depending on the nature of the stimulation (Vivier et al. 2011).

NK cells have an array of inhibitory and activating receptors that engage major histocompatibility complex (MHC) class I molecules, MHC class I-like molecules, and molecules unrelated to MHC. As a result, NK cells are restricted in what target cells they can engage by the expression of the target's MHC ligands (Moretta et al. 2004).

NK cells effector functions are controlled by a wide range of cell surface receptors, inhibitory or activating functions. The inhibitory receptors consist of the killer immunoglobulin-like receptors (KIR) or immunoglobulin-like receptors, the C type lectin receptors (CD94-NKG2A) and leukocyte inhibitory receptors (LIR1, LAIR-1). Activating receptors are the natural cytotoxicity receptors (NKp46, NKp44), C type lectin receptors (NKG2D, CD94-NKG2C), and Ig-like receptors (2B4) (Figure 3). Due

to the fact that individual NK cells express different combinations of inhibitory or activating receptors, there is a great heterogeneity amongst the NK cell population. Thus, NK cells are considered to have the ability to respond to a variety of stimuli and to participate in immune responses under different pathological conditions (Golden-Mason & Rosen 2013).

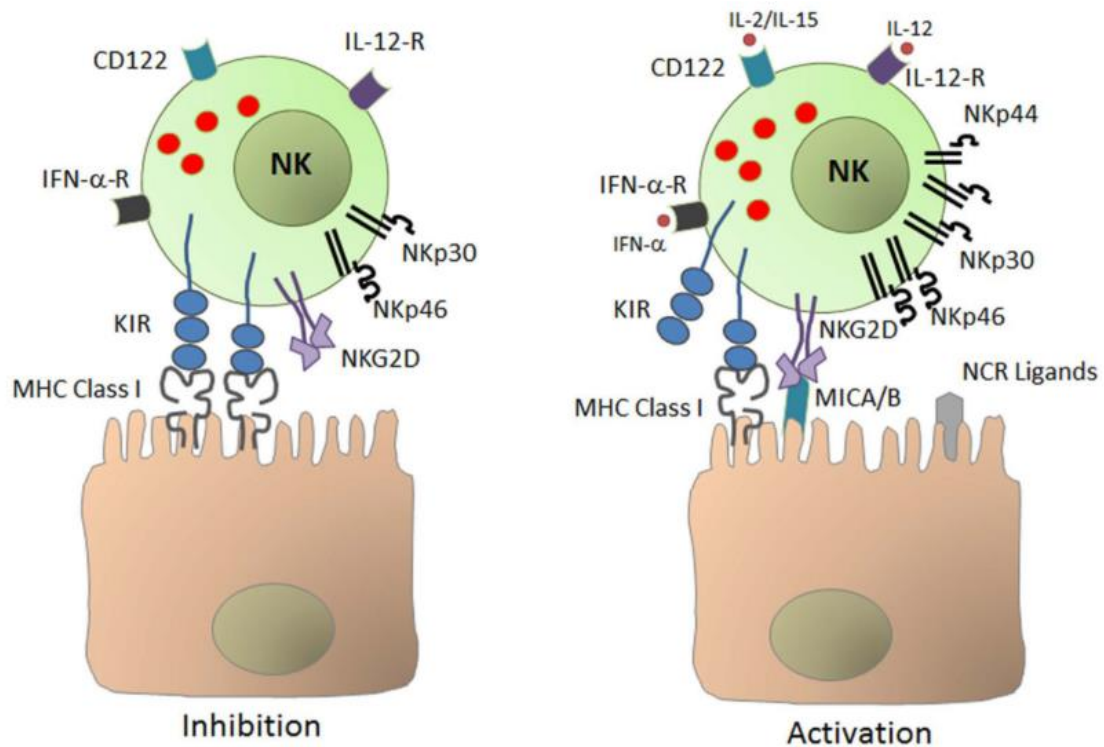

**Figure 3. Illustration of the various NK cells receptors.**

NK cells effector functions are controlled by a wide range of cell surface receptors. These receptors are either inhibitory (KIR, CD94/NKG2A) or activating (CD94/NKG2C, NKp46, NKp44) (Golden-Mason & Rosen 2013).

NK cell cytotoxicity is tightly regulated by a balance between signals from these activating and inhibitory receptors. The inhibitory NK cell receptors recognize self-MHC class I molecule, preventing NK cell activation, resulting in self-tolerance and prevention of host cell killing. NK cells are activated when they encounter cells which lack self-MHC class I molecule, known as the ‘missing-self’ hypothesis. Moreover, NK cells can distinguish between normal host cells and infected or abnormal

cells by recognition of MHC class I molecules. Infected cells and tumor cells usually downregulate MHC class I expression, in order to avoid being recognized by cytotoxic T lymphocytes, leading to a greater vulnerability to NK cell attacks (Mandal & Viswanathan 2011).

## **1.2 Adaptive immunity**

The main characteristic of adaptive immunity is the use of antigen-specific receptors (present on T and B cells) to provide effector capabilities. First, a specific antigen as to be presented to and be recognized by the antigen specific T or B cell, leading to cell priming, activation, and differentiation, usually occurring within the specialized environment of lymphoid tissue. Secondly, the effector response takes place, either due to the activated T cells leaving the lymphoid tissue and homing to the disease site, or due to the release of antibody from activated B cells (plasma cells) into blood and tissue fluids, and thence to the infective focus (Parkin & Cohen 2001).

Another key feature of the adaptive response is the production of cells that persist for a long time in an apparently dormant state, but that can re-express effector functions rapidly after another encounter with their specific antigen. This enables the immune system to develop the ability to present immune memory, enabling a more effective host response against specific pathogens or toxins when they are encountered a second time, even decades after the initial sensitizing encounter (Chaplin 2010).

B and T cells are part of the adaptive immune response, and express an almost unlimited set of recombinant Ig receptors and T-cell receptors (TCR), respectively, which are able to recognize any antigen and once activated retain a specific long-term memory (Cooper & Alder 2006).

### **1.2.1 T cells**

Most T cells are defined by the expression of surface  $\alpha\beta$ TCR. This receptor's main function is to recognize peptide antigens presented in a complex with class I or

class II MHC proteins. Most  $\alpha\beta$  T cells differentiate into two different subsets:  $CD8^+$  T cells primary role is to kill cells infected with intracellular microbes;  $CD4^+$  T cells mainly regulate the cellular and humoral immune responses.

While in the thymus, most developing T cells follow a differentiation pathway in which they first express neither CD4 nor CD8 (double negative, DN) and then express both CD4 and CD8 (double positive, DP). Double-positive cells undergo a positive selection in the cortex. Those that have more affinity to class I MHC molecules become  $CD4^+CD8^+$ , while those that are selected on class II MHC molecules become  $CD4^+CD8^-$ . Cells that survive positive selection then move to the medulla for negative selection and are exported to the periphery. In the blood and secondary lymphoid organs, 60% to 70% of T cells are  $CD4^+CD8^-$  ( $CD4^+$ ) and 30% to 40% are  $CD4^+CD8^+$  ( $CD8^+$ ) (Figure 4) (Germain 2002).

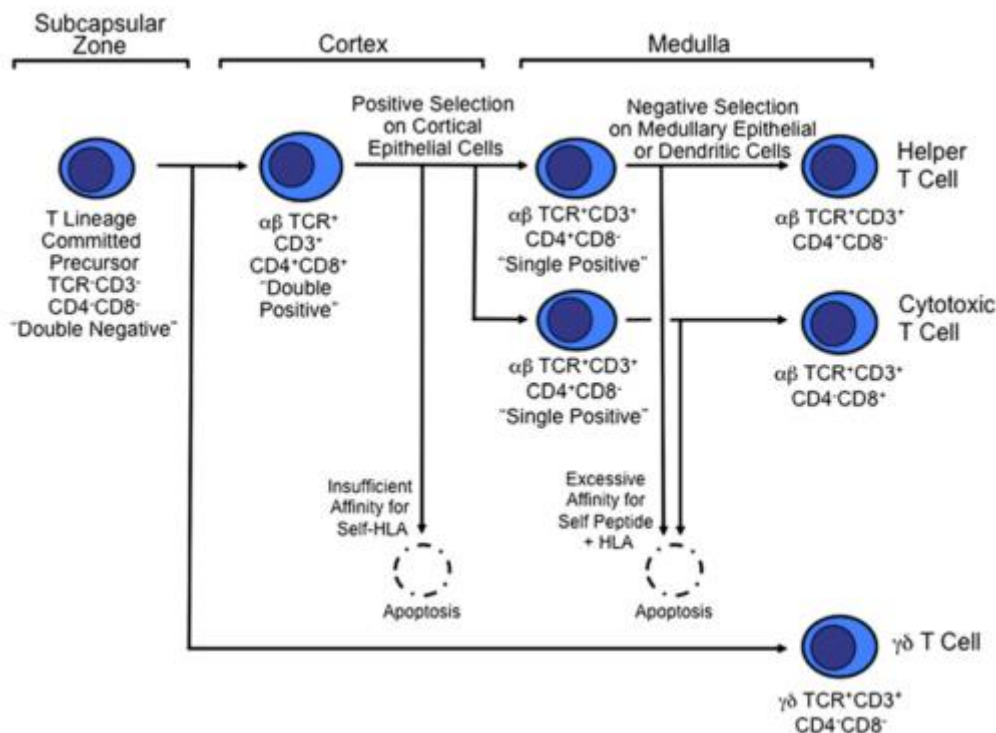

**Figure 4. Differentiation and maturation of T cells in the thymus.**

Hematopoietic stem cells, which do not express CD3, CD4, or CD8 but are committed to T-cell differentiation, move from the bone marrow to the thymus, where the surface expression of the CD3, CD4, and CD8 proteins is induced. These  $CD4^+CD8^+$  (double-positive, DP) cells undergo a positive selection for their ability to recognize self class I or class II HLA proteins, leading to the expression of either CD8 or CD4, respectively. Selected CD4 or CD8 single-positive cells

## Introduction

then undergo negative selection to remove cells with excessive affinity for self-antigens presented in HLA molecules. Single positive cells then migrate to the periphery (Chaplin 2010).

T CD8 cells show great cytotoxic activity against microbe infected cells, as well as against tumor cells (Chaplin 2010).

Since infections may be persistent, have a latent phase, or become secondary infection after the resolution of primary infections, responding T CD8 cells must have at least two sub-types: a replicative cell type capable of self-renewal and continual clonal expansion; and cytotoxic cells with effector functions that immediately act and resolve the infection in the peripheral tissues. In order to present memory, the response must also generate replicating T cells that persist in the absence of antigen after the primary infection is cleared (Bannard et al. 2009).

In the presence of an infection or in response to vaccination, *naïve* antigen-specific T CD8 cells undergo an activation process, whereby an initial encounter with an appropriately activated antigen-presenting cell leads to an exponential increase in the numbers of antigen-specific T CD8 cells. This, in turn, leads to a dynamic differentiation process, resulting in formation of both primary effector and long-lived memory cells (Obar & Lefrançois 2011).

The activation of T CD8 cells primarily depends on three signals: antigenic stimulation through the TCR; co-stimulation through costimulatory molecules; and stimulation through receptors for inflammatory cytokines. *Naïve* antigen-specific T CD8 cells receiving these signals will undergo expansion, generating a great number of effector T CD8 cells. In addition, activation then results in the acquisition, by the responding cells, of several effector functions, such as the expression of cytokines (IFN- $\gamma$  and TNF- $\alpha$ ) and perforin and granzyme molecules, necessary for cytolytic activity. Furthermore, at this point, the armed effector T cells will migrate to virtually any tissue in the body with the intent of removing all infected cells (Obar & Lefrançois 2011; Kaech et al. 2002).

The remaining pathogen-specific T cells form the memory T cell population. These memory T CD8 cells will then persist long term in the host in an antigen-



independent and TCR-independent but cytokine-dependent manner. T CD8 memory cells are able to rapidly respond to an infection. These cells persist in relatively large numbers, compared to *naïve* T cells, in multiple tissues of the body, which positions them on the front line to respond to a pathogen in several organs. Secondly, memory T cells are able to rapidly re-express effector molecules, such as cytokines. The ability to rapidly respond is a result of, at least in part, the hyper-responsive state of memory T cells compared to *naïve* T cells. T CD8 memory cells are divided based on homing potential and other effector functions, as well as cytokine profiles. Central memory T cells are mostly present in the lymphoid organs and have a superior expansion potential. Effector memory T cells develop faster effector functions and have greater migratory properties that allows them to circulate through extra-lymphoid tissues (den Haan et al. 2014).

T CD4 cells display delayed hypersensitivity responses, activating both humoral immune responses and cellular responses. Similarly to T CD8 cells, T CD4 cells also differentiate into functionally distinct subsets after exposure to antigen. *Naïve* T CD4 cells can differentiate into memory or effector populations. Resting *naïve* T CD4 cells, designated T helper (Th) cells, release very low levels of cytokines. These cells, after stimulation by antigen and antigen-presenting cells (APCs), begin to produce IL-2, being designated as Th0. As activating signal continues to affect Th cells, these may differentiate into distinct cell populations, designated Th1, Th2 and Th17, depending on the cytokines present at the tissue of activation. IL-12 induces differentiation toward Th1; IL-4 toward Th2; and transforming growth factor  $\beta$  (TGF- $\beta$ ) and IL-6 toward Th17. Th cells are generally characterized by the expression of different cytokines: Th1 express IL-2, IFN- $\gamma$ , and lymphotoxin, Th2 cells produce IL-4, IL-5, IL-9, IL-13, while Th17 cells produce cytokines IL-6 and IL-17 (Hatton 2011; Paul 2010; Ma et al. 2012).

Th1 and Th2 cells usually participate together in immune responses. However, after prolonged immunization, the immune response can lean towards becoming dominantly Th1 or Th2 like. Generally, Th1 cells' role is to support cell-mediated immunity, while Th2 cells' is to support humoral and allergic responses. Th17 cells are involved in the early response to extracellular bacteria and parasites, and help to recruit the neutrophil response that eliminates these pathogens. They are also involved in the inflammatory responses in many autoimmune diseases (Chaplin 2010).

## Introduction

Another population of circulating CD4<sup>+</sup> T cells plays an important regulatory role that acts to down modulate immune responses. These cells, designated regulatory T (Treg) cells, are divided into two main groups. The first group of Treg cells secretes immunomodulatory cytokines TGF- $\beta$  and IL-10. These are called natural Treg cells, and are characterized by surface expression of the CD4 and CD25 antigens and by nuclear expression of the forkhead box protein 3 (Foxp3) transcription factor. The second group of Treg cells differentiates in the periphery from *naïve* CD4<sup>+</sup>T cells. Because they develop in response to stimulation with specific antigen, they are called adaptive or induced Treg cells (Chaplin 2010).

### 1.2.2 $\gamma\delta$ T cells

Approximately 5% to 10% of T cells in the peripheral blood, lymph nodes, and spleen are CD4-CD8-. Most of these cells use  $\gamma\delta$  TCRs. Unlike  $\alpha\beta$  T cells,  $\gamma\delta$  T cells do not require the help of MHC class I and class II molecules for recognizing the antigens. Antigen recognition by  $\gamma\delta$  T cells is dependent upon the particular variable region of the T cell receptor (TCR) as opposed to the entire rearranged TCR required by  $\alpha\beta$  T cells (Gogoi & Chiplunkar 2013).

$\gamma\delta$  T cells can perform complex functions, such as immune surveillance, immunoregulation, and effector function, without undergoing clonal expansion. Heterogeneous distribution and anatomic localization of  $\gamma\delta$  T cells in the normal and inflamed tissues play an important role in the immune response (Paul et al. 2014).

$\gamma\delta$  T cells express various activation and inhibitory molecules, such as NKG2D and CD94/NKG2A, and secrete several cytokines, like TNF- $\alpha$  and IFN- $\gamma$ , that play an important role in the pathogenesis of various diseases. Several of these signaling molecules dictate the outcome of  $\gamma\delta$  T cell effector function. Apart from secreting cytokines,  $\gamma\delta$  T cells can also secrete chemokines, which influence recruitment of other immune cells at the site of inflammation and modulate the function of other innate and adaptive immune cells. By expressing NK cell associated receptors,  $\gamma\delta$  T cells have the advantage of recognizing cells that express stress induced molecules receptors (Gogoi & Chiplunkar 2013; Paul et al. 2014; Bacchetta et al. 2007).

### 1.2.3 B Cells

B cells encompass approximately 15% of peripheral blood leukocytes. They are characterized by their production of immunoglobulin. Differentiation of stem cells to the B lineage occurs in the bone marrow and depends on bone marrow stromal cells that produce IL-7. Immature self-reactive B cells are subjected to negative selection through deletion, receptor editing and anergy to ensure that the emerging B cells have no functional self-reactive. Immature B cells then migrate to the periphery, where they differentiate into transitional B cells, and start expressing IgM and IgD. Transitional B cells mark the crucial link between bone marrow immature and peripheral mature *naïve* B cells. Finally, mature *naïve* B cells can differentiate into memory B cells or plasmablastic B cells (Carsetti 2000).

*Naïve* B cells express IgM and IgD on their cell surfaces. As B cells mature under the influence of Th cells, T cell-derived cytokines induce isotype switching. Isotype switching is a process of DNA rearrangement where the VhDhJh exon is rearranged into a position immediately upstream of alternative heavy chain exons. This permits a functionally rearranged VhDhJh exon to be used to produce antibodies of different isotypes but the same antigenic specificity. Depending on the cytokine, the antibodies can be IgA, IgG1, IgG2, IgG3 or IgE. At the same time as B cells undergo isotype switching, another process, designated somatic mutation, produces mutations, apparently randomly, in the antigen-binding portions of the heavy and light chains. If these mutations result in loss of affinity for the antigen, the cell loses important receptor-mediated growth signals and dies. However, if the mutations result in increased affinity for the antigen, then the cell producing that antibody has a proliferative advantage in response to antigen and grows to dominate the pool of responding cells (Chung et al. 2003; Bende et al. 2009; den Haan et al. 2014; Chaplin 2010).

### **1.3 Invariant natural killer T cells**

Invariant natural killer T (iNKT) cells are a specialized subset of T cells that use their T cell receptors (TCRs) to recognize self and foreign lipids presented by CD1d as cognate antigens. These cells bridge innate and adaptive immunity and modulate immune responses in autoimmunity, malignancies and infections. iNKT cells exert their function by both direct cytotoxicity and cytokine production, activating other immune cells.

Although initially identified by co-expression of conventional  $\alpha\beta$  TCRs and markers typically associated with NK cells, NKT are currently distinguished on the basis of CD1d restriction as well as specific usage of TCR $\alpha$  chains.

iNKT cells exist in a 'poised effector' state, are able to respond in an innate-like manner to danger signals and pro-inflammatory cytokines, and present their effector functions within hours of being activated, all of which are innate characteristics. Furthermore, iNKT cells share extensive transcriptional identity with both innate and adaptive immune cells.

iNKT cells may be activated by two distinct pathways: a TCR signal, provided by a lipid-CD1d complex. This pathway has very little dependence on cytokines produced by APCs; and a cytokine signal that depends on the constitutive expression of certain cytokine receptors by iNKT cells. In this case, APC-derived cytokines are generated in response to the stimulation of pattern-recognition receptors. However weak, a TCR signal is still necessary in this pathway. (Brennan et al. 2013; Peukert et al. 2014; Pilonis et al. 2014)

### **1.4 Complement**

The complement system is a very important effector component of the immune system. The complement system is composed of more than 25 plasma and cell-surface proteins that include 3 activation pathways and soluble and membrane-bound regulatory pathways.

Initially, the complement system was thought to play a major role in innate immunity, where a robust and rapid response is initiated against invading pathogens.

However, it has become increasingly evident that the complement also plays an important role in adaptive immunity, by helping T and B cells eliminating pathogens and in preventing pathogenic re-invasion. Moreover, it is also involved in tissue regeneration, tumor growth and human pathological states.

Three pathways lead to activation of complement. The classical pathway is initiated by complexes of IgM, IgG1, or IgG3 with antigens. The lectin pathway is activated when mannose binding lectin binds to carbohydrate moieties on surfaces of pathogens including yeast, bacteria, parasites and viruses. The alternative pathway is initiated by interactions between microbial antigens and inhibitory complement regulatory proteins. These pathways all cleave a protein designated C3 to generate the C3a fragment and depositing C3b on the activating microbial particle or immune complex. Together, these 3 activation pathways allow the complement to take part in the destruction and clearance of a wide variety of pathogens and macromolecules (Figure 5).

The effector functions of the complement include the formation of pores in cell membranes, promoting lysis, cellular tissue damage, and vasodilation, as well as cytokine and chemokine release. The complement also promotes neutrophil and macrophage attraction, as well as contributing to T cell and antigen-presenting cell activation, expansion, and survival (Chaplin 2010; Ricklin 2011; Sarma & Ward 2012; Mathern & Heeger 2015).

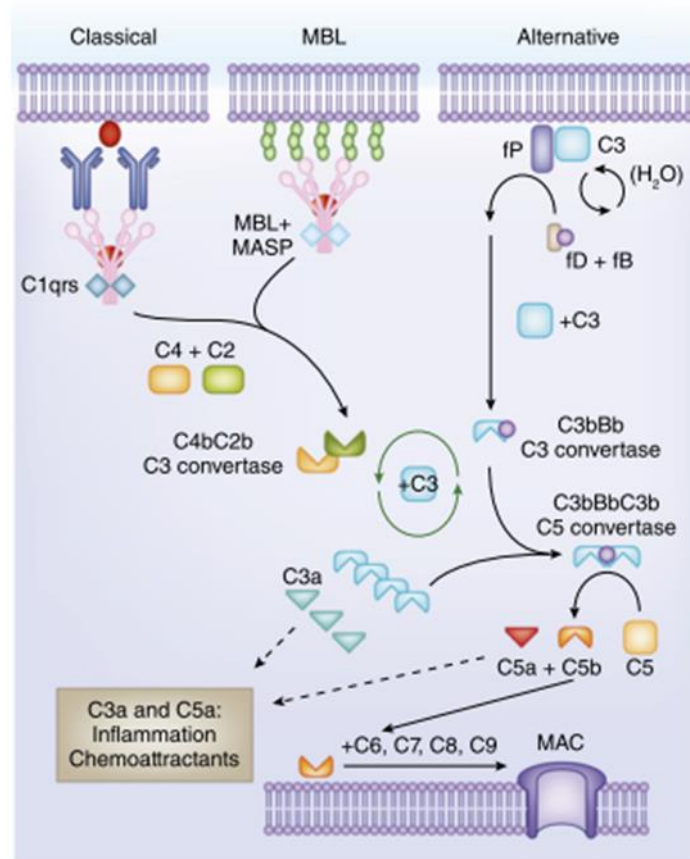

**Figure 5. Overview of the complement cascade.**

The three activation pathways of complement: the classical pathway, the lectin pathway and the alternative pathway. (Mathern & Heeger 2015)

## 2 Immunology of patients with kidney disease

Loss of renal function is strongly associated with a pro-inflammatory background and an impaired immune system. This impairment may lead to an uremia-associated defect in the immune system, which has a broad clinical impact in terms of mortality in patients with impaired kidney functions. These patients have an increased risk of infections, have a poor response to standard vaccination, and have a higher susceptibility to virus-associated cancers. The pro-inflammatory status of these patients is most likely caused by increased oxidative stress and immune cell activation, two highly connected phenomena. Pro-inflammatory cytokines might generate oxidative stress, whereas an inflammatory immune response might be generated by oxidative stress. Retention of toxins and cytokines, resulting from the higher amounts of circulating uremia, may lead to the generation of oxidative stress and inflammation. Molecular pattern recognition receptors are expressed on both immune and non-immune cells, and are generally involved in the immune response to pathogens and tissue damage. These can mediate cell activation in response to products of increased oxidative stress, that is, reactive oxygen species (ROS). Moreover, oxidized low-density lipoprotein (LDL) may also lead to immune system dysfunction by interacting with the T cell receptor and by stimulating activation-induced T-cell apoptosis. Uremia-induced activation of T cells leads to upregulation of cytokine receptors (such as IL-2 and TNF- $\alpha$  receptors) and to a resulting decreased responsiveness of the activated cells to exogenous IL-2 or TNF- $\alpha$  (Betjes 2013; Cohen & Hörl 2012).

Both the innate and adaptive cellular immune systems are affected by kidney disease. For instance, phagocytic cells, like neutrophils, progressively increase as renal function declines, leading to an over-expression of receptors like TLR2 and TLR4. This causes an increased basal activation state, leading to a greater production of ROS and degranulation after stimulation. These conditions might be caused by increased concentrations of pro-inflammatory cytokines, such as TNF- $\alpha$ , or by advanced oxidation protein products resulting from increased oxidative stress. Despite being increasingly activated, phagocytic cells show impaired migratory and phagocytic capabilities. Moreover, studies have shown that the absolute number of NK cells in kidney impaired patients is markedly decreased. However, the expression of activation markers, such as CD69 and NKp44, was markedly increased, while the expression of the activating

receptor NKG2D was decreased. The reduced number of NK cells and their possible decreased function might contribute to reduced tumor immune surveillance and increased susceptibility to viral infections, as a result of decreased killing of infected cells and reduced potentiation of adaptive immune responses (Vacher-Coponat et al. 2008; Peraldi et al. 2009).

Monocytes from patients with uremia also present a more activated state, with increased expression of integrin and TLRs, and increased secretion of pro-inflammatory cytokines. On the other hand, their phagocytic function is decreased. Typically, the number of circulating pro-inflammatory monocytes is also increased, compared with healthy controls, leading to higher amounts of TNF- $\alpha$ , IL-6 and IFN- $\gamma$  (Betjes 2013).

Regarding the adaptive immune system cells, severe renal impairment is associated with a decrease in the total number of T cells, both CD4 and the T CD8 cell, which can largely be attributed to a decline in *naïve* T cell numbers. However, these patients have more proliferating *naïve* T cells than healthy controls and both *naïve* and memory T cells from patients with uremia show an increased susceptibility to activation-induced apoptosis. These patients also have a reduced number of circulating Treg cells, and those circulating are dysfunctional (Hauser et al. 2008).

Similarly to T cells, kidney impairment is associated with a gradual decline in circulating numbers of B cells, more significantly in the *naïve* B cell population. Their *in vivo* spontaneous apoptosis was also increased (Betjes 2013).

Progressive loss of renal function is associated with a pro-inflammatory status and functional defects in almost all innate and adaptive immune cell populations. The effects of increased immune cell activation and diminished immune cell function might explain the increased susceptibility of patients with renal impairment to viral and bacterial infections and their increased risk of malignancies (Figure 6)(Betjes 2013; Kato et al. 2008; Kurts et al. 2013).



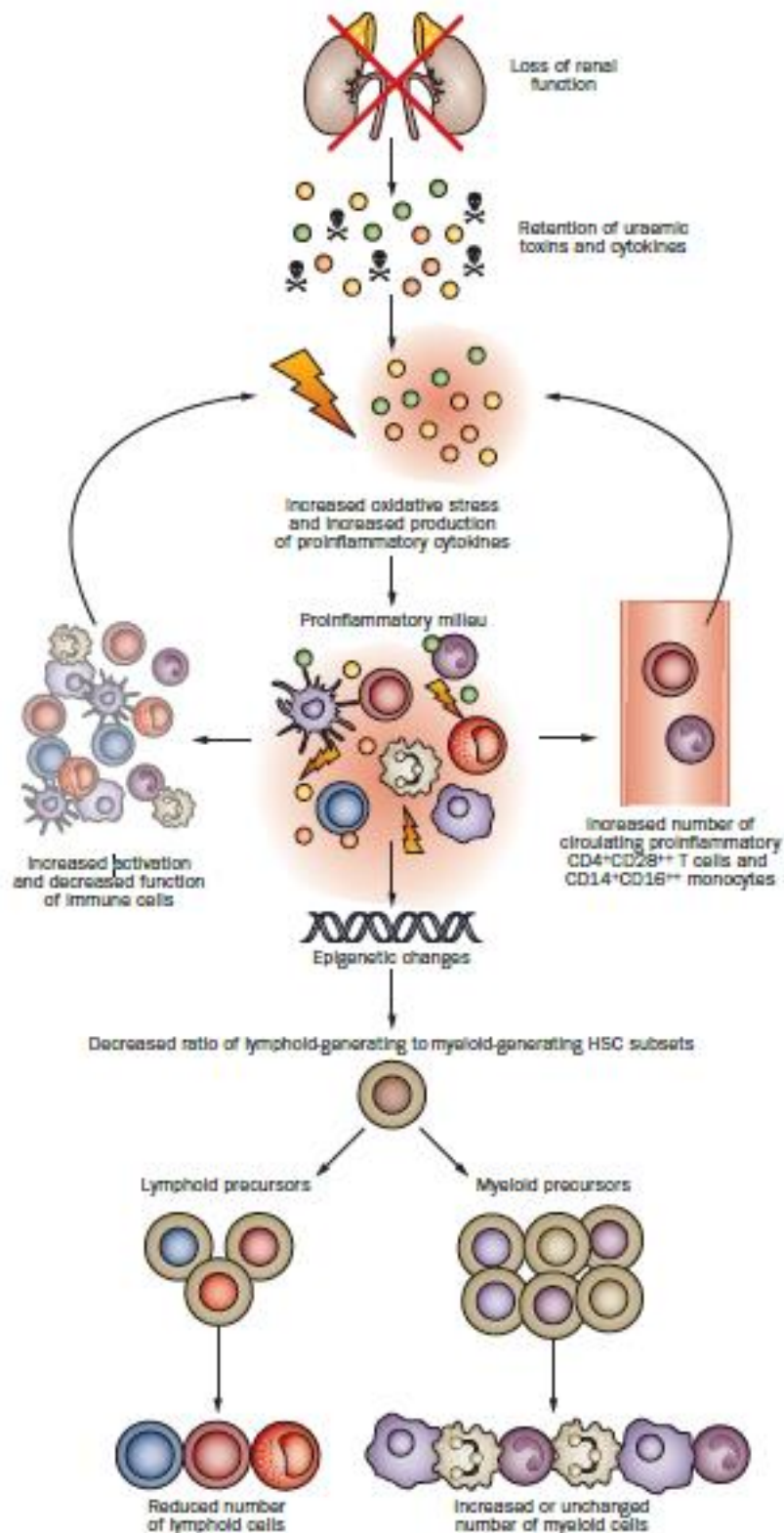

**Figure 6. Immunological alterations resulting of the loss of renal function.**

Loss of renal function causes retention of uremic toxins and cytokines, leading to inflammation and increased oxidative stress (Betjes 2013).

### 3 Renal replacement therapies: Hemodialysis and Peritoneal Dialysis

Peritoneal dialysis is a process by which a dialysis solution is injected into the peritoneal cavity using a percutaneous abdominal catheter. Water and solutes are exchanged between the capillary blood and the intraperitoneal dialysate across the peritoneum.

Conventional peritoneal dialysis fluids consist of an aqueous solution of electrolytes similar to the plasma, a bicarbonate precursor (usually lactate), and glucose as an osmotic agent, along with dextrose, to produce fluids of different osmolality (Figure 7) (Saxena 2005; Saxena & West 2006).

Hemodialysis is a process used in patients with renal impairment to remove waste products from the blood. The patients are connected to a hemodialysis machine, where the blood and dialysate flow across the dialyzer membrane, without concentration equilibration, effectively removing small solutes (Misra 2008).

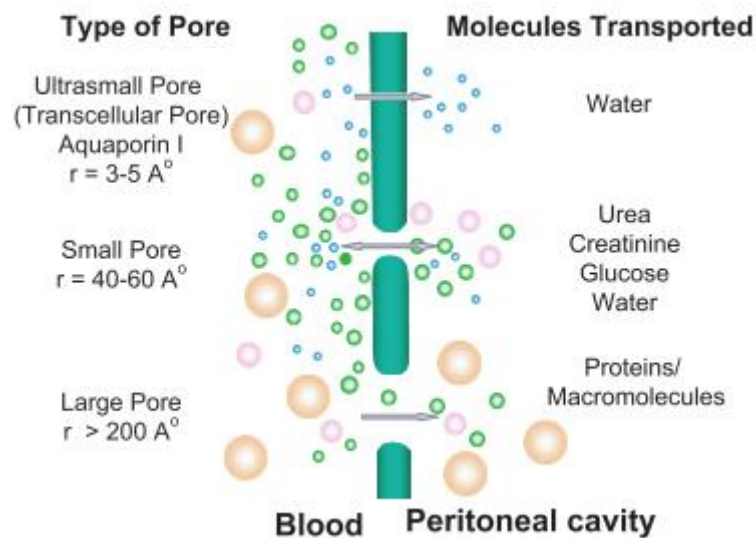

**Figure 7. Three-pore model of the peritoneal membrane.**

---

Peritoneal dialysate flows across the membrane, filtrating different solutes depending on the size of the pores(Saxena & West 2006)

### **III Objectives**



Due to their condition, patients under peritoneal dialysis and hemodialysis therapies have a debilitated immune system, and as a result are more susceptible to infection. In addition, inflammatory state can also be potentiated by these therapies, due to their invasive nature.

In order to study which of these therapies has a greater influence on the immune system, the objective of the present study was to perform a thorough immunological characterization of patients undergoing hemodialysis and peritoneal dialysis.

Using a fluorescence-based technique (flow cytometry), several leukocyte populations, such as B cells, T cells, Monocytes, Dendritic cells, iNKT cells,  $\gamma\delta$  T cells and NK cells, their subpopulations and surface molecules were quantified using different fluorescent antibody conjugates. The obtained results were then compared with the same parameters obtained from a healthy control group.



## **IV Materials and Methods**





## **1 Study populations and samples**

A group of 21 peripheral blood samples from patients undergoing peritoneal dialysis, 11 from patients undergoing hemodialysis and 12 from healthy patients were collected in both EDTA tubes (for apoptosis detection) and Heparin tubes (for flow cytometry staining). These act as anticoagulants, preventing the samples from clotting.

The samples from the healthy controls and the patients undergoing peritoneal dialysis were collected at Centro Hospitalar e Universitário de Coimbra, while the samples from patients undergoing hemodialysis were collected at Casa de Saúde de Santa Filomena.

Blood donors and patients signed informed consent and this study was previously approved by the Ethics Committee of Faculdade de Medicina da Universidade de Coimbra and Centro Hospitalar e Universitário de Coimbra.

## **2 Cell Counting**

Whole Blood cells were counted using a COULTER AC•T diff Analyzer (Beckman Coulter, Pasadena, Califórnia, EUA). The COULTER AC•T diff Analyzer uses 12  $\mu$ L of the sample to accurately count blood cells populations by measuring changes in the electrical resistance when the cells pass through a small channel.

## **3 Surface and Intracellular staining for Flow Cytometry**

### **3.1 Surface staining**

After counting,  $10^6$  cells were transferred to a 5 mL cytometry tube. Recommended volumes of monoclonal antibodies were added to the samples, and these were incubated in the dark for fifteen minutes, at room temperature. Then, 2 mL of BD Lysing Solution® were added to the samples, which were once again incubated

in the dark for ten minutes, at room temperature. The samples were centrifuged at 300 g for 5 minutes and the supernatant was wasted. The pellet was washed with 2 mL of PBS 1x and centrifuged at 300 g for 5 minutes. The supernatant was discarded and the pellet resuspended in 300  $\mu$ L of PBS 1x and analyzed by flow cytometry.

### **3.2 Intracellular staining**

After counting,  $10^6$  cells were transferred to a 5 mL cytometry tube. Recommended volumes of surface monoclonal antibodies were added to the samples, and these were incubated in the dark for fifteen minutes, at room temperature. 100  $\mu$ L of Fix and Perm Medium A<sup>®</sup> were then added to the samples, which were incubated for another 10 minutes in the dark, at room temperature. The cells were then rinsed with 2 mL of PBS 1x and centrifuged at 300g for 5 minutes. The supernatant was discarded and 100  $\mu$ L of Fix and Perm Medium B<sup>®</sup> were added to the pellet, along with recommended volumes of intracellular monoclonal antibodies. The samples were then incubated for 20 minutes, after which they were centrifuged at 300g for 5 minutes. The pellet was then re-suspended in 300  $\mu$ L of PBS 1x and analyzed by flow cytometry.

## **4 Leukocytes isolation and Apoptosis Detection**

Approximately 3mL of whole blood sample were diluted with PBS 1x to the volume of 5 mL. The samples were then carefully transferred to a tube with 3 mL of Ficoll-Paque<sup>®</sup> solution, without mixing the phases. The samples were centrifuged at 400g for 20 minutes, without brake. Afterwards, the leukocyte ring was transferred to a different tube, and rinsed twice with chilled PBS 1x. The pellet was re-suspended in Annexin V Binding Buffer<sup>®</sup> at a concentration of 1 million cells per mL. 100  $\mu$ L of the cell suspension were transferred to a cytometry tube, and recommended volumes of Annexin V and PI were added. The samples were incubated in the dark for 15 minutes, after which 400  $\mu$ L of Annexin V Binding Buffer<sup>®</sup> were added. The samples were immediately analyzed by flow cytometry.

## 5 Flow Cytometry and Analysis

All samples were acquired in a FACSCanto II (BD Biosciences, San Jose, CA, USA) with FACS Diva software version 6.1.3.

Data from the FACSCanto II was analyzed using FlowJo 10.0.7 (Tree Star Inc, Ashland, USA).

## 6 Statistical analysis

Statistical analyses were performed using GraphPad Prism version 6 software. Mann-Whitney non-parametric test, One-way ANOVA test were used. Statistically significant P values are annotated as follows: \*  $p < 0.05$ , \*\*  $p < 0.01$  and \*\*\*  $p < 0.001$ .

## 7 Compounds

The following compounds were used: PBS 10x, (GIBCO, Invitrogen, Carlsbad, CA, USA); BD Lysing Solution® (BD FACSTM, San Jose, CA, USA); Ficoll-Paque® solution (GE Healthcare Bio-Sciences, Uppsala, Sweden); Annexin V Binding Buffer® (BioLegend Inc, San Diego, CA, USA); Fix and Perm Medium A®, Fix and Perm Medium B® Invitrogen Corporation, Camarillo, CA, USA). All the utilized antibodies were acquired as shown in Table I.

**Table I.** Summary of the monoclonal antibodies reactivities, respective conjugates, their clone and distributors.

<b>Antibody conjugates:</b>	<b>Clone:</b>	<b>Distributor:</b>
<b>FitC:</b>		
TCR V $\alpha$ 24-J $\alpha$ 18 (iNKT) #342906	6B11	BioLegend
TCRgd #331208	B1.1/B1	eBioscience /BioLegend
CD27 #302806	O323	BioLegend
CD16 #561308	B73.1	BD Biosciences
CD94 #	DX22	BioLegend
CD62L #304804	DREG-56	BioLegend
IL-4 #500806	MP4-25D2	BD Biosciences
TGF- $\beta$ #349606	TW4-9E7	BD Biosciences
HLA-DR #555811	G46-6	BD Pharmingen
FoxP3 #320012	150D	BioLegend
<b>PE:</b>		
CD137L #559448	C65-485	BD Biosciences
TNF #559321	MAb11	BD Biosciences

Materials and Methods

NKG2A #FAB1059P	131411	R&D Systems
CD336/NKp44 #325108	P44-8	BioLegend
NKp80 #346706	5D12	BioLegend
CD26 #555437	M-A261	BD Biosciences
CD178/CD95L #564261	NOK1	BD Biosciences
TGF- $\beta$ #349704	TW4-6H10	BioLegend
<b>PerCP Cy5.5:</b>		
CD56 #318322	HCD56	BioLegend
CD4 #317428	OKT4	BioLegend
CD3 #300328	HIT3a	BioLegend
CD14 #301824	M5E2	BioLegend
CD19 #302230	HIB19	BioLegend
CD95 #46-0951	15A7	eBioscience
CD127 #351322	AO19D5	BioLegend
<b>PE-Cy7:</b>		
CD69 #310912	FN50	BioLegend
IFN- $\gamma$ #506518	B27	BioLegend
CD27 #560609	M-T271	BD Biosciences
CD56 #557747	B159	BD Biosciences
CD8 #344712	SK1	BioLegend
<b>APC:</b>		
CD137 #550890	4B4-1	BD Biosciences
CD62L #559772	SK11	BD Biosciences
NKp30 #325212	P30-15	BioLegend
NKG2C #FAB138A	134591	R&D Systems
CD335/NKp46 #558051	29A1.4	BD Biosciences
CD314/NKG2D #320808	1D11	BioLegend
IL-10 #501410	JES3-9D7	BioLegend
TCR V $\alpha$ 24-J $\alpha$ 18 (iNKT) #342908	6B11	BioLegend
CD284/TLR4 #312816	HTA125	eBioscience
<b>APC-H7:</b>		
CD8 #560179	SK1	BD Biosciences
CD25 #560225	M-A251	BD Biosciences
CD16 #302018	3G8	BioLegend
CD19 #560177	SJ25C1	BD Biosciences
<b>V450:</b>		
CD57 #359611	HNK-1	BioLegend
CD11b #560480	ICRF44	BD Biosciences
IFN- $\gamma$ #560371	B27	BD Biosciences
CD3 #560365	UCHT1	BD Biosciences
<b>V500:</b>		
CD3 #561416	UCHT1	BD Bioscience
CD14 #561391	M5E2	BD Biosciences
CD19 #561121	HIB19	BioLegend
CD4 #560768	RPA-T4	BD Biosciences

## **V Results**



In order to evaluate the differences in cells populations between healthy controls and patients undergoing renal replacement therapies – Peritoneal Dialysis and Hemodialysis – blood samples from individuals in each of these groups were analyzed by flow cytometry.

To do so, 21 samples from the PD group, 11 from the HD group and 12 from the control (CTRL) group were analyzed by Flow Cytometry, and the relative (percentage in parent population) and absolute (percentage in lymphocytes, multiplied by total number of lymphocytes) numbers of cells in each population were calculated.

Firstly, lymphocytes and monocytes were gated according to their size and complexity by Side Scatter (SSC) and Forward Scatter (FSC) parameters, as seen in Figure 8. Within these populations, subpopulations were separated, according to the presence (or absence) of distinct fluorochromes conjugated with a respective monoclonal antibody.

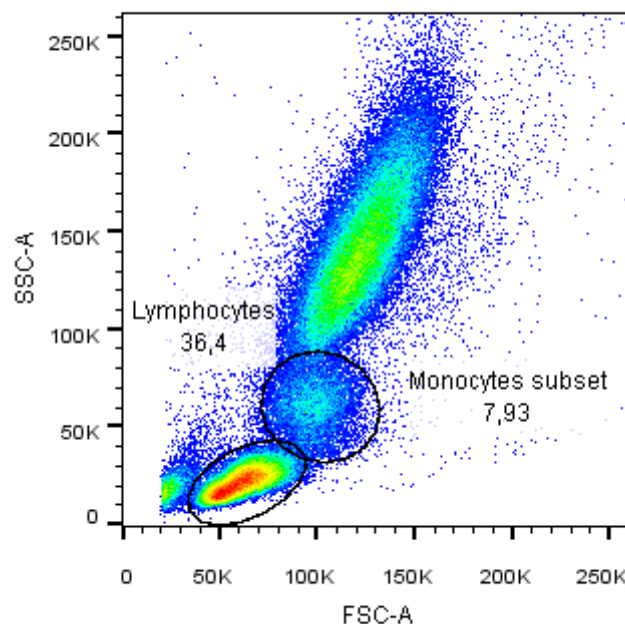

**Figure 8.** Side Scatter(SSC-A) by Forward Scatter(FSC-A) graph from Flow Cytometry, with the lymphocyte and monocyte gates.

## Results

### 1 B cells

The first subpopulation studied was that of the B cells, belonging lymphocytic cells population. B cells are characterized by the absence of CD3 and the presence of CD19. The B cells can be further divided in smaller subpopulations depending on the expression of CD27 and IgD, such as *naïve* B cells, transitional B cells, exhausted memory B cells, pre-switch memory B cells and switch memory B cells; or according to the expression of several surface molecules, like the Fas/FasL receptors. Table II presents the results of such evaluation for the B cell subpopulation.

**Table II.** B cell populations from PD, HD and CTRL groups, evaluated by flow cytometry, and their distinctive monoclonal antibodies. The groups were analyzed using One-way ANOVA test. ns: not significant; \*, \*\*, \*\*\*: statistically significant (\* p<0.05, \*\* p<0.01 and \*\*\* p<0.001).

Population	Distinctive antibodies	PD vs HD	PD vs CTRL	HD vs CTRL
<b>B cells</b>	<b>CD3<sup>-</sup> CD19<sup>+</sup></b>	ns	**	ns
<i>Naïve</i> B cells	<b>CD27<sup>+</sup> IgD<sup>+</sup></b>	ns	***	ns
<b>Transitional naïve B cells</b>	(inside <i>Naïve</i> B cells) <b>CD38<sup>+</sup> CD24<sup>+</sup></b>	ns	***	ns
<b>CD10<sup>+</sup> Transitional naïve B cells</b>	(inside Transitional <i>naïve</i> B cells) <b>CD10<sup>+</sup></b>	ns	****	***
<b>Exhausted memory B cells</b>	<b>CD27<sup>-</sup> IgD<sup>-</sup></b>	ns	ns	ns
<b>Pre-switch Memory B cells</b>	<b>CD27<sup>+</sup> IgD<sup>+</sup></b>	ns	**	ns
<b>Switch Memory B cells</b>	<b>CD27<sup>+</sup> IgD<sup>-</sup></b>	ns	*	ns
<b>Plasmablast Switch Memory B cells</b>	(inside Switch Memory B cells) <b>CD38<sup>+</sup> CD24<sup>-</sup></b>	ns	***	***
<b>CD95<sup>+</sup> CD95L<sup>-</sup></b>	---	ns	**	ns
<b>CD95<sup>-</sup> CD95L<sup>+</sup></b>	---	ns	**	ns
<b>CD95<sup>+</sup> CD95L<sup>+</sup></b>	---	ns	ns	ns
<b>CD95<sup>-</sup> CD95L<sup>-</sup></b>	---	ns	**	ns
<b>CD27<sup>+</sup></b>	---	ns	ns	ns

Figure 9 presents the comparison of B cells population in the different groups, as an absolute frequency and as percentage of lymphocytes.



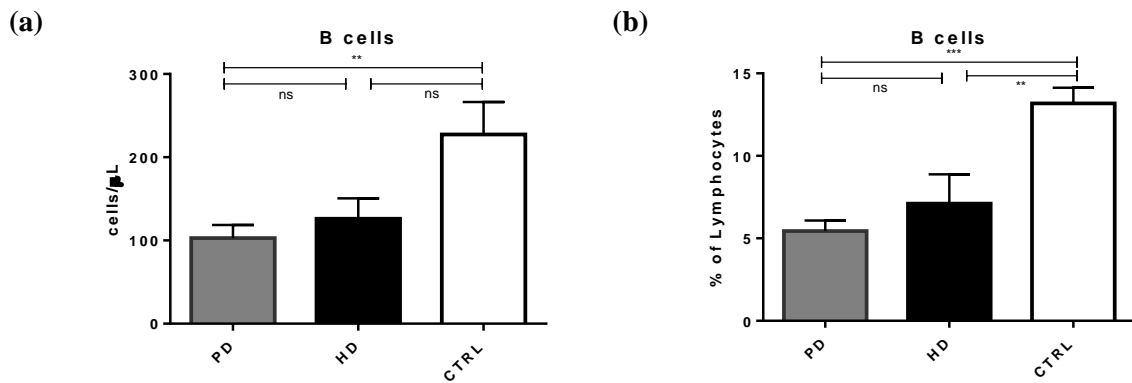

**Figure 9.** Analysis of the absolute frequency (a) and as a percentage of lymphocytes (b) of B cells in the PD, HD and CTRL groups. One-way ANOVA test was used to compare the different groups. ns: not significant; \*, \*\*, \*\*\*: statistically significant (\*  $p < 0.05$ , \*\*  $p < 0.01$  and \*\*\*  $p < 0.001$ ).

As seen in Figure 9, a statistically significant difference is seen between total B cells in the PD and the CTRL groups. Although also lower in the HD group than in the CTRL group, the difference is not statistically significant. The percentage in lymphocytes is also decreased in the PD and HD groups with a statistically significant difference to both treated groups.

### 1.1 B cell subsets

Figure 10 presents the comparison of *naïve*, *naïve* transitional and  $CD10^+$  *naïve* transitional B cells subpopulations in the different groups, as an absolute frequency and as percentage of their parent populations.

## Results

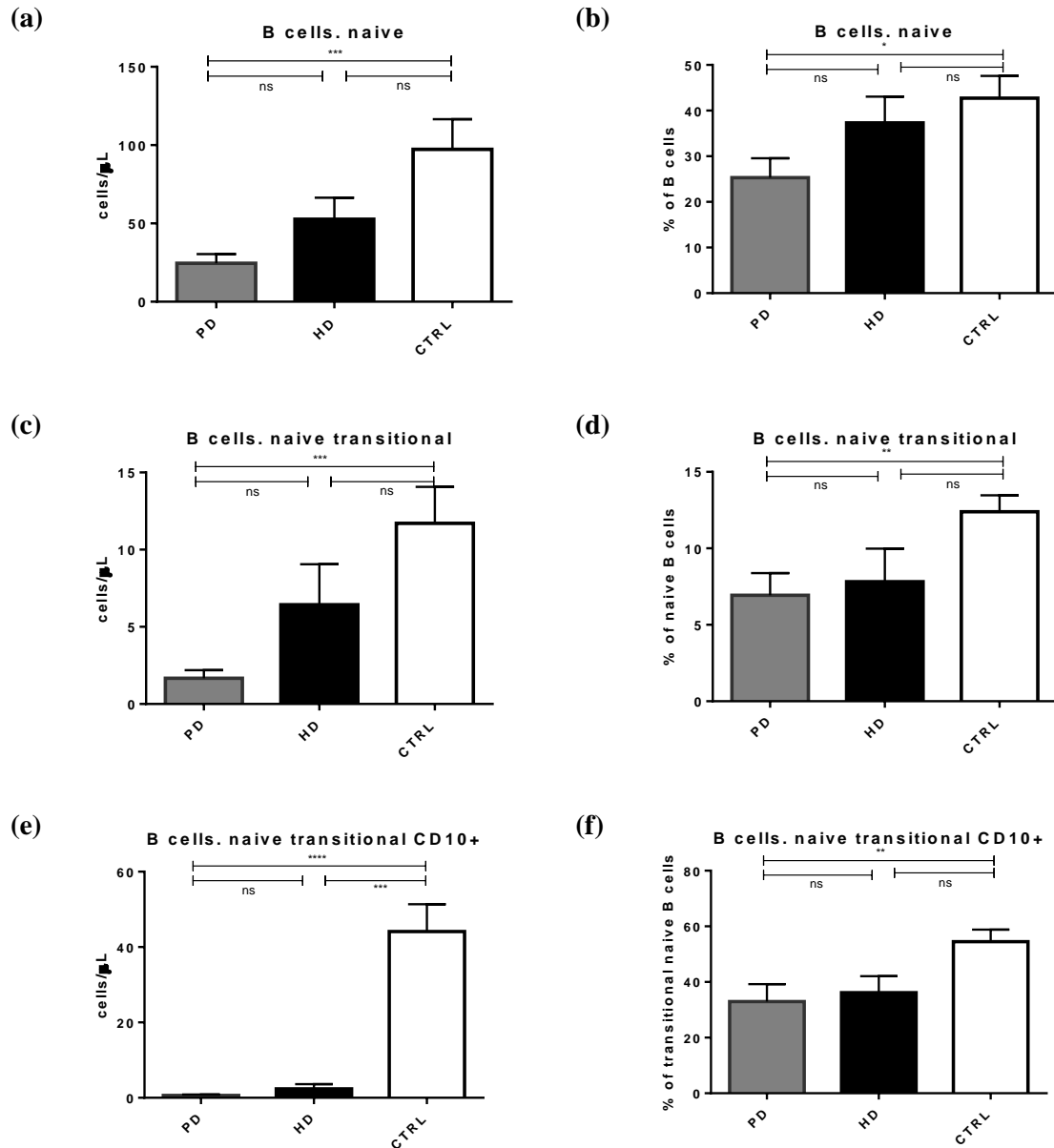

**Figure 10.** Analysis of the absolute frequency of *naïve* B cells (a), transitional *naïve* B cells (c) and CD10<sup>+</sup> transitional *naïve* B cells (e); and *naïve* B cells as a percentage of B cells (b), transitional *naïve* B cells as a percentage of *naïve* B cells (d) and CD10<sup>+</sup> transitional *naïve* B cells as a percentage of transitional *naïve* B cells (f) in the PD, HD and CTRL groups. One-way ANOVA test was used to compare the different groups. ns: not significant; \*, \*\*, \*\*\*\*: statistically significant (\* p<0.05, \*\* p<0.01 and \*\*\*\* p<0.001).

As seen in Figure 10, a statistically significant difference is seen between total *naïve*, *naïve* transitional and CD10<sup>+</sup> *naïve* transitional B cells in the PD comparatively to the CTRL group. The same applies to CD10<sup>+</sup> *naïve* transitional B cells in the HD group. Although also decreased in the HD group comparatively to the CTRL group, the

difference is not statistically significant in *naïve* and *naïve* transitional B cells. The percentage in the parent population is also decreased in *naïve*, *naïve* transitional and CD10<sup>+</sup> *naïve* transitional B cells with a statistically significant difference to between the PD and the HD group.

Figure 11 presents the comparison of pre-switch memory, switch memory and switch memory plasmablast B cells subpopulations in the different groups, as an absolute frequency and as percentage of their parent populations.

## Results

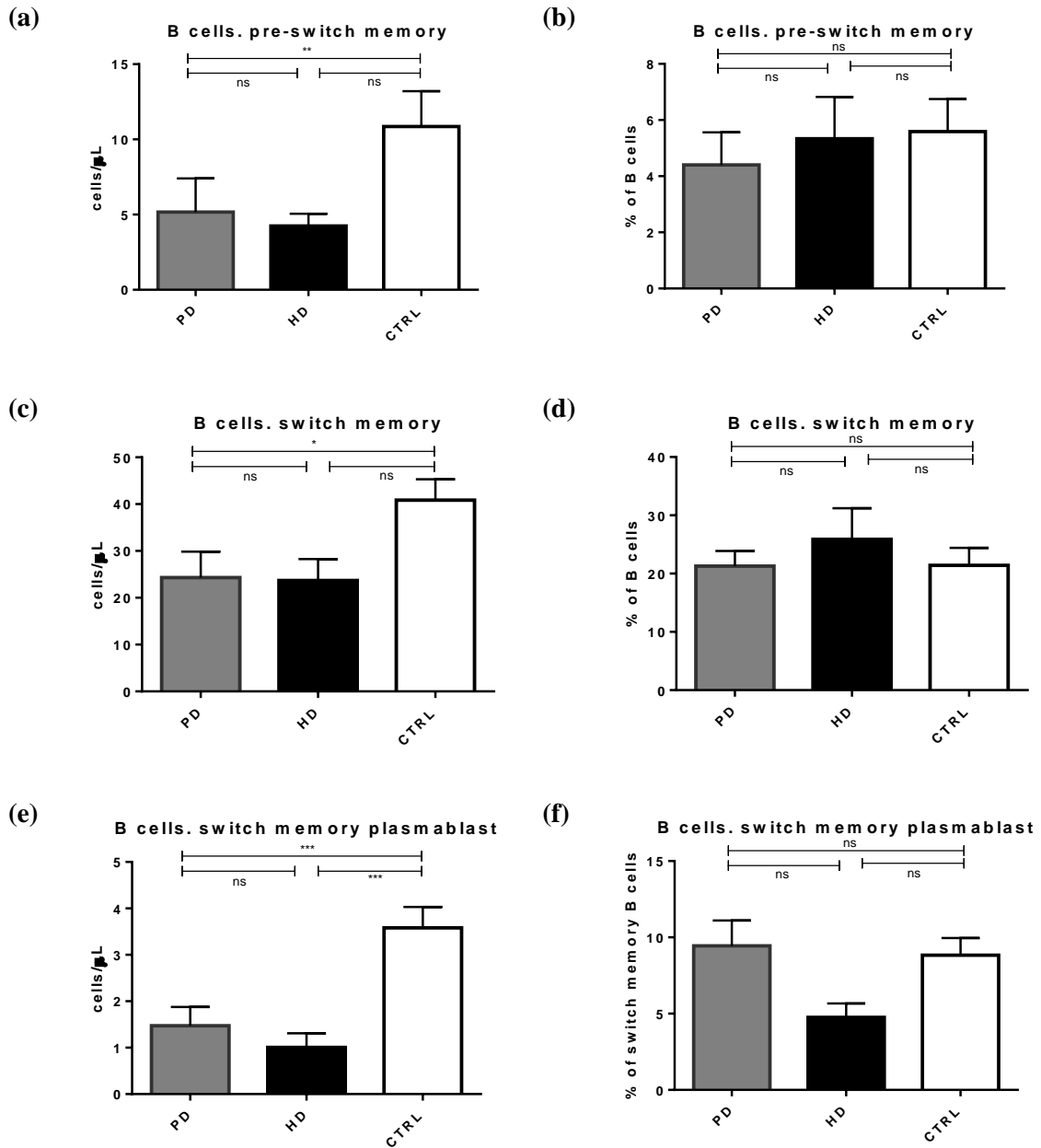
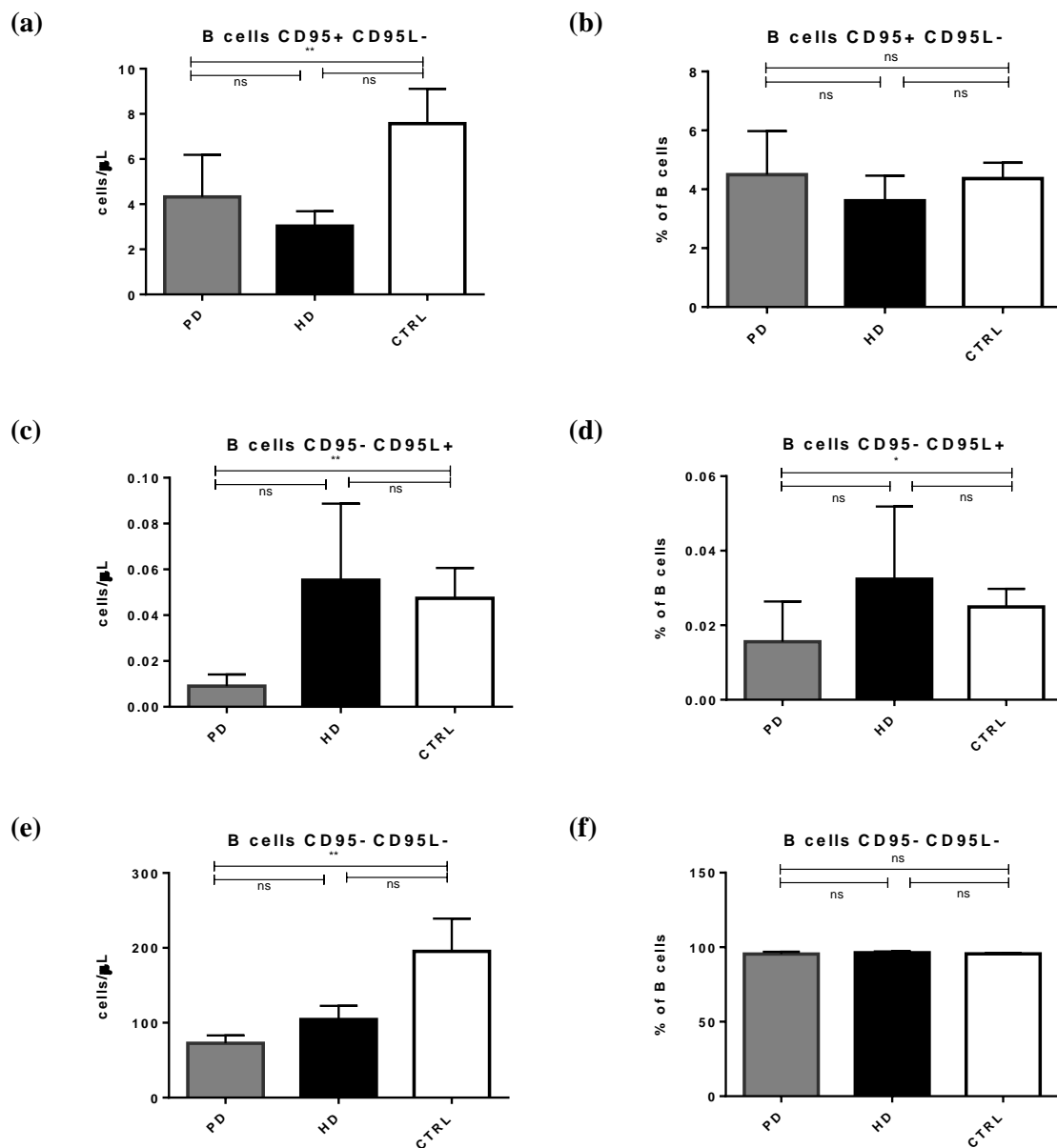

**Figure 11.** Analysis of the absolute frequency of Pre-switch Memory B cells (a), Switch Memory B cells (c) and Plasmablast Switch Memory B cells (e); and Pre-switch Memory B cells as a percentage of B cells (b), Switch Memory B cells as a percentage of B cells (d) and Plasmablast Switch Memory B cells as a percentage of Switch Memory B cells (f) in the PD, HD and CTRL groups. One-way ANOVA test was used to compare the different groups. ns: not significant; \*, \*\*, \*\*\*: statistically significant (\*  $p < 0.05$ , \*\*  $p < 0.01$  and \*\*\*  $p < 0.001$ ).

It can be observed in Figure 11 that a statistically significant difference is seen between total pre-switch memory, switch memory and switch memory plasmablast B cells in the PD comparatively to the CTRL group. The same applies to switch memory

plasmablast B cells in the HD group. Although also decreased in the HD group comparatively to the CTRL group, the difference is not statistically significant in pre-switch memory and switch memory B cells. However, the percentage in parent population shows no statistical significance among the three analyzed groups.

Figure 12 presents the comparison of the expression of CD95 and CD95L in the different groups, as an absolute frequency and as percentage of total B cells.



## Results

**Figure 12.** Analysis of the absolute frequency of CD95<sup>+</sup> CD95L<sup>-</sup> B cells (a), CD95<sup>-</sup> CD95L<sup>+</sup> B cells (c) and CD95<sup>-</sup> CD95L<sup>-</sup> B cells (e); and CD95<sup>+</sup> CD95L<sup>-</sup> B cells (b), CD95<sup>-</sup> CD95L<sup>+</sup> B cells (d) and CD95<sup>-</sup> CD95L<sup>-</sup> B cells(f) as a percentage of B cells in the PD, HD and CTRL groups. One-way ANOVA test was used to compare the different groups. ns: not significant; \*, \*\*, \*\*\*: statistically significant (\* p<0.05, \*\* p<0.01 and \*\*\* p<0.001).

As seen in Figure 12, a statistically significant difference is observed between CD95<sup>+</sup> CD95L<sup>-</sup>, CD95<sup>-</sup> CD95L<sup>+</sup> and CD95<sup>-</sup> CD95L<sup>-</sup> B cells in the PD comparatively to the CTRL group. Although also decreased in the HD group comparatively to the CTRL group, the difference is not statistically significant in CD95<sup>+</sup> CD95L<sup>-</sup> and CD95<sup>-</sup> CD95L<sup>-</sup> B cells. However, the percentage in parent population shows no statistical significance among the three analyzed groups. The percentage in B cells population is decreased in CD95<sup>-</sup> CD95L<sup>+</sup> B cells with a statistically significant difference between the PD and the CTRL group.

## 2 T cells

Another subpopulations studied were the T cells. These were obtained from the lymphocyte population, and are characterized by the presence of CD3. The T cells are a large group of cells that can be further divided according to the expression of CD4 and CD8. As a result, there are two main populations of T cells: the T CD4 cells and the T CD8 cells. These populations can further be characterized according to their function or activation state.

### 2.1 T CD4 cell subsets

T CD4 cells are characterized by the presence of CD3 and CD4, and by the absence of CD8. *Naïve* T CD4 cells can differentiate into effector or memory populations, with distinctive surface antibodies, or by their state of activation. Table III presents the results of such evaluation for the T CD4 cell subpopulation.

**Table III.** T CD4 cell populations from PD, HD and CTRL groups, evaluated by flow cytometry, and their distinctive monoclonal antibodies. The groups were analyzed using One-way ANOVA test. ns: not significant; \*, \*\*, \*\*\*: statistically significant (\* p<0.05, \*\* p<0.01 and \*\*\* p<0.001).

Population	Distinctive antibodies	PD vs HD	PD vs CTRL	HD vs CTRL
T CD4 cells	CD3 <sup>+</sup> CD4 <sup>+</sup>	ns	ns	ns
Central Memory T CD4 cells	CCR7 <sup>+</sup> CD45 <sup>-</sup>	ns	*	ns
Effector T CD4 cells	CCR7 <sup>-</sup> CD45 <sup>+</sup>	ns	*	ns
Effector Memory T CD4 cells	CCR7 <sup>-</sup> CD45 <sup>-</sup>	ns	ns	*
<i>Naïve</i> T CD4 cells	CCR7 <sup>+</sup> CD45 <sup>+</sup>	ns	ns	ns
Activated T CD4 cells	CD38 <sup>+</sup> HLA-DR <sup>+</sup>	ns	****	ns
T CD4 cells CD25 <sup>+</sup>	---	ns	ns	ns
T CD4 cells CD26 <sup>+</sup>	---	ns	ns	ns

## Results

Figure 13 presents the comparison of T CD4 cell population in the different groups, as an absolute frequency and as percentage of CD3 lymphocytes.

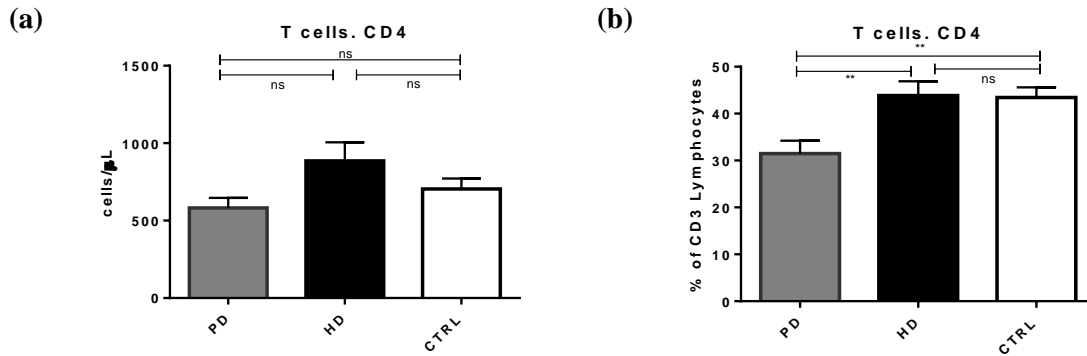
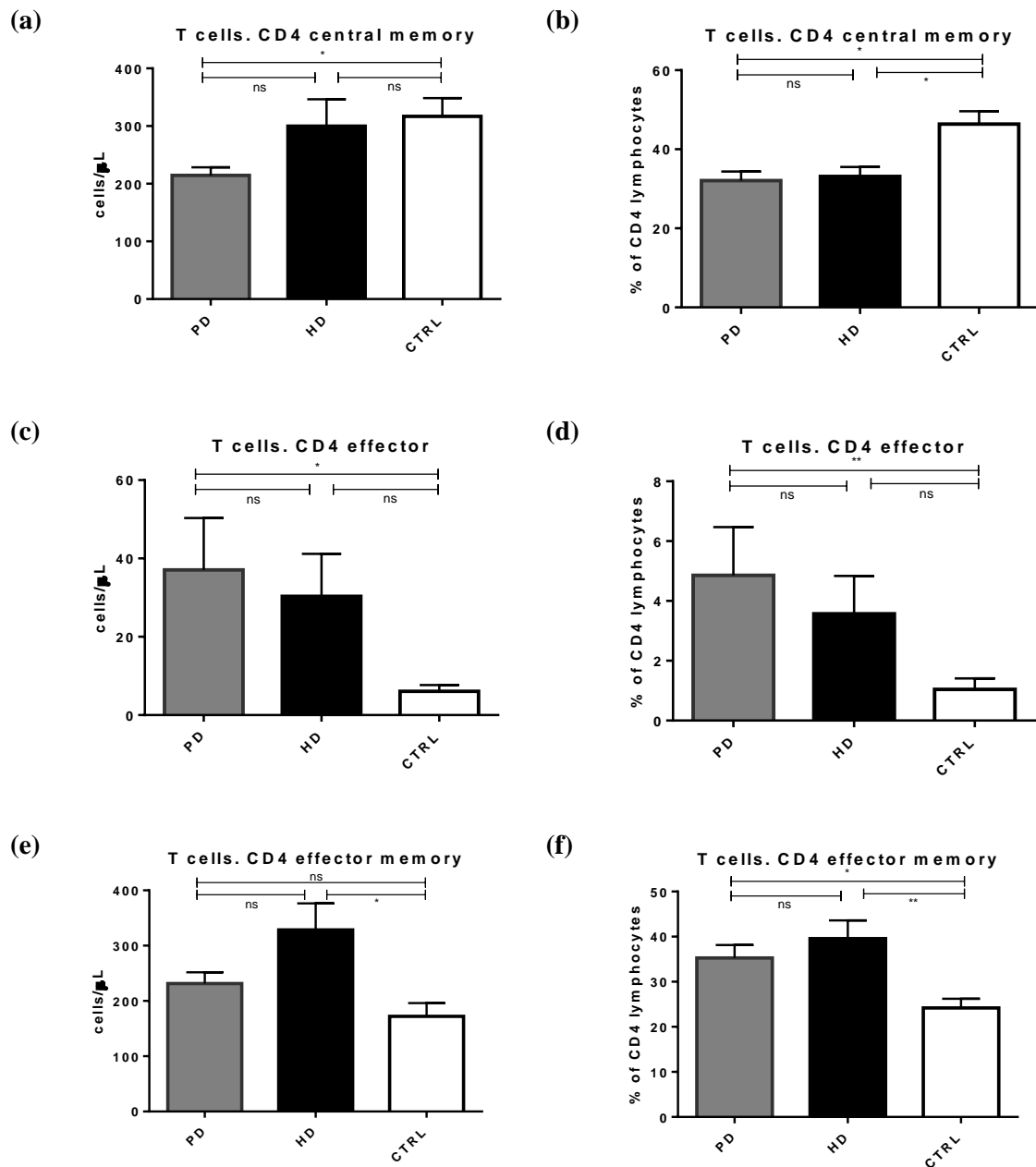

**Figure 13.** Analysis of the absolute frequency (a) and as a percentage of CD3 lymphocytes (b) of T CD4 cells in the PD, HD and CTRL groups. One-way ANOVA test was used to compare the different groups. ns: not significant; \*, \*\*, \*\*\*: statistically significant (\* p<0.05, \*\* p<0.01 and \*\*\* p<0.001).

As seen in Figure 13, the absolute frequency of T CD4 cells shows no statistically significant differences between the three groups. The percentage in CD3 lymphocytes is decreased in T CD4 cells with a statistically significant difference to between the PD and the CTRL group.

Figure 14 presents the comparison of central memory, effector and effector memory T CD4 cell subpopulation in the different groups, as an absolute frequency and as percentage of CD4 lymphocytes.





**Figure 14.** Analysis of the absolute frequency of Central Memory T CD4 cells (a), Effector T CD4 cells (c) and Effector Memory T CD4 cells (e); and Central Memory T CD4 cells (b), Effector T CD4 cells (d) and Effector Memory T CD4 cells (f) as a percentage of T CD4 cells in the PD, HD and CTRL groups. One-way ANOVA test was used to compare the different groups. ns: not significant; \*, \*\*, \*\*\*: statistically significant (\* p<0.05, \*\* p<0.01 and \*\*\* p<0.001).

From the observation of Figure 14, the absolute frequency of central memory T CD4 cells is diminished, while the absolute frequency of effector T CD4 cells is increased in the patients. Statistically significant differences were shown between the

## Results

PD and CTRL groups. Effector Memory T CD4 cells show a statistically significant increase in the HD group. The same differences were observed when evaluated as a percentage of CD4 lymphocytes.

Figure 15 presents the comparison of activated T CD4 cell subpopulation in the different groups, as an absolute frequency and as percentage of CD4 lymphocytes.

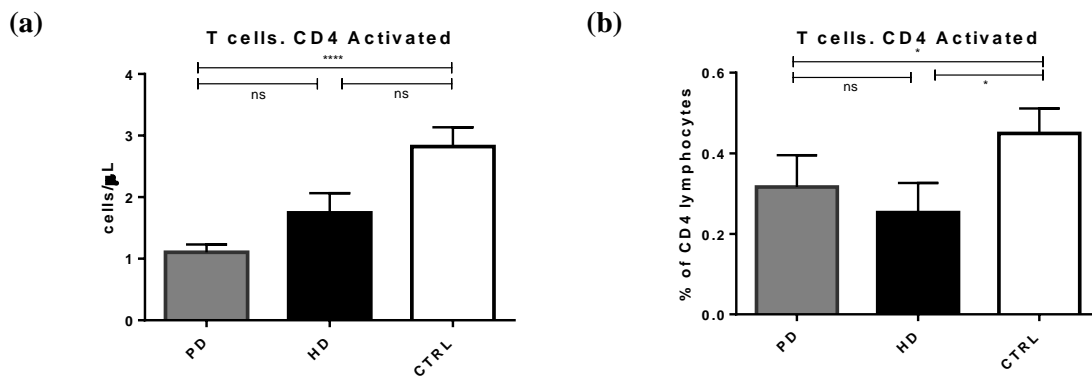

**Figure 15.** Analysis of the absolute frequency (a) and as a percentage of CD4 lymphocytes (b) of Activated T CD4 cells in the PD, HD and CTRL groups. One-way ANOVA test was used to compare the different groups. ns: not significant; \*, \*\*, \*\*\*: statistically significant (\*  $p < 0.05$ , \*\*  $p < 0.01$  and \*\*\*  $p < 0.001$ ).

Figure 15 shows a statistically significant decrease in the absolute frequency of activated T CD4 cells in the PD group. However, activated T CD4 cells are decreased in both the PD and HD groups when analyzed as a percentage of CD4 lymphocytes.

### 2.1.1 T helper cells

T CD4 cells can also be categorized into T helper cells 1, 2 and 17, depending on the expression of CXCR3 and CCR6, as seen in Table IV.

**Table IV.** T helper cell populations from PD, HD and CTRL groups, evaluated by flow cytometry, and their distinctive monoclonal antibodies. The groups were analyzed using One-way ANOVA test. ns: not significant; \*, \*\*, \*\*\*: statistically significant (\*  $p < 0.05$ , \*\*  $p < 0.01$  and \*\*\*  $p < 0.001$ ).

Population	Distinctive antibodies	PD vs HD	PD vs CTRL	HD vs CTRL
Th1	CD4 <sup>+</sup> CXCR3 <sup>+</sup> CCR6 <sup>-</sup>	ns	*	ns
Th2	CD4 <sup>+</sup> CXCR3 <sup>-</sup> CCR6 <sup>-</sup>	ns	ns	ns
Th17	CD4 <sup>+</sup> CXCR3 <sup>-</sup> CCR6 <sup>+</sup>	ns	**	ns

Figure 16 presents the comparison of activated Th1 and Th17 cell populations in the different groups, as an absolute frequency and as percentage of CD4 lymphocytes.

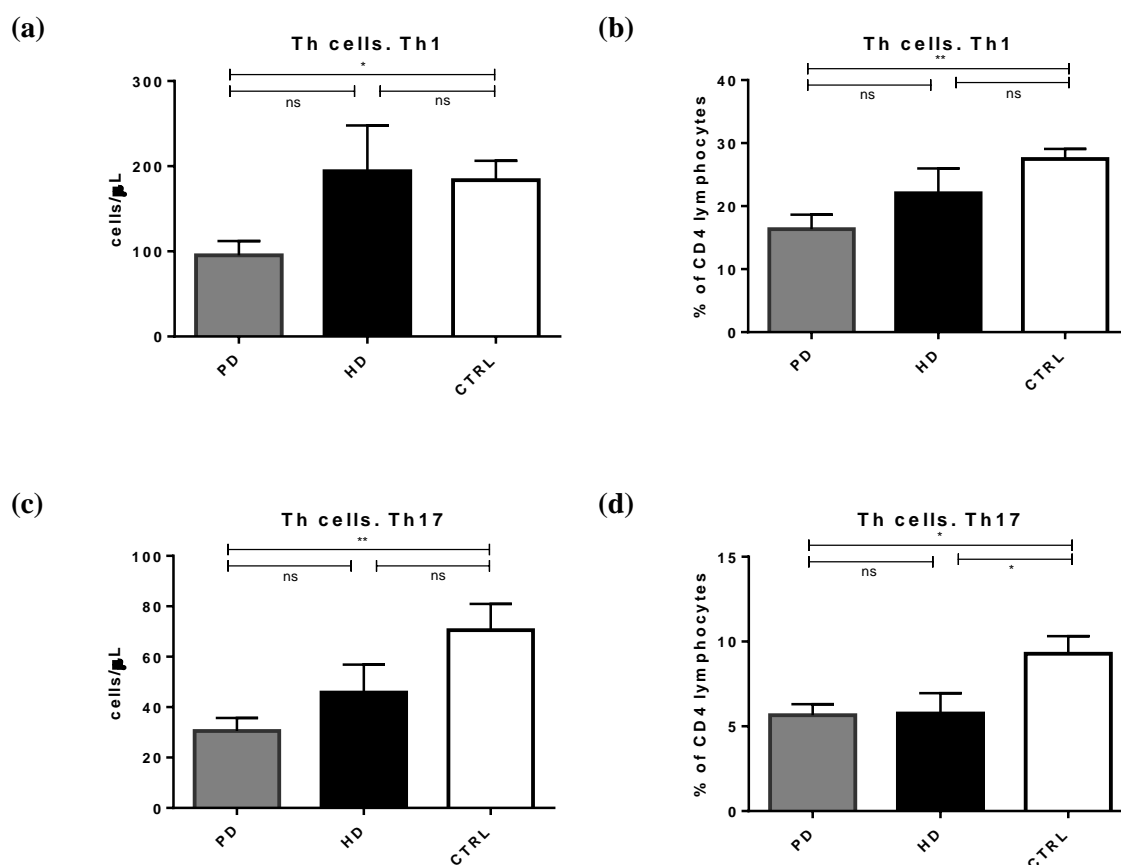

**Figure 16.** Analysis of the absolute frequency of Th1 cells (a) and Th17 cells (c); and Th1 cells (b) and Th17 cells (d) as a percentage of T CD4 cells in the PD, HD and CTRL groups. One-way ANOVA test was used to compare the different groups. ns: not significant; \*, \*\*, \*\*\*: statistically significant (\*  $p < 0.05$ , \*\*  $p < 0.01$  and \*\*\*  $p < 0.001$ ).

As seen in Figure 16, a statistically significant difference is seen between Th1 and Th17 cells in the PD and the CTRL groups. Although also decreased in the HD comparatively to the CTRL group, the difference is not statistically significant. The percentage in CD4 lymphocytes is also decreased in the PD and HD groups with a statistically significant difference in the PD group.

### 2.1.2 T regulatory cells

Regulatory T cells are another population of T CD4 cells, characterized by the expression of CCR4, CD25 and low expression of CD127. They can also be characterized by the expression of FoxP3. Table V presents the results of such evaluation for the T regulatory cell subpopulation.

**Table V.** Treg cell populations from PD, HD and CTRL groups, evaluated by flow cytometry, and their distinctive monoclonal antibodies. The groups were analyzed using One-way ANOVA test. ns: not significant; \*, \*\*, \*\*\*: statistically significant (\* p<0.05, \*\* p<0.01 and \*\*\* p<0.001).

Population	Distinctive antibodies	PD vs HD	PD vs CTRL	HD vs CTRL
Treg	CD4 <sup>+</sup> CCR4 <sup>+</sup> CD25 <sup>+</sup> CD127 <sup>low</sup>	ns	*	ns
Activated Treg	HLA-DR <sup>+</sup>	ns	****	*
FoxP3 Treg	FoxP3 <sup>+</sup>	ns	ns	ns
FoxP3 Treg IL10 <sup>+</sup>	---	ns	****	****
FoxP3 Treg TGF- $\beta$ <sup>+</sup>	---	ns	*	*

Figure 17 presents the comparison of activated Treg and activated Treg cell populations in the different groups, as an absolute frequency and as percentage of the parent population.

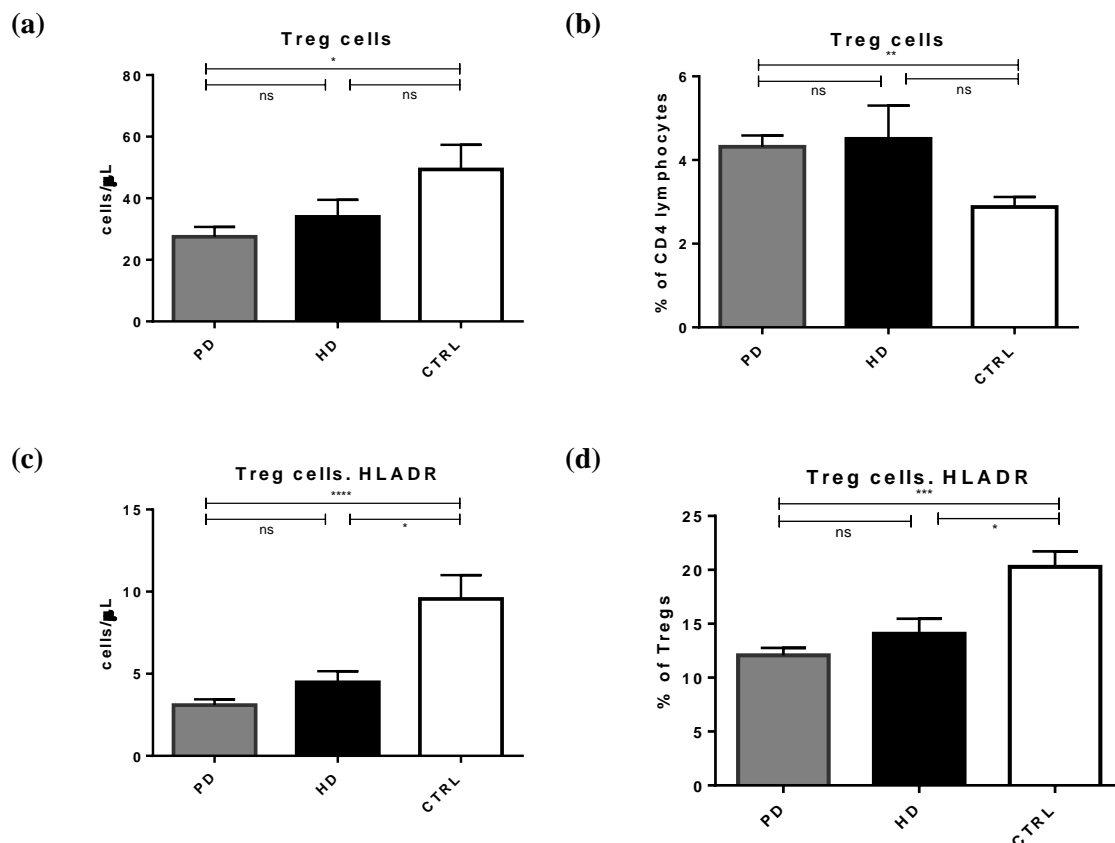
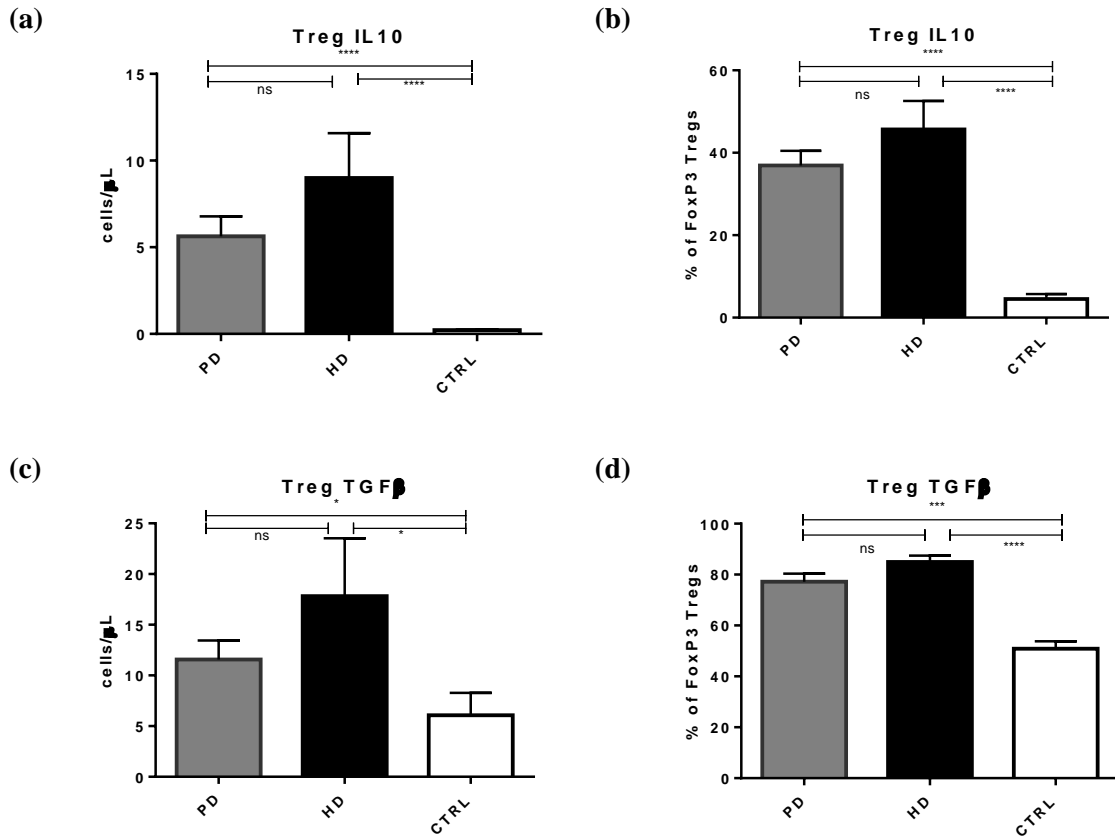

**Figure 17.** Analysis of the absolute frequency of Treg cells (a) and Activated Treg cells (c); and Treg cells as a percentage of T CD4 cells (b) and Activated Treg cells as a percentage of Treg cells (d) in the PD, HD and CTRL groups. One-way ANOVA test was used to compare the different groups. ns: not significant; \*, \*\*, \*\*\*: statistically significant (\*  $p < 0.05$ , \*\*  $p < 0.01$  and \*\*\*  $p < 0.001$ ).

As seen in Figure 17, a statistically significant difference is seen between Treg cells in the PD and the CTRL groups, as well as between activated Treg cells in the patients groups in comparison to the CTRL groups. The percentage in the parent population shows an increase in Treg cells, with a statistically significant difference in the PD group; and decrease in activated Treg cells with a statistically significant difference in the PD and HD groups.

Figure 18 presents the comparison in the production of IL-10 and TGF- $\beta$  by Treg cells in the different groups, as an absolute frequency and as percentage of FoxP3 Treg cells.

## Results



**Figure 18.** Analysis of the absolute frequency of IL-10<sup>+</sup> Treg cells (a) and TGF-β<sup>+</sup> Treg cells (c); and IL-10<sup>+</sup> Treg cells (b) and TGF-β<sup>+</sup> Treg cells (d) as a percentage of FoxP3 Treg cells in the PD, HD and CTRL groups. One-way ANOVA test was used to compare the different groups. ns: not significant; \*, \*\*, \*\*\*: statistically significant (\* p<0.05, \*\* p<0.01 and \*\*\* p<0.001).

As seen in Figure 18, a statistically significant difference is seen in both cytokines between the PD and HD groups, and the CTRL group. The percentage in the FoxP3 Treg cells also shows a statistically significant increase in both groups.

## 2.2 T CD8 cell subsets

T CD8 cells are characterized by the presence of CD3 and CD8, and by the absence of CD4. Similarly to T CD4 cells, T CD8 cells can also be distinguished by expression of different surface molecules, indicative of their function and their state of activation, as seen in Table VI.

**Table VI.** T CD8 cell populations from PD, HD and CTRL groups, evaluated by flow cytometry, and their distinctive monoclonal antibodies. The groups were analyzed using One-way ANOVA test. ns: not significant; \*, \*\*, \*\*\*: statistically significant (\*  $p < 0.05$ , \*\*  $p < 0.01$  and \*\*\*  $p < 0.001$ ).

Population	Distinctive antibodies	PD vs HD	PD CTRL vs	HD CTRL vs
T CD8 cells	CD3 <sup>+</sup> CD8 <sup>+</sup>	ns	ns	ns
Activated T CD8 cells	CD38 <sup>+</sup> HLA-DR <sup>+</sup>	ns	ns	ns
Central Memory T CD8 cells	CCR7 <sup>+</sup> CD45 <sup>-</sup>	ns	***	ns
Effector T CD8 cells	CCR7 <sup>-</sup> CD45 <sup>+</sup>	ns	ns	ns
Effector low T CD8 cells	CCR7 <sup>-</sup> CD45 <sup>low</sup>	ns	ns	ns
Effector Memory T CD8 cells	CCR7 <sup>-</sup> CD45 <sup>-</sup>	ns	ns	ns
Naïve T CD8 cells	CCR7 <sup>+</sup> CD45 <sup>+</sup>	ns	ns	ns
Naïve low T CD8 cells	CCR7 <sup>+</sup> CD45 <sup>low</sup>	ns	ns	ns
T CD8 cells CD25 <sup>+</sup>	---	ns	ns	ns
T CD8 cells CD26 <sup>+</sup>	---	ns	ns	ns

Figure 19 presents the comparison of T CD8 cell population in the different groups, as an absolute frequency and as percentage of CD3 lymphocytes.

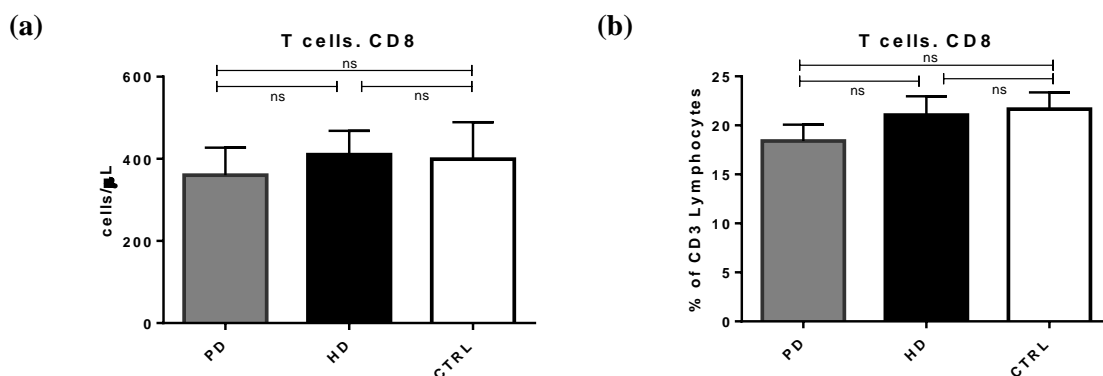
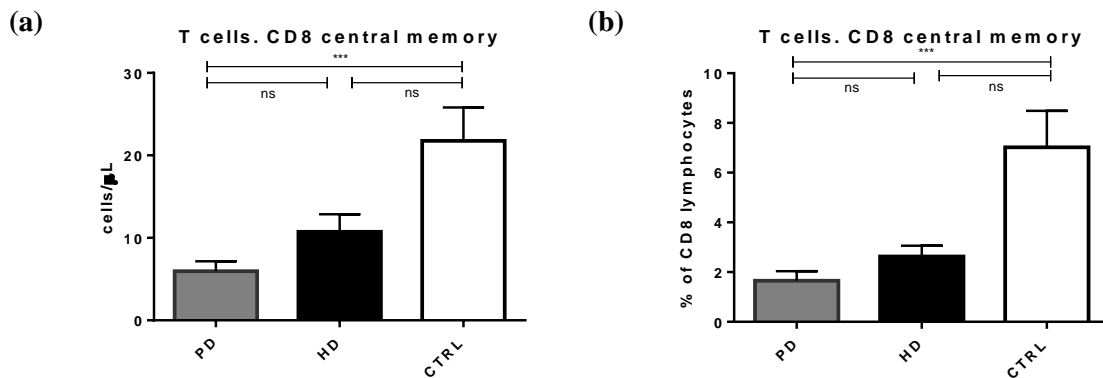

**Figure 19.** Analysis of the absolute frequency (a) and as a percentage of CD3 lymphocytes (b) of T CD8 cells in the PD, HD and CTRL groups. One-way ANOVA test was used to compare the different groups. ns: not significant; \*, \*\*, \*\*\*: statistically significant (\*  $p < 0.05$ , \*\*  $p < 0.01$  and \*\*\*  $p < 0.001$ ).

## Results

As seen in Figure 19, both the absolute frequency of T CD8 cells and the percentage in CD3 lymphocytes show no statistically significant differences.

Figure 20 presents the comparison of central memory T CD8 cell population in the different groups, as an absolute frequency and as percentage of CD3 lymphocytes.



**Figure 20.** Analysis of the absolute frequency (a) and the percentage in CD8 lymphocytes (b) of Central Memory T CD8 cells in the PD, HD and CTRL groups. One-way ANOVA test was used to compare the different groups. ns: not significant; \*, \*\*, \*\*\*: statistically significant (\*  $p < 0.05$ , \*\*  $p < 0.01$  and \*\*\*  $p < 0.001$ ).

As seen in Figure 20, both the absolute frequency of central memory T CD8 cells and the percentage in CD8 lymphocytes show statistically significant decrease in the PD group.



### 3 Monocyte subsets

Monocytes are another of the cell populations evaluated. These are measured from the monocyte gate in Figure 15 and are characterized by the expression of CD14 and the absence of CD3 and CD19. Monocytes can be distinguished into classical and non-classical, according to the expression of CD16, and by the expression of surface molecules. Table VII presents the results of such evaluation for the monocytes.

**Table VII.** Monocyte populations from PD, HD and CTRL groups, evaluated by flow cytometry, and their distinctive monoclonal antibodies. The groups were analyzed using One-way ANOVA test. ns: not significant; \*, \*\*, \*\*\*: statistically significant (\*  $p < 0.05$ , \*\*  $p < 0.01$  and \*\*\*  $p < 0.001$ ).

Population	Distinctive antibodies	PD vs HD	PD vs CTRL	HD vs CTRL
Monocytes	CD3 <sup>-</sup> CD19 <sup>-</sup> CD14 <sup>+</sup>	ns	*	***
Classical	CD16 <sup>-</sup>	ns	**	****
Non-Classical	CD16 <sup>+</sup>	ns	ns	ns
CD95 <sup>+</sup> CD95L <sup>-</sup>	---	ns	ns	ns
CD95 <sup>-</sup> CD95L <sup>+</sup>	---	ns	ns	ns
CD95 <sup>+</sup> CD95L <sup>+</sup>	---	ns	ns	ns
CD95 <sup>-</sup> CD95L <sup>-</sup>	---	ns	**	ns

Figure 21 presents the comparison of the monocyte population in the different groups, as an absolute frequency and as percentage of lymphocyte and monocyte population.

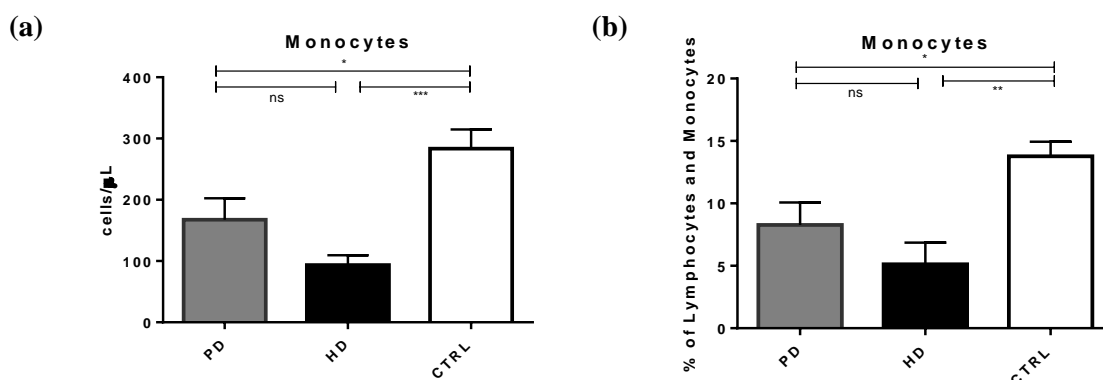

## Results

**Figure 21.** Analysis of the absolute frequency (a) and as a percentage of total lymphocytes and monocytes(b) of Monocytes in the PD, HD and CTRL groups. One-way ANOVA test was used to compare the different groups. ns: not significant; \*, \*\*, \*\*\*: statistically significant (\*  $p < 0.05$ , \*\*  $p < 0.01$  and \*\*\*  $p < 0.001$ ).

As seen in Figure 20, both the absolute frequency of monocytes and the percentage in the lymphocytes and monocyte population show a statistically significant decrease in both the PD and HD groups.

Figure 22 presents the comparison of the classical monocyte population in the different groups, as an absolute frequency and as percentage of monocytes.

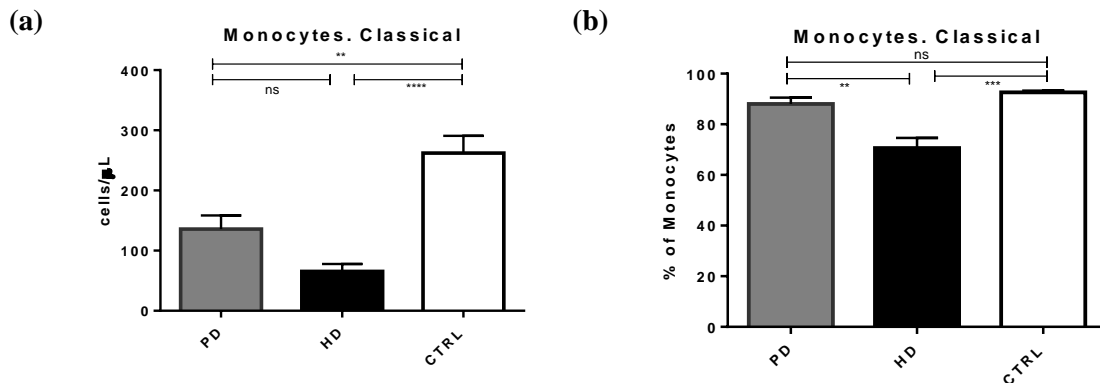

**Figure 22.** Analysis of the absolute frequency (a) and as a percentage of total monocytes (b) of Classical Monocytes in the PD, HD and CTRL groups. One-way ANOVA test was used to compare the different groups. ns: not significant; \*, \*\*, \*\*\*: statistically significant (\*  $p < 0.05$ , \*\*  $p < 0.01$  and \*\*\*  $p < 0.001$ ).

Figure 22 shows a statistically significant difference in both the PD and HD groups in the absolute frequency of classical monocytes. The HD group shows a statistically significant decrease in classical monocytes as a percentage of total monocytes.

Figure 23 presents the comparison of the CD95<sup>-</sup> CD95L<sup>-</sup> monocyte population in the different groups, as an absolute frequency and as percentage of monocytes.

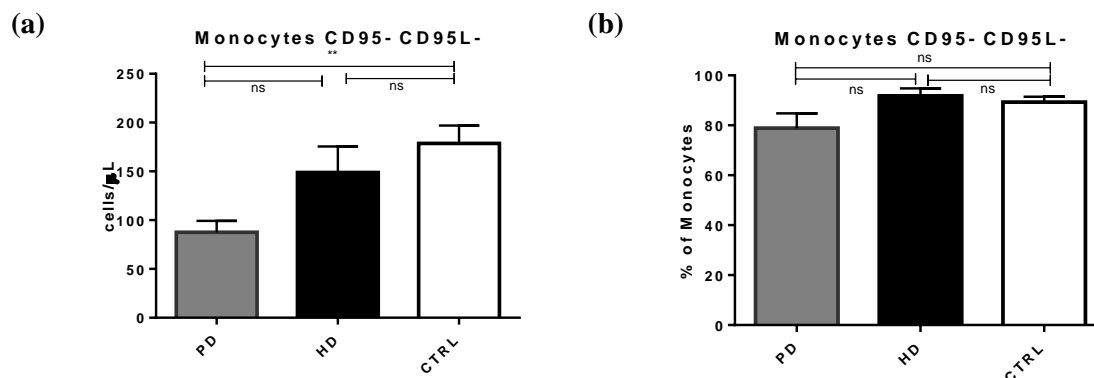

**Figure 23.** Analysis of the absolute frequency (a) and as a percentage of total monocytes (b) of CD95<sup>-</sup> CD95L<sup>-</sup> Monocytes in the PD, HD and CTRL groups. One-way ANOVA test was used to compare the different groups. ns: not significant; \*, \*\*, \*\*\*: statistically significant (\* p<0.05, \*\* p<0.01 and \*\*\* p<0.001).

Figure 23 shows that CD95<sup>-</sup> CD95L<sup>-</sup> monocytes are significantly decreased in the PD. As a percentage of total monocytes, CD95<sup>-</sup> CD95L<sup>-</sup> monocytes show no statistically significant differences.

### 3.1 Dendritic cells

Dendritic cells are a population, derived from monocytes, characterized by the absence of CD3, CD19, CD14 and CD20, and by the expression of human leukocyte antigen-DR (HLA-DR). Dendritic cells can be classified into myeloid or plasmacytoid, depending on the expression of CD11c and CD123, respectively. Table VIII presents the results of such evaluation for dendritic cells.

## Results

**Table VIII.** Dendritic cell populations from PD, HD and CTRL groups, evaluated by flow cytometry, and their distinctive monoclonal antibodies. The groups were analyzed using One-way ANOVA test. ns: not significant; \*, \*\*, \*\*\*: statistically significant (\*  $p < 0.05$ , \*\*  $p < 0.01$  and \*\*\*  $p < 0.001$ ).

Population	Distinctive antibodies	PD vs HD	PD vs CTRL	HD vs CTRL
Dendritic cells	CD3 <sup>-</sup> CD19 <sup>-</sup> CD14 <sup>-</sup> CD20 <sup>-</sup> HLA-DR <sup>+</sup>	ns	***	**
Myeloid Dendritic cells	CD11c <sup>+</sup>	ns	**	*
Plasmacytoid Dendritic cells	CD123 <sup>+</sup>	ns	**	*

Figure 24 presents the comparison of the dendritic cell population in the different groups, as an absolute frequency and as percentage of lymphocytes and monocytes.

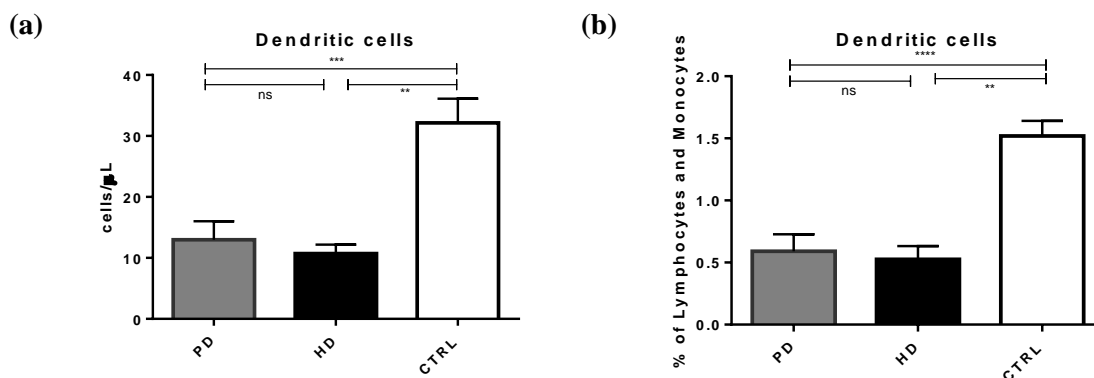

**Figure 24.** Analysis of the absolute frequency (a) and as a percentage of total lymphocytes and monocytes (b) of Dendritic cells in the PD, HD and CTRL groups. One-way ANOVA test was used to compare the different groups. ns: not significant; \*, \*\*, \*\*\*: statistically significant (\*  $p < 0.05$ , \*\*  $p < 0.01$  and \*\*\*  $p < 0.001$ ).

Figure 24 shows a statistically significant decrease in both the PD and HD groups in the absolute frequency of dendritic cells.

Figure 25 presents the comparison of the myeloid and plasmacytoid dendritic cell populations in the different groups, as an absolute frequency and as percentage of dendritic cells.

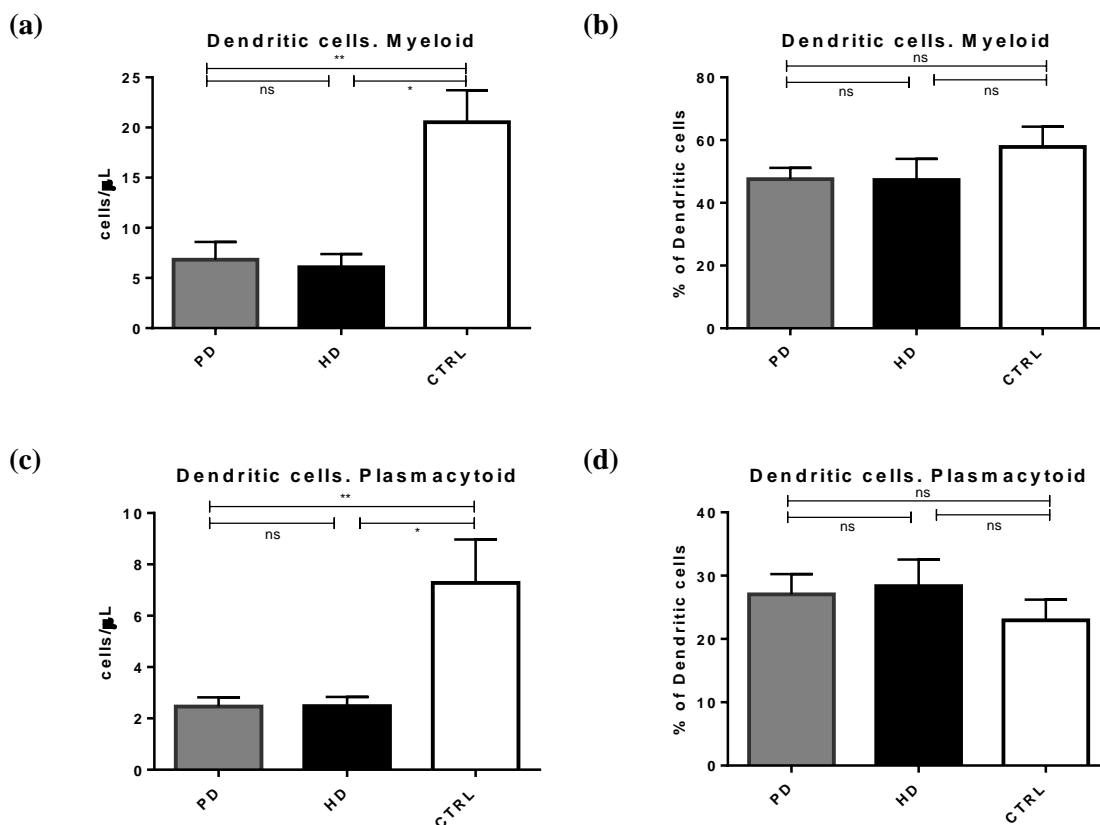

**Figure 25.** Analysis of the absolute frequency of Myeloid Dendritic cells (a) and Plasmacytoid Dendritic cells (c); and Myeloid Dendritic cells (b) and Plasmacytoid Dendritic cells (d) as a percentage of Dendritic cells in the PD, HD and CTRL groups. One-way ANOVA test was used to compare the different groups. ns: not significant; \*, \*\*, \*\*\*: statistically significant (\* p<0.05, \*\* p<0.01 and \*\*\* p<0.001).

As seen in Figure 25, a statistically significant difference is seen in myeloid and plasmacytoid dendritic cells between the PD and HD groups, and the CTRL group. The percentage in the dendritic cells shows no statistically significant difference.

## 4 Invariant NKT and $\gamma\delta$ T cells

### 4.1 iNKT cells

iNKT cells are a T cell population, characterized by the expression of NK cell receptors. As such, they are characterized by the expression of iNKT. As seen in Table IX, the expression of several surface molecules was evaluated in these cells, as well as their ability to express several cytokines.

**Table IX.** iNKT cell populations from PD, HD and CTRL groups, evaluated by flow cytometry, and their distinctive monoclonal antibodies. The groups were analyzed using One-way ANOVA test. ns: not significant; \*, \*\*, \*\*\*: statistically significant (\* p<0.05, \*\* p<0.01 and \*\*\* p<0.001).

Population	PD vs HD	PD vs CTRL	HD vs CTRL
iNKT	ns	ns	ns
iNKT CD137 <sup>+</sup> CD137L <sup>-</sup>	ns	ns	ns
iNKT CD137 <sup>-</sup> CD137L <sup>+</sup>	ns	ns	*
iNKT CD137 <sup>+</sup> CD137L <sup>+</sup>	ns	ns	ns
iNKT CD137 <sup>-</sup> CD137L <sup>-</sup>	ns	ns	ns
iNKT CD8 <sup>+</sup>	ns	ns	ns
iNKT CD57 <sup>+</sup>	ns	ns	ns
iNKT CD69 <sup>+</sup>	ns	ns	ns
iNKT CD25 <sup>+</sup>	ns	*	ns
iNKT CD25 <sup>+</sup> IFN- $\gamma$	ns	ns	ns
iNKT CD25 <sup>+</sup> TNF- $\alpha$	ns	ns	ns
iNKT CD62L <sup>+</sup>	ns	ns	*
iNKT CD62L <sup>+</sup> IFN- $\gamma$	ns	ns	ns
iNKT CD62L <sup>+</sup> TNF- $\alpha$	ns	ns	ns

Figure 26 presents the comparison of invariant NKT cell population in the different groups, as an absolute frequency and as percentage of lymphocytes.

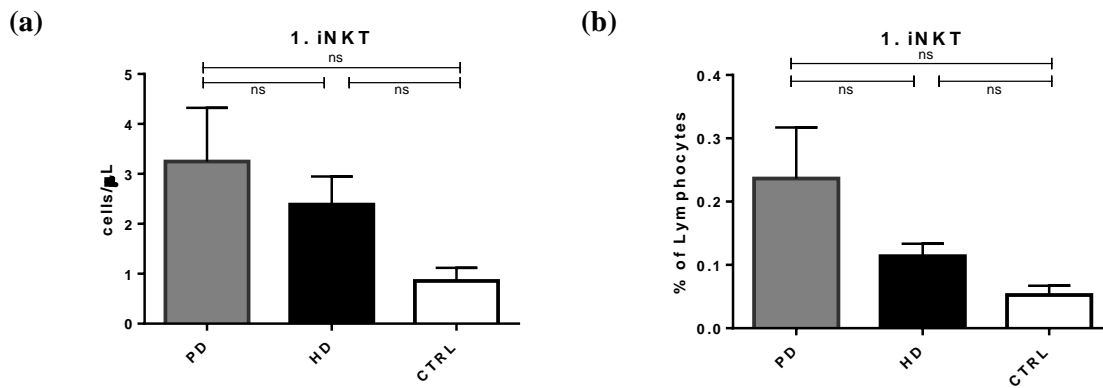
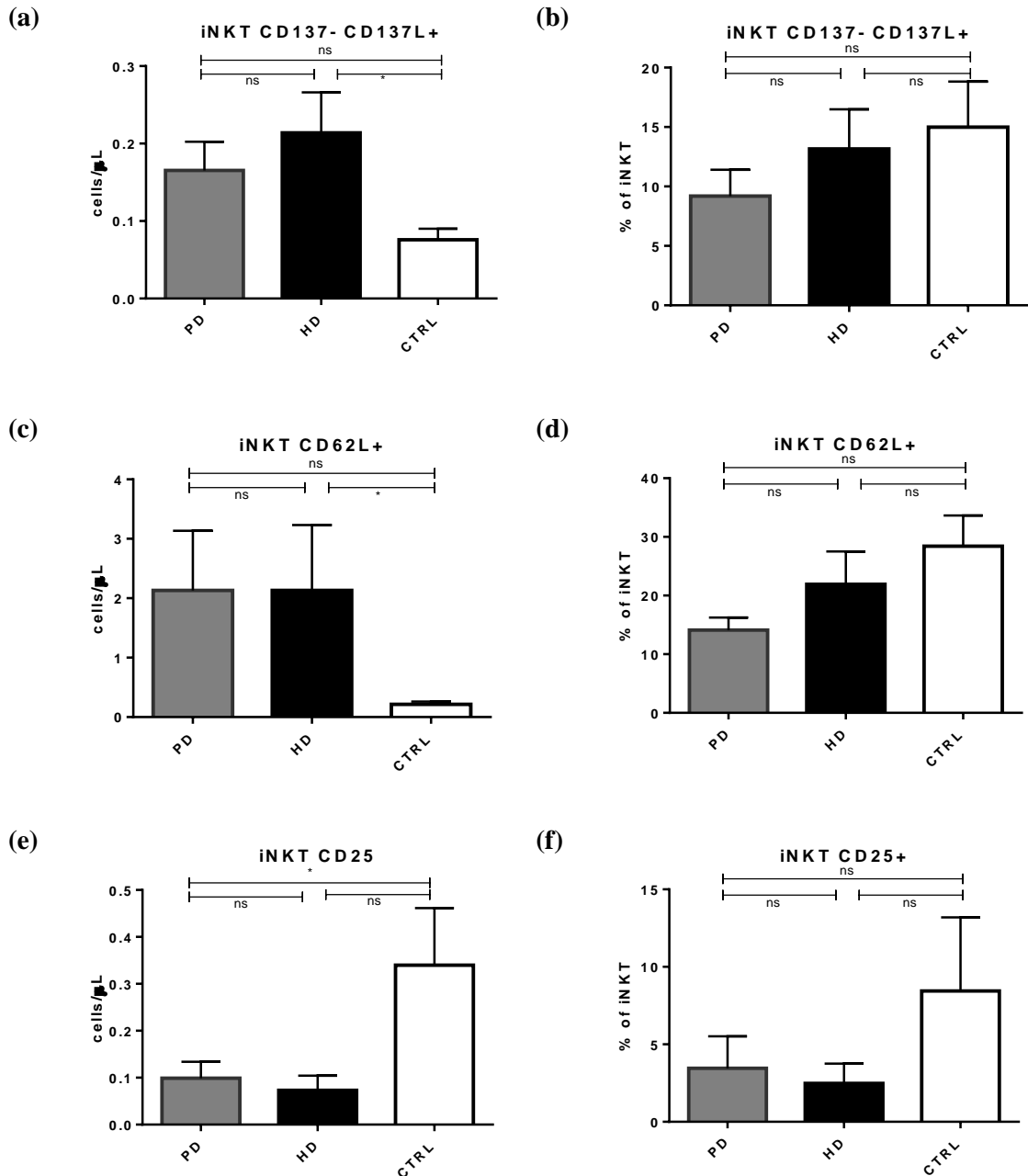

**Figure 26.** Analysis of the absolute frequency (a) and as a percentage of total lymphocytes (b) of iNKT cells in the PD, HD and CTRL groups. One-way ANOVA test was used to compare the different groups. ns: not significant; \*, \*\*, \*\*\*: statistically significant (\*  $p < 0.05$ , \*\*  $p < 0.01$  and \*\*\*  $p < 0.001$ ).

No statistically significant difference was observed in iNKT cells in both the PD and HD groups (Figure 26).

Figure 27 presents the comparison of the expression of CD137, CD137L, CD62L and CD25 by invariant NKT cells in the different groups, as an absolute frequency and as percentage of iNKT cells.

## Results



**Figure 27.** Analysis of the absolute frequency of CD137<sup>-</sup> CD137L<sup>+</sup> iNKT cells (a), CD62L<sup>+</sup> iNKT cells (c) and CD25<sup>+</sup> iNKT cells (e); and CD137<sup>-</sup> CD137L<sup>+</sup> iNKT (b), CD62L<sup>+</sup> iNKT cells (d) and CD25<sup>+</sup> iNKT cells (f) as a percentage of total iNKT cells in the PD, HD and CTRL groups. One-way ANOVA test was used to compare the different groups. ns: not significant; \*, \*\*, \*\*\*: statistically significant (\* p<0.05, \*\* p<0.01 and \*\*\* p<0.001).

As seen in Figure 27, a statistically significant increase is seen between the absolute frequency of CD137<sup>-</sup> CD137L<sup>+</sup> and CD62L<sup>+</sup> iNKT cells. The absolute frequency of CD25<sup>+</sup> iNKT cells is diminished in both groups, with statistical



significance in PD. The percentage in the iNKT cells shows no statistically significant differences.

## 4.2 $\gamma\delta$ T cells

$\gamma\delta$  T cells are another population of T cells that express neither CD4 nor CD8. Instead, they are characterized by the expression of the  $\gamma\delta$  T cells receptor. The expression of different surface molecules and their ability to express several cytokines was also evaluated in these cells. Table X presents the results of such evaluation for the  $\gamma\delta$  T cell populations.

**Table X.**  $\gamma\delta$  T cell populations from PD, HD and CTRL groups, evaluated by flow cytometry, and their distinctive monoclonal antibodies. The groups were analyzed using One-way ANOVA test. ns: not significant; \*, \*\*, \*\*\*: statistically significant (\* p<0.05, \*\* p<0.01 and \*\*\* p<0.001).

Population	PD vs HD	PD vs CTRL	HD vs CTRL
$\gamma\delta$ T cells	ns	ns	ns
$\gamma\delta$ T CD137 <sup>+</sup> CD137L <sup>-</sup>	ns	*	*
$\gamma\delta$ T CD137 <sup>-</sup> CD137L <sup>+</sup>	ns	**	*
$\gamma\delta$ T CD137 <sup>+</sup> CD137L <sup>+</sup>	ns	ns	ns
$\gamma\delta$ T $\delta$ CD137 <sup>-</sup> CD137L <sup>-</sup>	ns	ns	ns
$\gamma\delta$ T CD25 <sup>+</sup>	ns	****	ns
$\gamma\delta$ T CD25 <sup>+</sup> IFN- $\gamma$	ns	ns	ns
$\gamma\delta$ T CD25 <sup>+</sup> TNF- $\alpha$	ns	ns	ns
$\gamma\delta$ T CD27 <sup>+</sup> CD11b <sup>-</sup>	ns	ns	ns
$\gamma\delta$ T CD27 <sup>-</sup> CD11b <sup>+</sup>	ns	ns	ns
$\gamma\delta$ T CD27 <sup>+</sup> CD11b <sup>+</sup>	ns	ns	ns
$\gamma\delta$ T CD27 <sup>-</sup> CD11b <sup>-</sup>	ns	ns	ns
$\gamma\delta$ T NKp30	ns	ns	ns
$\gamma\delta$ T CD95 <sup>+</sup> CD95L <sup>-</sup>	ns	ns	*
$\gamma\delta$ T CD95 <sup>-</sup> CD95L <sup>+</sup>	ns	ns	ns
$\gamma\delta$ T CD95 <sup>+</sup> CD95L <sup>+</sup>	ns	ns	*
$\gamma\delta$ T CD95 <sup>-</sup> CD95L <sup>-</sup>	ns	ns	ns
$\gamma\delta$ T TLR4 <sup>+</sup>	ns	ns	ns

## Results

Figure 28 presents the comparison of  $\gamma\delta$  T cell population in the different groups, as an absolute frequency and as percentage of lymphocytes.

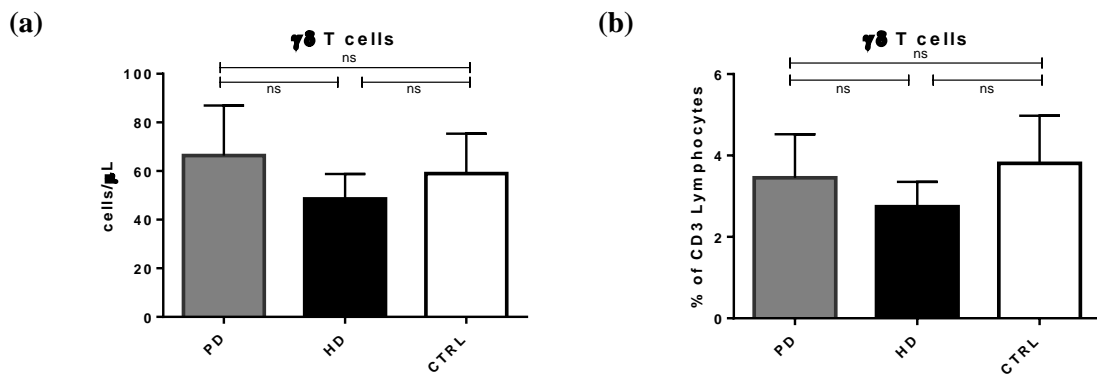

**Figure 28.** Analysis of the absolute frequency (a) and as a percentage of total lymphocytes (b) of  $\gamma\delta$  T cells in the PD, HD and CTRL groups. One-way ANOVA test was used to compare the different groups. ns: not significant; \*, \*\*, \*\*\*: statistically significant (\*  $p < 0.05$ , \*\*  $p < 0.01$  and \*\*\*  $p < 0.001$ ).

As seen in Figure 28, no statistically significant difference is observed between the absolute frequency and the percentage in lymphocytes of  $\gamma\delta$  T cells in the PD and HD groups.

Figure 29 presents the comparison of the expression of CD137 and CD137L by  $\gamma\delta$  T cell population in the different groups, as an absolute frequency and as percentage of  $\gamma\delta$  T cells.

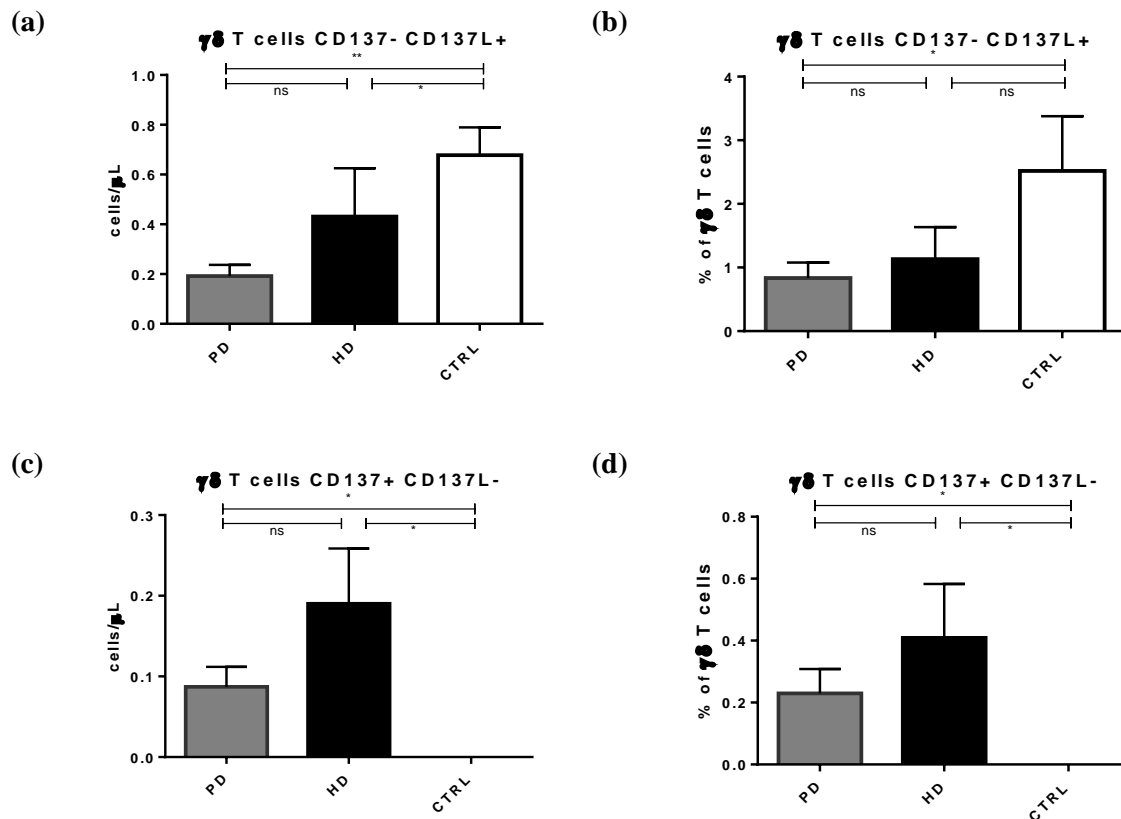
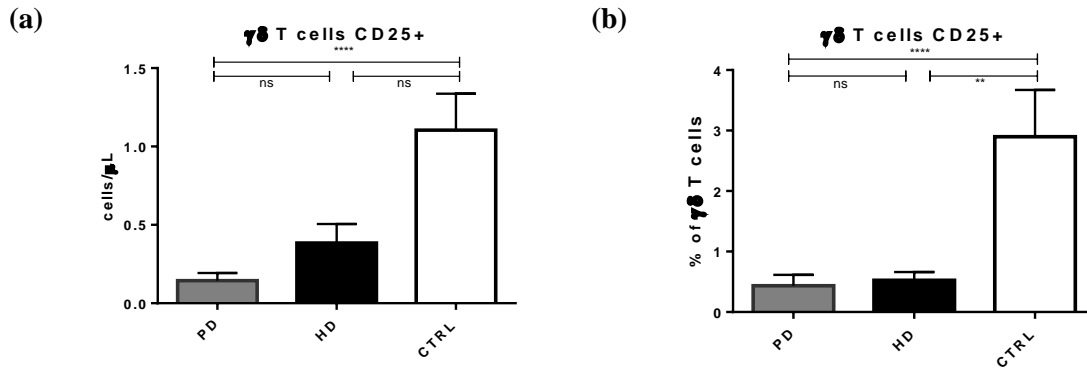

**Figure 29.** Analysis of the absolute frequency of CD137<sup>-</sup> CD137L<sup>+</sup>  $\gamma\delta$  T cells (a) and CD137<sup>+</sup> CD137L<sup>-</sup>  $\gamma\delta$  T cells (c); and CD137<sup>-</sup> CD137L<sup>+</sup>  $\gamma\delta$  T cells (b) and CD137<sup>+</sup> CD137L<sup>-</sup>  $\gamma\delta$  T cells (d) as a percentage of total  $\gamma\delta$  T cells in the PD, HD and CTRL groups. One-way ANOVA test was used to compare the different groups. ns: not significant; \*, \*\*, \*\*\*: statistically significant (\* p<0.05, \*\* p<0.01 and \*\*\* p<0.001).

As seen in Figure 29, a statistically significant decrease is seen in the absolute frequency of CD137<sup>-</sup> CD137L<sup>+</sup>  $\gamma\delta$  T cells in the PD and HD groups. Contrarily, the absolute frequency of CD137<sup>+</sup> CD137L<sup>-</sup>  $\gamma\delta$  T cells in the PD and HD groups is significantly increased, as well as the percentage in  $\gamma\delta$  T cells. The percentage in the  $\gamma\delta$  T cells of CD137<sup>-</sup> CD137L<sup>+</sup>  $\gamma\delta$  T cells cells is decreased in both patient groups, with a statistically significant difference in PD.

Figure 30 presents the comparison of the expression of CD25 by  $\gamma\delta$  T cell population in the different groups, as an absolute frequency and as percentage of  $\gamma\delta$  T cells.

## Results



**Figure 30.** Analysis of the absolute frequency (a) and as a percentage of total  $\gamma\delta$  T cells (b) of CD25<sup>+</sup>  $\gamma\delta$  T cells in the PD, HD and CTRL groups. One-way ANOVA test was used to compare the different groups. ns: not significant; \*, \*\*, \*\*\*: statistically significant (\* p<0.05, \*\* p<0.01 and \*\*\* p<0.001).

As seen in Figure 30, a statistically significant decrease is seen in the absolute frequency the percentage in the  $\gamma\delta$  T cells in CD25<sup>+</sup>  $\gamma\delta$  T cells in the PD and HD groups.

Figure 31 presents the comparison in the CD95/CD95L signaling by  $\gamma\delta$  T cells in the different groups, as an absolute frequency and as percentage of  $\gamma\delta$  T cells.

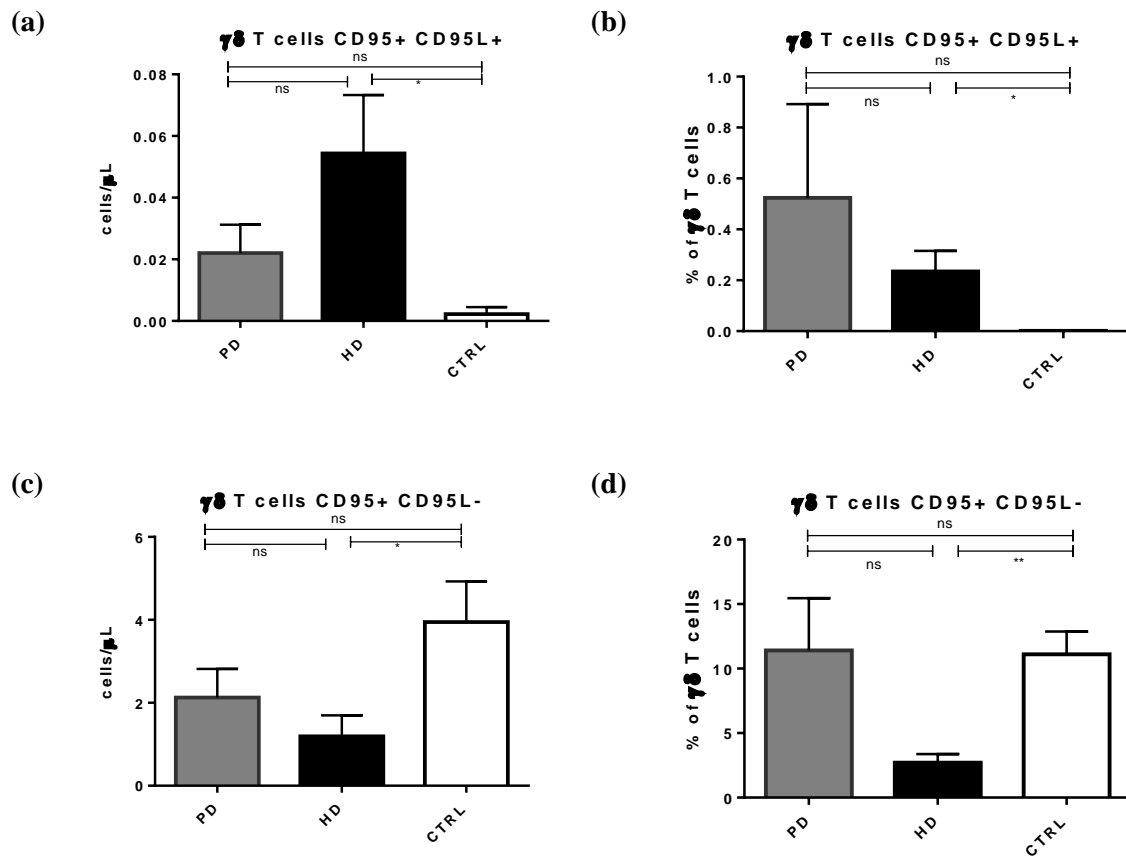

**Figure 31.** Analysis of the absolute frequency of CD95<sup>+</sup> CD95L<sup>+</sup>  $\gamma\delta$  T cells (a) and CD95<sup>+</sup> CD95L<sup>-</sup>  $\gamma\delta$  T cells (c); and CD95<sup>+</sup> CD95L<sup>+</sup>  $\gamma\delta$  T cells (b) and CD95<sup>+</sup> CD95L<sup>-</sup>  $\gamma\delta$  T cells (d) as a percentage of total  $\gamma\delta$  T cells in the PD, HD and CTRL groups. One-way ANOVA test was used to compare the different groups. ns: not significant; \*, \*\*, \*\*\*: statistically significant (\* p<0.05, \*\* p<0.01 and \*\*\* p<0.001).

Figure 31 shows that the absolute frequency and the percentage in the  $\gamma\delta$  T cells of CD95<sup>+</sup> CD95L<sup>+</sup>  $\gamma\delta$  T cells is significantly increased in HD. Contrarily, the absolute frequency and the percentage in the  $\gamma\delta$  T cells of CD95<sup>+</sup> CD95L<sup>-</sup>  $\gamma\delta$  T cells shows a significant decreased.

## 5 NK cell subsets

NK cells are a lymphocytic cell population characterized by the expression of CD56 and the absence of CD3, CD14 and CD19. NK cells can be classified into NK bright and NK<sup>Dim</sup>, with the first having a high expression of CD56 and lack of CD16 and the second having a lower expression of CD56 and high expression of CD16. NK cells express an array of surface receptors and cytokines, evaluated in this study.

Figure 32 presents the comparison of natural killer cells in the different groups, as an absolute frequency and as percentage of lymphocytes.

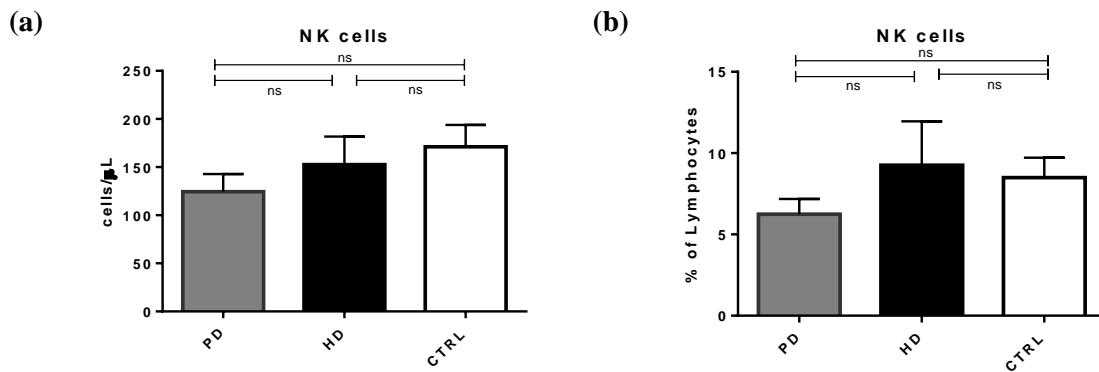

**Figure 32.** Analysis of the absolute frequency (a) and as a percentage of total lymphocytes (b) of NK cells in the PD, HD and CTRL groups. One-way ANOVA test was used to compare the different groups. ns: not significant; \*, \*\*, \*\*\*: statistically significant (\* p<0.05, \*\* p<0.01 and \*\*\* p<0.001).

Figure 32 presents the comparison of bright and dim natural killer cells in the different groups, as an absolute frequency and as percentage of NK cells.

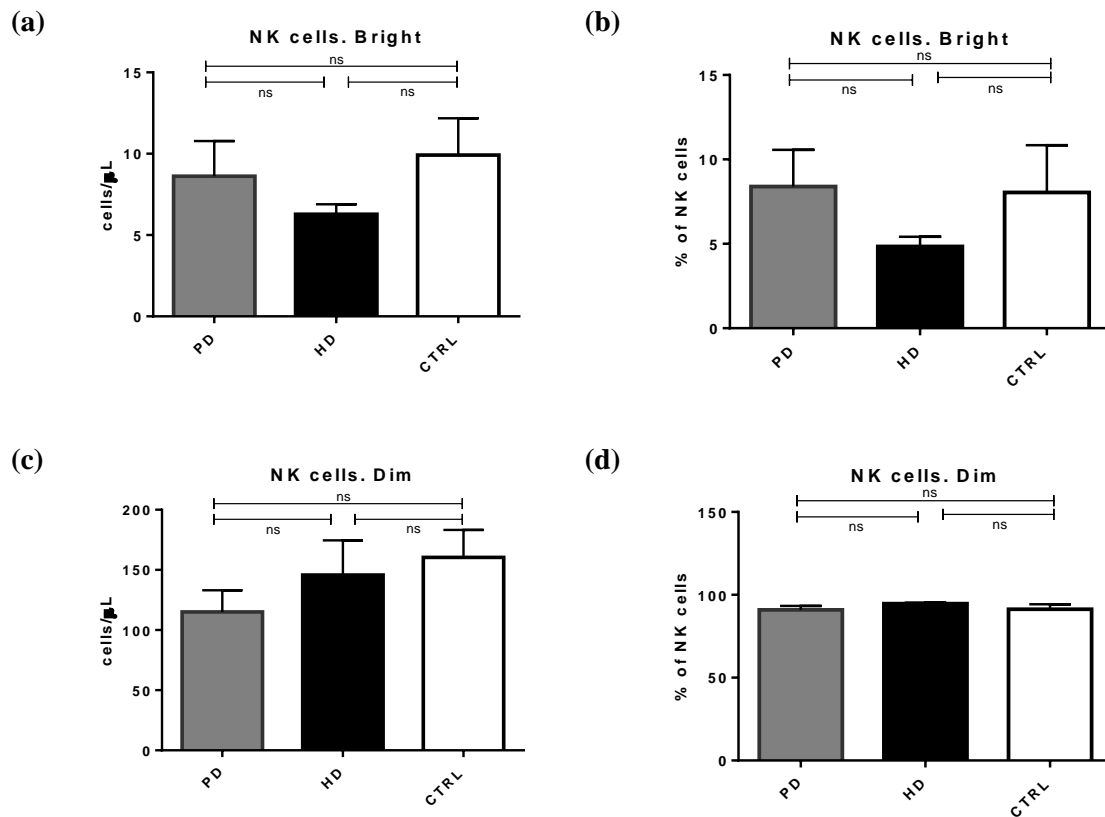
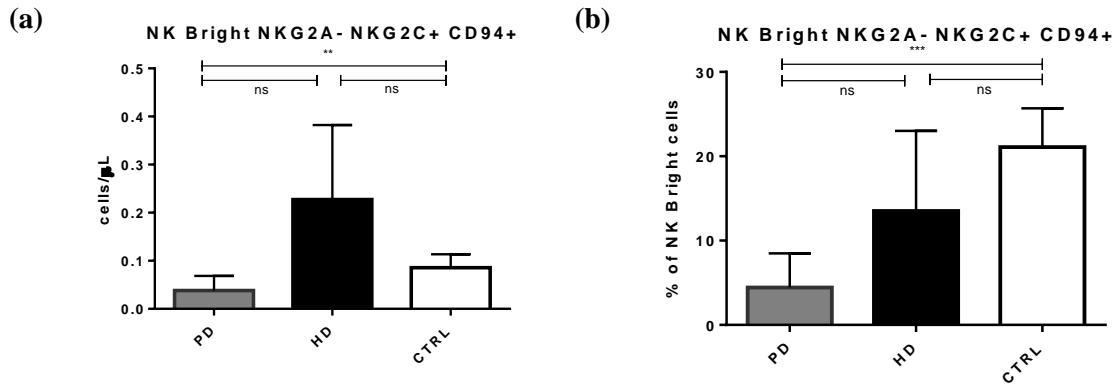

**Figure 33.** Analysis of the absolute frequency of NK<sup>Bright</sup> cells (a) and NK<sup>Dim</sup> cells (c); and NK<sup>Bright</sup> cells (b) and NK<sup>Dim</sup> cells (d) as a percentage of total NK cells in the PD, HD and CTRL groups. One-way ANOVA test was used to compare the different groups. ns: not significant; \*, \*\*, \*\*\*: statistically significant (\* p<0.05, \*\* p<0.01 and \*\*\* p<0.001).

Figure 32 and Figure 33 show no statistically significant difference in NK cells and bright and dim NK cells, as an absolute frequency and as a percentage of the parent population.

Figure 34 presents the comparison in the expression of CD94 by NKG2A<sup>-</sup> NKG2C<sup>+</sup> bright NK cells, as an absolute frequency and as percentage of bright NK cells.

## Results

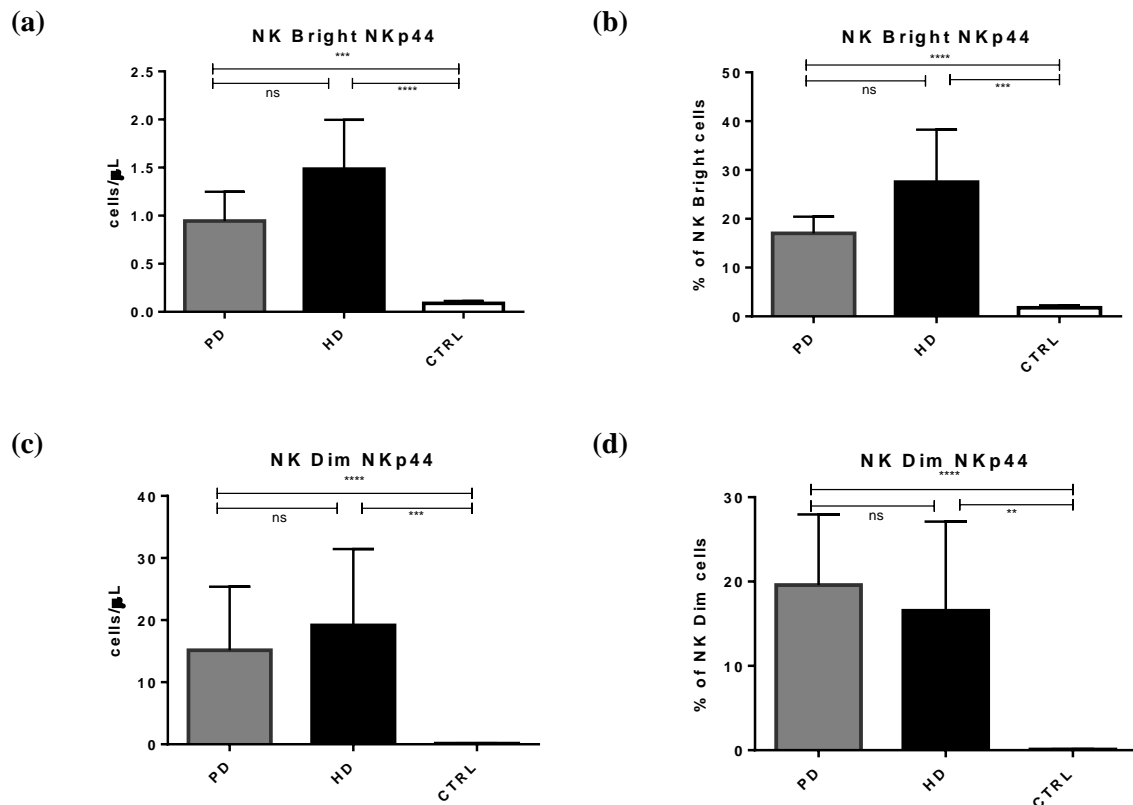

**Figure 34.** Analysis of the absolute frequency (a) and as a percentage of total NK<sup>Bright</sup> cells (b) of NKG2A<sup>-</sup>NKG2C<sup>+</sup>CD94<sup>+</sup> NK<sup>Bright</sup> cells in the PD, HD and CTRL groups. One-way ANOVA test was used to compare the different groups. ns: not significant; \*, \*\*, \*\*\*: statistically significant (\* p<0.05, \*\* p<0.01 and \*\*\* p<0.001).

Figure 34 shows that the absolute frequency of NKG2A<sup>-</sup> NKG2C<sup>+</sup> NK<sup>Bright</sup> cells that express CD94 is significantly higher in the HD group. However, as a percentage of bright NK cells, NKG2A<sup>-</sup>NKG2C<sup>+</sup>CD94<sup>+</sup> NK<sup>Bright</sup> cells are significantly diminished in PD.

Figure 35 presents the comparison in the expression of NKp44 by bright and dim NK cells, as an absolute frequency and as percentage of NK cells.



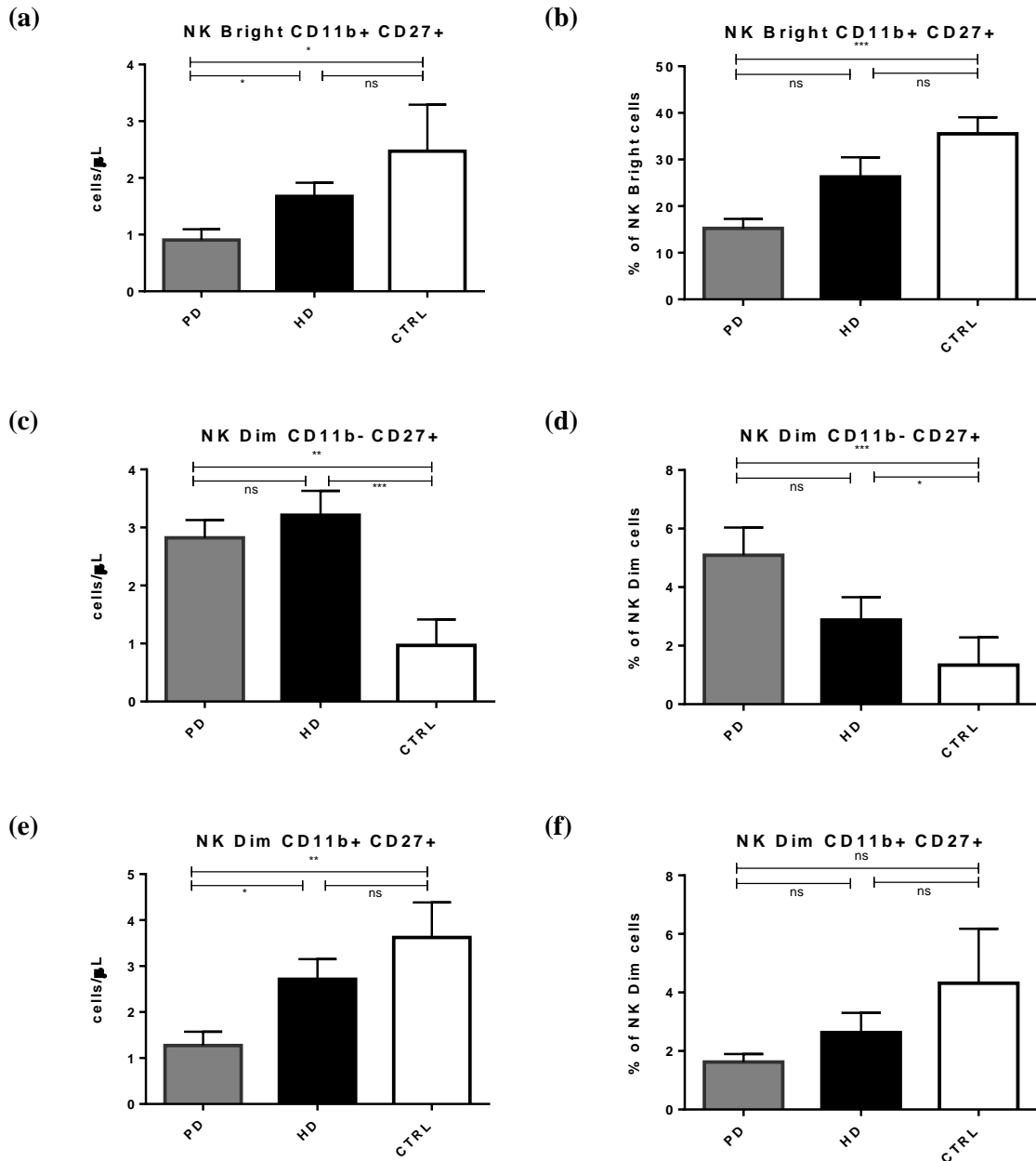

**Figure 35.** Analysis of the absolute frequency of NKp44 NK<sup>Bright</sup> cells (a) and NKp44 NK<sup>Dim</sup> cells (c); and NKp44 NK<sup>Bright</sup> cells as a percentage of NK<sup>Bright</sup> cells (b) and NKp44 NK<sup>Dim</sup> cells as a percentage of NK<sup>Dim</sup> cells (d) in the PD, HD and CTRL groups. One-way ANOVA test was used to compare the different groups. ns: not significant; \*, \*\*, \*\*\*: statistically significant (\* p<0.05, \*\* p<0.01 and \*\*\* p<0.001).

As seen in Figure 35, the expression of NKp44 by bright and dim NK cells is increased in PD and HD. This difference is statistically significant in both absolute frequency and as a percentage of NK cells.

Figure 36 presents the comparison in the expression of CD11b and CD27 by bright and dim NK cells, as an absolute frequency and as percentage of NK cells.

## Results

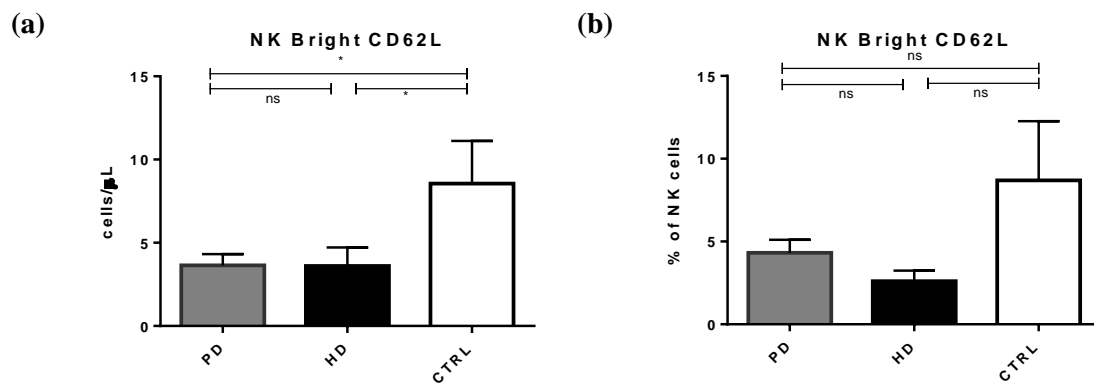

**Figure 36.** Analysis of the absolute frequency of CD11b<sup>+</sup> CD27<sup>+</sup> NK<sup>Bright</sup> cells (a), CD11b<sup>-</sup> CD27<sup>+</sup> NK<sup>Dim</sup> cells (c) and CD11b<sup>+</sup> CD27<sup>+</sup> NK<sup>Dim</sup> cells (e); and CD11b<sup>+</sup> CD27<sup>+</sup> NK<sup>Bright</sup> cells as a percentage of NK<sup>Bright</sup> cells (b), CD11b<sup>-</sup> CD27<sup>+</sup> NK<sup>Dim</sup> cells as a percentage of NK<sup>Dim</sup> cells (d) and CD11b<sup>+</sup> CD27<sup>+</sup> NK<sup>Dim</sup> cells as a percentage of NK<sup>Dim</sup> cells (f) in the PD, HD and CTRL groups. One-way ANOVA test was used to compare the different groups. ns: not significant; \*, \*\*, \*\*\*: statistically significant (\* p<0.05, \*\* p<0.01 and \*\*\* p<0.001).

The absolute frequency of CD11b<sup>+</sup> CD27<sup>+</sup> NK bright and dim is shown to be significantly decreased in both PD and HD groups. On the other hand, CD11b<sup>-</sup> CD27<sup>+</sup> NK<sup>Dim</sup> cells absolute frequency is significantly increased in PD and HD. As a

percentage of bright NK cells,  $CD11b^+ CD27^+ NK^{Bright}$  are significantly decreased in PD. As a percentage of dim NK cells,  $CD11b^- CD27^+ NK^{Dim}$  cells are significantly increased in both PD and HD groups.  $CD11b^+ CD27^+ NK^{Dim}$  show no differences in the percentage of dim NK cells (Figure 36).

Figure 37 presents the comparison in the expression of CD62L by bright NK cells, as an absolute frequency and as percentage of NK cells.

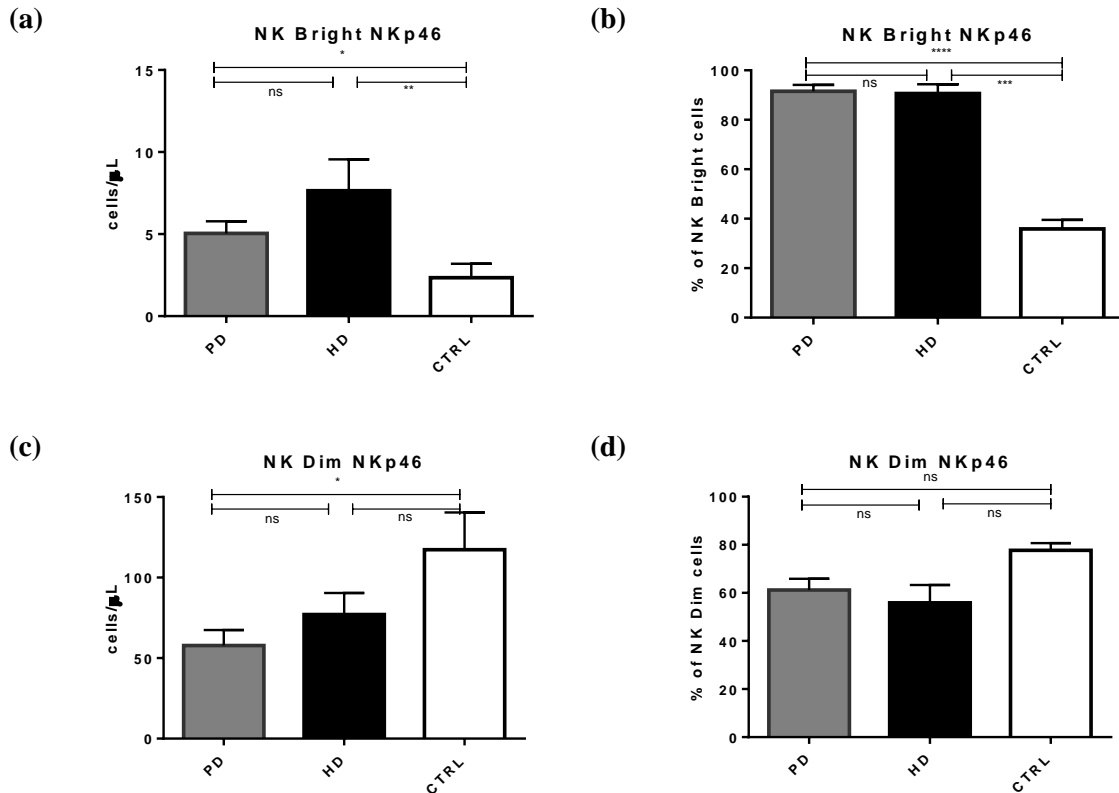

**Figure 37.** Analysis of the absolute frequency (a) and as a percentage of total NK cells (b) of CD62L<sup>Bright</sup> NK cells in the PD, HD and CTRL groups. One-way ANOVA test was used to compare the different groups. ns: not significant; \*, \*\*, \*\*\*: statistically significant (\*  $p < 0.05$ , \*\*  $p < 0.01$  and \*\*\*  $p < 0.001$ ).

Figure 37 shows a significant decrease in the absolute frequency of CD62L<sup>Bright</sup> NK cells in the PD and HD groups. CD62L<sup>Bright</sup> NK cells shown no significant differences in the percentage in NK cells.

Figure 38 presents the comparison in the expression of NKp46 by bright and dim NK cells, as an absolute frequency and as percentage of bright and dim NK cells.

## Results



**Figure 38.** Analysis of the absolute frequency of NKp46 NK<sup>Bright</sup> cells (a) and NKp46 NK<sup>Dim</sup> cells (c); and NKp46 NK<sup>Bright</sup> cells as a percentage of NK<sup>Bright</sup> cells (b) and NKp46 NK<sup>Dim</sup> cells as a percentage of NK<sup>Dim</sup> cells (d) in the PD, HD and CTRL groups. One-way ANOVA test was used to compare the different groups. ns: not significant; \*, \*\*, \*\*\*: statistically significant (\* p<0.05, \*\* p<0.01 and \*\*\* p<0.001).

Figure 38 shows an increase in the absolute frequency and as a percentage of bright NK cells of bright NK cells expressing NKp46 in the patient groups. This difference is significant in the PD group. The absolute frequency of NKp46 in dim NK cells is significantly decreased in PD. The expression of NKp46 by dim NK cells shows no statistically significant difference.

Figure 39 presents the comparison in the production of cytokines IFN- $\gamma$  and TNF- $\alpha$  by bright and dim NK cells, as an absolute frequency and as percentage of bright and dim NK cells.

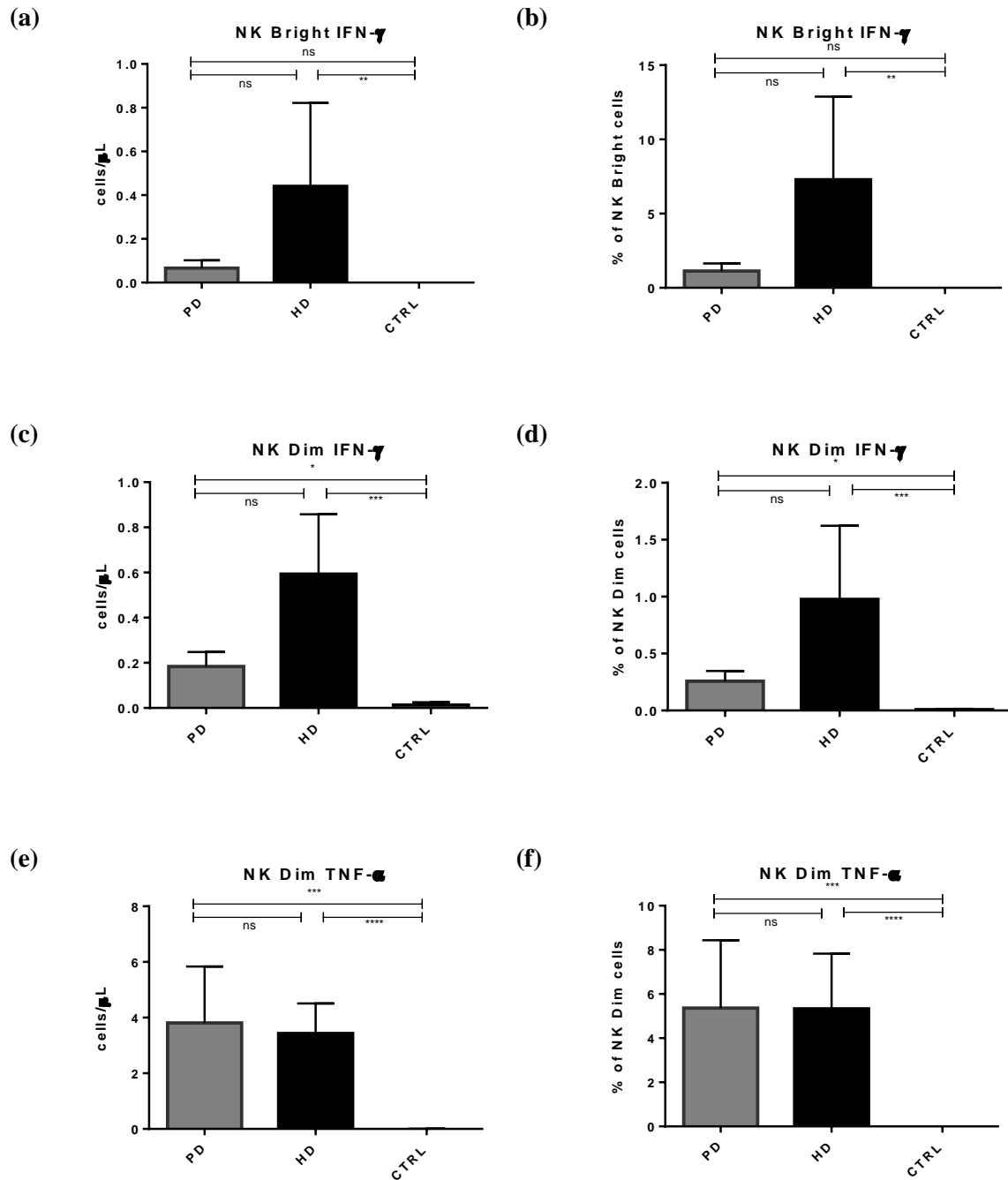

**Figure 39.** Analysis of the absolute frequency of IFN- $\gamma$ -expressing NK<sup>Bright</sup> cells (a), IFN- $\gamma$ -expressing NK<sup>Dim</sup> cells (c) and TNF- $\alpha$ -expressing NK<sup>Dim</sup> cells (e); and IFN- $\gamma$ -expressing NK<sup>Bright</sup> cells as a percentage of total NK<sup>Bright</sup> cells (b), IFN- $\gamma$ -expressing NK<sup>Dim</sup> cells as a percentage of total NK<sup>Dim</sup> cells (d) and TNF- $\alpha$ -expressing NK<sup>Dim</sup> cells as a percentage of total NK<sup>Dim</sup> cells (e) in the PD, HD and CTRL groups. One-way ANOVA test was used to compare the different groups. ns: not significant; \*, \*\*, \*\*\*: statistically significant (\* p<0.05, \*\* p<0.01 and \*\*\* p<0.001).

## Results

The absolute frequency and the percentage in bright NK cells of IFN- $\gamma$ -expressing bright NK cells are significantly increased in HD. The production of IFN- $\gamma$  and TNF- $\alpha$  by dim NK cells is significantly increased in both PD and HD groups (Figure 39).

## 6 Apoptosis and Necrosis detection

Apoptotic and necrotic cells were quantified using the Annexin V test. In apoptotic cells, the membrane phospholipid phosphatidylserine is translocated from the inner to the outer leaflet of the plasma membrane, exposing phosphatidylserine to the external cellular environment. Annexin V, conjugated with a fluorochrome, has high affinity for this molecule, binding to it and enabling the quantification of apoptotic cells. The necrotic process is accompanied by loss of membrane integrity. Viable cells with intact membranes exclude propidium iodide. However damaged cells are permeable to it. Therefore, the use of a vital dye such as propidium iodide enables the quantification of necrotic cells.

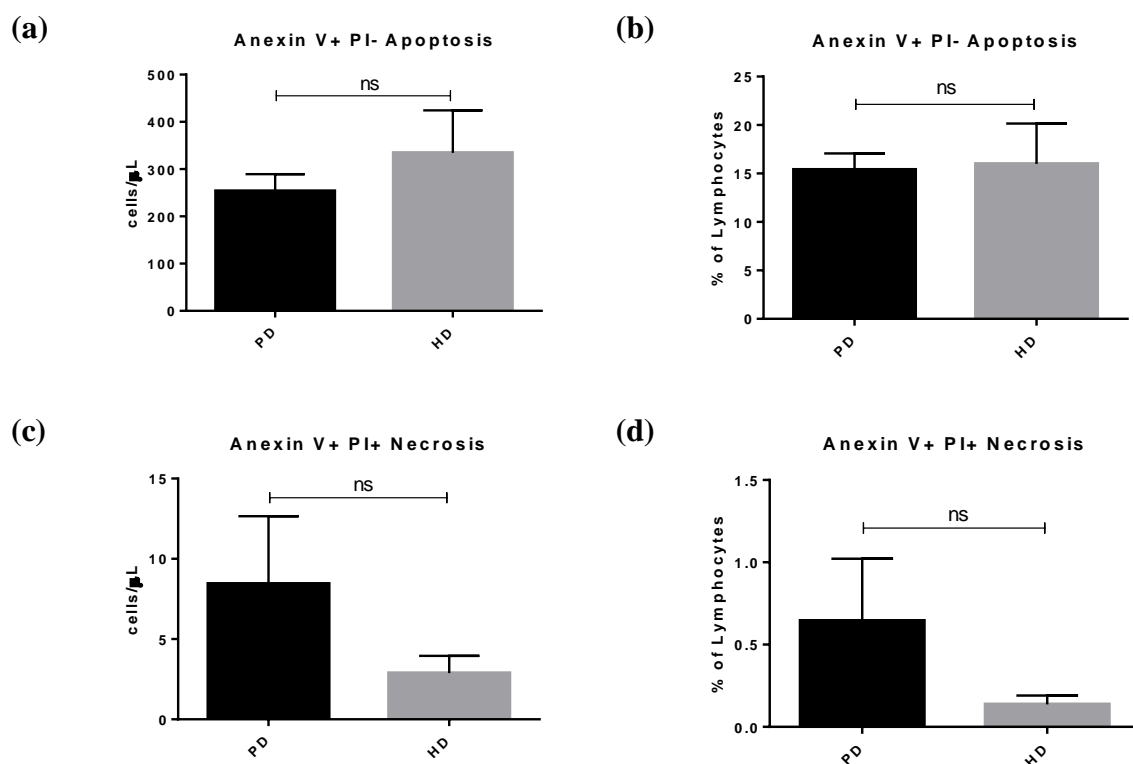

**Figure 40.** Analysis of the absolute frequency of apoptotic lymphocytes (a) and necrotic lymphocytes (c); and apoptotic lymphocytes (b) and necrotic lymphocytes (d) as a percentage of total lymphocytes of in the PD and HD groups. Non-parametric Mann-Whitney test was used to compare the different groups. . ns: not significant; \*, \*\*, \*\*\*: statistically significant (\*  $p < 0.05$ , \*\*  $p < 0.01$  and \*\*\*  $p < 0.001$ ).

## Results

Figure 40 shows no statistically significant difference in apoptotic and necrotic cells in the PD and HD groups.



## **VI Discussion**



Immune deficiency is one of the many consequences of chronic renal failure. It is accompanied by various immunologic abnormalities of innate and acquired immunity, such as immunodepression, that likely contributes to the high prevalence of infections among these patients as well as immunoactivation, resulting in inflammation (Betjes 2013; Griveas et al. 2005; Kato et al. 2008; Peraldi et al. 2009; Sharif et al. 2015).

The aim of this study was to elaborate a broad study of the alterations in the immune system in patients undergoing renal replacement therapies – peritoneal dialysis (PD) and hemodialysis (HD) – and whether these therapies have a different effect on the immune system. In order to do so, eleven HD samples, twenty one PD samples and twelve control samples were marked with fluorescent antibodies and analyzed by flow cytometry, in order to quantify several leukocytical populations.

## **1 B cells**

### **1.1 Decrease of immature B cells in PD and HD lead to an increased production of cytokines**

One of the analyzed populations, B cells, was shown to be decreased in the patients groups (Figure 9). This difference was particularly accentuated in *naïve* and *naïve* transitional populations. As suggested by Chung et al. 2003, Cuss et al. 2006 and Sims et al. 2011, transitional B cells are an immature populations of B cells with a diminished ability to proliferate and differentiate. Some studies indicate that these cells have a suppressive function, by inhibiting the production of IFN- $\gamma$  (Evans et al. 2007). The fact that the number of transitional B cells is diminished in HD and PD patients may indicate that their susceptibility to infection is greater (Figure 10). It is also observable in this figure that there is no statistically significant difference among therapies, indicating that there is no effect of the therapy in these parameters.

### **1.2 B cell response is impaired by the decrease of memory B cells in PD and HD**

Other B cell populations with altered numbers include memory B cells and memory B cell-derived plasmablasts (Figure 11). Memory B cells are characterized by

their longevity and their rapid and robust responses to antigen re-exposure. Once the organism comes in contact with a pathogen, memory B cells rapidly differentiate into plasmablast, capable of quickly clearing the infection (Kurosaki et al. 2015; Fink 2012). Once again, the reduced number of memory B cells and plasmablast may indicate that the response to infection in patients undergoing PD and HD is seriously impaired.

### **1.3 Alterations in the Fas/FasL signaling pathway increase susceptibility to infection in HD patients**

The expression of CD95 (Fas) and CD95L (Fas-L) is also altered in B cells (Figure 12). It is widely accepted that the Fas/FasL signaling in immune responses is connected to the induction of apoptosis. The Fas receptor may cause apoptosis in target cells, making it a target for pathogens to inhibit, in order to prolong their survival. On the other hand, FasL may be upregulated in infected cells, in order to facilitate the killing of responding immune cells (Hadji & Ceppi 2014; Chen et al. 2010; Peter & Krammer 2003; Dockrell 2003). Interestingly, Fas expressing B cells are higher in the control group, with a slight recuperation in the PD group, despite not being statistically significant. This may lead to the conclusion that the control group is the least susceptible to infection, while the PD is slightly less susceptible than the HD group. Concomitantly, the expression of FasL is higher in the HD group and lower in the PD group. Along with the decreased expression of Fas, the may indicate that B cells patients undergoing HD, may be more susceptible to infection.

## **2 T cells**

Another cell population studied was T lymphocytes. T lymphocytes can be divided into mostly T CD8 lymphocytes and T CD4 lymphocytes.

### **2.1 Switch from memory to effector T CD4 cells promotes inflammation**

From the T CD4 cell populations studied, the most acute differences were observed in the central memory, effector memory and effector populations (Figure 14).

The main role of T CD4 cells is to recruit other lymphoid cell populations into secondary lymphoid tissue or sites of pathogen infection, helping in expansion or function of other effector cells, or offering direct effector function through production of cytokines or cell-mediated cytotoxicity (Chaplin 2010).

Effector memory cells express homing receptors that facilitate migration to the site of inflammation and produce a variety of cytokines within several hours of stimulation. Central memory cells do not produce any of the effector cell lineage cytokines immediately after stimulation. However, they are able to migrate and proliferate extensively, acquiring effector functions and cytokine production later (Pepper & Jenkins 2012; Zaph et al. 2006).

From Figure 14, it is observable that central memory T CD4 cell numbers are elevated in the control group, while T CD4 cells with effector functions are depleted in this same group, in comparison with the PD and HD groups. This may lead to the conclusion that T CD4 cells have differentiated from memory to effector functions, resulting from an encounter with a foreign pathogen.

## **2.2 Decrease of Th1 and Th17 cells increases susceptibility to infection in PD and HD patients**

T CD4 cells can also be classified as Th1, Th2 and Th17. From these populations, it was observed that Th1 and Th17 were diminished in the PD and HD groups (Figure 16).

Th1 cells support cell-mediated immune responses, and are able to produce cytokines like IL-2 and IFN- $\gamma$ . These promote the activation of phagocytic cells, leading to the killing of the pathogen. Th2 cells, on the other hand, are more involved in allergic responses. TH17 cells are induced shortly after a pathogen is encountered, and help recruiting neutrophils that will eliminate these pathogens (Chaplin 2010).

The fact that the total numbers of these cell populations are diminished in both PD and HD groups suggests that their activating and recruiting are impaired, resulting in a greater susceptibility for infection.

### **2.3 Increased production of TGF- $\beta$ and IL-10 by regulatory T cells in PD and HD.**

Another sub-population of T CD4 cells are regulatory T cells (Treg). These cells are characterized by surface expression of the CD4 and CD25 antigens and by nuclear expression of the forkhead box protein 3 (Foxp3) transcription factor, essential for their development. They play an important regulatory role by down modulating immune responses. Most of this population's regulatory activity is exerted through the secretion of immunomodulatory cytokines, like TGF- $\beta$  and IL-10 (Chaplin 2010; Bacchetta et al. 2007).

This study shows that the total number of Treg cells is reduced in PD and HD groups (Figure 17). However, the existing Tregs cells are shown to have a greatly increased expression of TGF- $\beta$  and IL-10, particularly in patients undergoing HD (Figure 18). These results lead to the conclusion that the regulatory function in these patients is diminished and, in order to compensate, Treg cells increase the expression of cytokines.

### **2.4 Reduced T CD8 central memory cells in PD and HD indicate a differentiation into effector function in response to a pathogen.**

As mentioned before, few alterations were observed in T CD8 cells, with only a decrease in central memory T CD8 cells being observable in patients undergoing PD and HD (Figure 20). Like T CD4 cells, T CD8 central memory cells have the ability to differentiate into T CD8 cells with effector functions (Bannard et al. 2009; Obar & Lefrançois 2011). As such, the decrease in this population indicates that these cells have differentiated into effector TCD8 cells in response to a pathogen.

## **3 Monocytes**

### **3.1 Decrease of monocytes and dendritic cells in HD suggests a debilitated immune response**

Monocytes are a part of the innate immune system. They are present in the bone marrow, blood and spleen, from where they can migrate to the site of the injury.

When monocytes migrate from the circulation through the endothelium, they differentiate into macrophages or dendritic cells, which in turn respond to inflammation. However, monocytes themselves can be phagocytic and/or present antigen to T cells. Monocytes can be classified as classical and non-classical, depending on their expression of CD16. The classical monocytes, characterized as CD14<sup>+</sup> CD16<sup>+</sup>, are regarded as proinflammatory based on higher expression of proinflammatory cytokines and higher potency in antigen presentation (Ziegler-Heitbrock 2007; Shi & Pamer 2011; Sheel & Engwerda 2012; Murray & Wynn 2011).

Absolute frequency of monocytes was shown to be decreased in PD and HD groups, in comparison to the control population, with a slight recuperation in the PD population (Figure 21 and Figure 22). This may indicate that these patients, in particular those undergoing HD, have a debilitated immune response to a pathogen.

Dendritic cells are, as mentioned before, a cell population derived from monocytes. They are characterized by the absence of CD3, CD19, CD14 and CD20, and by the expression of HLA-DR. Dendritic cells can be classified into Myeloid or Plasmacytoid, depending on the expression of CD11c and CD123, respectively.

Dendritic cells bridge the innate and adaptive immune systems without directly engaging in effector activities such as pathogen killing. They are able to recognize pathogens using pattern recognition receptors, after which they migrate, to present pathogen-derived antigens to antigen-specific T cells. Dendritic cells can also upregulate co-stimulatory molecules and produce cytokines that drive T cell priming and effector differentiation. Plasmacytoid dendritic cells are specialized in sensing viral and bacterial pathogens, upon which they release cytokines in response to infection. Myeloid dendritic cells are responsible for capturing, processing and presenting antigens on their surface to T cells (Ganguly & Haak 2013; Chistiakov et al. 2015; Chistiakov et al. 2014).

As shown in Figure 24 and Figure 25, the total number of dendritic cells, as well as their plasmacytoid and myeloid populations, are heightened in the control group. A small recuperation in the PD group is also visible. These results may lead to the conclusion that patients with renal failure undergoing both renal replacement therapies

have difficulties in antigen presenting and effector differentiation in T cells, resulting from the lower numbers of dendritic cells.

#### **4 Invariant Natural Killer T cells and $\gamma\delta$ T cells**

##### **4.1 Alterations in the expression of several surface molecules by iNKT and $\gamma\delta$ T cells promoting inflammation**

Invariant natural killer T cells (iNKT) are a subset of T cells that recognize lipids presented by CD1b and, when activated, can catalyze an immune response. iNKT cells can perform this function by both direct cytotoxicity and cytokine production, activating other immune cells. These cells combine both classically innate and classically adaptive immunological features, making a bridge between these two types of immunity (Peukert et al. 2014; Pilonis et al. 2014).

iNKT cells produce several cytokines during infection, promoting the recruitment and activation of both innate and adaptive immune cell types, like macrophages, or B and T cells (Brennan et al. 2013).

Although their numbers were similar in the PD, HD and control groups, several surface molecules in these cells were shown to be altered in this study. For instance, iNKT cells expressing CD137L or CD62L were shown to be elevated in the PD and HD groups, in particular, the HD group (Figure 27).

CD62L, or L-selectin, acts as a "homing receptor" for lymphocytes to enter secondary lymphoid tissues. Molecules present on endothelial cells will bind to cells expressing CD62L, slowing their traffic through the blood, and facilitating entry into a secondary lymphoid organ (Frey et al. 1998).

CD137L is a surface molecule with cellular functions ranging from cell differentiation, proliferation, and survival to the production of inflammatory mediators in a variety of cells. However, their main role is in inflammation, namely by inducing cytokine production by macrophages (Kwon 2012; Kwon 2015).



These results, along with the previous information, leads to the conclusion that iNKT cells have been mobilized, in this case probably to the kidney, were they have a greater role in inflammation by inducing cytokine production by macrophages.

The expression of CD25 in iNKT was also evaluated (Figure 27), and was noted to be significantly higher in the control group. This may indicate that activated iNKT cells are much lower in the PD and HD groups.

$\gamma\delta$  T are a subset of T lymphocytes, characterized by expressing neither CD4 nor CD8, and by do not requiring conventional antigen presentation via MHC class molecules.

$\gamma\delta$  T cells are able of secreting cytokines and chemokines, which influence recruitment of other immune cells at the site of inflammation, and modulate the function of other innate and adaptive immune cells (Gao & Williams 2015; Gogoi & Chiplunkar 2013; Paul et al. 2014).

The study of these cells has shown that  $\gamma\delta$  T cells expressing CD137L (Figure 29) and CD25 (Figure 30) are depleted in PD and HD samples. Contrarily to iNKT, the decreased expression of CD137L and CD25 may indicate that these cells are less active and their stimulatory function in phagocytic cells is impaired. However, it is also observable that the expression of CD137 is increased in these two groups, particularly in the HD group (Figure 29).

CD137 signaling, much like CD137L signaling, plays an important role in inflammation. It has been shown to have a cytolytic activity, promoting inflammation by producing IFN- $\gamma$  and TNF- $\alpha$  (Kwon 2012). The higher number of CD137 expressing cells may indicate that an inflammatory state is present in these patients. These high numbers may also explain the decreased number CD137L, as some studies suggest that the expression of CD137 may lead to the endocytosis of CD137L (Kwon 2015).

Fas and FasL expression was also shown to be altered in  $\gamma\delta$  T cells. As mentioned before, the Fas/FasL signaling in immune responses is connected to the induction of apoptosis.

Figure 31 shows that  $\gamma\delta$  T cells expressing both CD95 and CD95L are greatly elevated in PD and particularly in HD populations. The presence of both molecules would normally lead to apoptosis. However, Fas is a target for inhibition by pathogens, because of their apoptotic functions. As a result, infected cells would have a greater expression of Fas (inhibited) and FasL (upregulated in infected cells), leading to the conclusion that PD and especially HD patients are more prone to infection. These results are in concurrence with  $\gamma\delta$  T cells expressing only CD95 being diminished in the PD and HD groups, making these cells more susceptible to infection.

## **5 Natural Killer cells**

### **5.1 Differences in the expression of NK receptors lead to the production of IFN- $\gamma$ and TNF- $\alpha$ in the HD group.**

Natural Killer (NK) cells are lymphocytic cells belonging to the innate immune system, and do not require pre-stimulation to perform their effector functions.

NK cells can be classified into two subsets, depending on their immunophenotype and function: CD56<sup>Dim</sup> and CD56<sup>Bright</sup>. CD56<sup>Dim</sup> constitutes approximately 90% of the total NK cell population in peripheral blood, approximately 10% of NK cells belong to the CD56<sup>Bright</sup> subset. Functionally, CD56<sup>Dim</sup> NK cells have high cytotoxic activity, CD56<sup>Bright</sup> NK cells are mostly involved in the production of cytokines.

NK cells express an array of inhibitory and activating receptors that engage MHC class I molecules, MHC class I-like molecules, and molecules unrelated to MHC, some of which were evaluated in this study (Chaplin 2010; Mandal & Viswanathan 2011).

These receptors include the C-type lectin-like receptors, CD94/NKG2. CD94/NKG2 receptors are expressed on most NK cells and a subset of T CD8 cells. NKG2A has two immunoreceptor tyrosine-based inhibitory motifs in its cytoplasmic domains and forms an inhibitory receptor when complexed with CD94. NKG2C has positively charged residues within its transmembrane regions and, when forming a heterodimer with CD94 with the help of the adapter molecule DAP12, acts as an

activating receptor. CD94/NKG2A is believed to prevent NK cell-mediated reactivity against normal cells, while CD94/NKG2C is believed to trigger effector functions when the control exerted by inhibitory receptors is overcome (Gumá et al. 2005; Wada et al. 2004).

NK<sup>Bright</sup> NKG2C<sup>+</sup>CD94<sup>+</sup> have been shown to be increased in patients undergoing HD, by comparison with the PD and control groups (Figure 34). This is a clear indication that cytokine producing NK cells are more activated in patients undergoing HD, possibly leading to a greater production of cytokines.

NK cells, both bright and dim, expressing NKp44 are also greatly diminished in the control group, and particularly elevated in the HD group (Figure 35).

NKp44 is an activating receptor, which associates with a dimer of the adaptor DAP12 to initiate signal transduction, resulting in production of cytotoxic agents, TNF- $\alpha$  and IFN- $\gamma$ . NKp44 is not normally expressed on NK cells, but is induced after NK cell activation (Horton & Mathew 2015; Rajagopalan & Long 2012; Vitale et al. 1998).

The elevated numbers of NKp44 expressing NK cells are concurrent with the previous results, and are indicative that NK cells are more activated in patients undergoing PD and especially HD, leading to a greater cytotoxic activity and production of cytokines.

The expression of CD11b and CD27 in NK cells enables the characterization of four distinct populations, with unique functional and phenotypic attributes. CD11b<sup>-</sup> CD27<sup>-</sup> NK cells display an immature phenotype and potential for differentiation; CD11b<sup>-</sup> CD27<sup>+</sup> and CD11b<sup>+</sup> CD27<sup>+</sup> NK cells show the best ability to secrete cytokines; and CD11b<sup>+</sup> CD27<sup>-</sup> NK cells exhibit high cytolytic function (Chiossone et al. 2009; Fu et al. 2011).

In this study, both CD11b<sup>+</sup> CD27<sup>+</sup> bright and dim NK cells in the PD and HD groups have been shown to be decreased, while CD11b<sup>-</sup> CD27<sup>+</sup> are greatly elevated (Figure 36). These results may be indicative of an inflammatory state, which would lead to an augmentation of a more immature subset of NK cells (CD11b<sup>-</sup> CD27<sup>+</sup>), and consequently a depletion of a more mature subset (CD11b<sup>+</sup> CD27<sup>+</sup>).

## Discussion

Figure 37 shows that CD62L expression in NK<sup>Bright</sup> cells is diminished in the HD and PD groups. As mentioned before, CD62L is an adhesion molecule, responsible for the homing of leukocytes during infection. It is also shown to be particularly expressed in resting NK<sup>Bright</sup> cells (Frey et al. 1998; Juelke et al. 2010). Furthermore, these results lead to the conclusion that the resting the resting population of NK<sup>Bright</sup> cells is lower in these patients, suggesting that NK<sup>Bright</sup> cells have been activated, possibly by a pathogen.

NKp46 is another activating NK receptor, member of the natural cytotoxicity receptor family. It is an important regulator of NK cell function, by increasing cytokine production and release of cytolytic granules, depending on the NK population (Freud et al. 2013; Romero et al. 2006).

Bright and dim NK cells expressing NKp46 have been evaluated in patients undergoing HD and PD (Figure 38). While the number of NK<sup>Dim</sup> cells expressing NKp46 is diminished in both populations in comparison to a control group, the number of NK<sup>Bright</sup> cells expressing NKp46 is elevated, particularly in the HD group. These leads to the conclusion that not only are the cells more activated, the NK<sup>Bright</sup> response is predominant over the NK<sup>Dim</sup> response, leading to a greater production of cytokines, concurrent with the previous results.

Finally, the actual production of the cytokines IFN- $\gamma$  and TNF- $\alpha$  was evaluated in the HD and PD populations. Figure 39 shows that the production of these cytokines is greatly elevated in patients undergoing HD and PD, with IFN- $\gamma$  being particularly elevated in both bright and dim NK cells of the HD group.

## **VII Conclusions and Future Perspectives**



The aim of this study was to evaluate the immunological differences in patients with chronic kidney disease undergoing peritoneal dialysis, hemodialysis and a control group, and whether these two renal replacement therapies have a distinct effect on the immune system. In order to do so, several cell populations were analyzed by flow cytometry, and their total and relative numbers were evaluated.

Analysis of B cell populations and surface molecules lead to a clear conclusion that patients undergoing HD and PD have a depleted immune system, and as a result are more susceptible, or already show signs of an inflammatory state. The reduced numbers of transitional and memory B cells along with the results of Fas and FasL expression lead in this direction. Although the analysis of these results clearly shows that patients in the HD and PD groups have a debilitated immune system, they are not elucidative on which of these therapies, if any, as a greater influence on the immune system.

The results T CD4 and T CD8 point in the same direction as the previous results. Although the main populations of T CD4 and T CD8 show no significant differences, the decrease of their memory populations and the augmentations of their effector population indicate the encounter of a pathogen may have already taken place. Once again, these results do not clearly indicate which therapy as a deeper impact on the immune system. However, the analysis of the results of regulatory T cells may be more elucidative on this matter. Although their total numbers are equally diminished on both populations, the production of TGF- $\beta$  and IL-10 by Treg cells is clearly more elevated in the HD group, although a significant difference was not observed. The elevated production of both of this cytokines is a clear indicator that the activity of these cells is exacerbated in this patients, which normally occurs in an inflammatory state.

The analyses of monocyte populations further support the previous statements. The total numbers of monocytes, particularly their classical population, show a decrease in The HD population concurrent with the previous findings. The analysis of the dendritic cell populations was not so elucidative on this matter, as dendritic cells, and their plasmacytoid and myeloid populations, were equally diminished in patients undergoing HD and PD.

iNKT and  $\gamma\delta$  T cells were then analyzed. The expression of CD137/CD137L and CD95/CD95L are particularly elucidative. The alterations in these pair receptors

previously discussed are in line with the hypothesis that patients undergoing HD and PD are more susceptible, or already show signs of an inflammatory state. These results become even more pertinent because they clearly suggest an aggravated state of inflammation in the HD group.

Finally, an analysis of NK populations and their activating and inhibitory receptors has been performed. In short, although their total numbers were not altered, the analysis of the state of maturation (CD27/CD11b) and the alterations in several receptors (CD94/NKG2; NKp44; NKp46) indicated that the cytokine-producing populations of NK cells were clearly favored in PD and especially HD. An even more incisive support for the proposed previously mentioned hypothesis came from the analysis of the expression of the cytokines IFN- $\gamma$  and TNF- $\alpha$  by NK cells, where there is a clearly exacerbated expression in the HD group.

In conclusion, these results clearly point in the direction that, on an immunological level, peritoneal dialysis might have a less severe effect on the immune system. However, due to the low number of available patients for study, these results may suffer some alterations. In fact, the low number of samples was one of the greatest obstacles in this study, namely during the statistical analysis.

Different studies in these samples would also give a broader image of the effect of these therapies. For instance, the quantification of several human cytokines, chemokines and growth factors using a Luminex® assay would give a more comprehensive analysis of the production of these molecules. A study on a genetic level, with the analysis of alterations in different RNAs, would also be an important step in understanding the differences in the effects of these two renal replacement therapies.



## **VIII References**



- Bacchetta, R., Gambineri, E. & Roncarolo, M.-G., 2007. Role of regulatory T cells and FOXP3 in human diseases. *The Journal of allergy and clinical immunology*, 120(2), pp.227–235.
- Bannard, O., Kraman, M. & Fearon, D., 2009. Pathways of memory CD8+ T-cell development. *European journal of immunology*, 39(8), pp.2083–2087.
- Bende, R.J., Van Maldegem, F. & Van Noesel, C.J.M., 2009. Chronic inflammatory disease, lymphoid tissue neogenesis and extranodal marginal zone B-cell lymphomas. *Haematologica*, 94(8), pp.1109–1123.
- Betjes, M.G.H., 2013. Immune cell dysfunction and inflammation in end-stage renal disease. *Nature reviews. Nephrology*, 9(5), pp.255–65..
- Beutler, B., 2004. Innate immunity: An overview. *Molecular Immunology*, 40(12), pp.845–859.
- Bewick, S., Yang, R. & Zhang, M., 2009. The danger is growing! a new paradigm for immune system activation and peripheral tolerance. *PLoS ONE*, 4(12).
- Bianchi, M.E., 2007. DAMPs, PAMPs and alarmins: all we need to know about danger. *Journal of leukocyte biology*, 81(1), pp.1–5.
- Brennan, P.J., Brigl, M. & Brenner, M.B., 2013. Invariant natural killer T cells: an innate activation scheme linked to diverse effector functions. *Nature reviews. Immunology*, 13(2), pp.101–17.
- Carsetti, R., 2000. The development of B cells in the bone marrow is controlled by the balance between cell-autonomous mechanisms and signals from the microenvironment. *The Journal of experimental medicine*, 191(1), pp.5–8.
- Chaplin, D.D., 2010. Overview of the immune response. *Journal of Allergy and Clinical Immunology*, 125(2 SUPPL. 2), pp.S3–S23.
- Chen, L. et al., 2010. CD95 promotes tumour growth. *Nature*, 465(7297), pp.492–496.
- Chiossone, L. et al., 2009. Maturation of mouse NK cells is a 4-stage developmental program. *Blood*, 113(22), pp.5488–5496.
- Chistiakov, D. a. et al., 2015. Myeloid dendritic cells: Development, functions, and role in atherosclerotic inflammation. *Immunobiology*, 220(6), pp.833–844.
- Chistiakov, D. a. et al., 2014. Plasmacytoid dendritic cells: development, functions, and role in atherosclerotic inflammation. *Frontiers in Physiology*, 5(July), pp.1–17.
- Chung, J.B., Silverman, M. & Monroe, J.G., 2003. Transitional B cells: Step by step towards immune competence. *Trends in Immunology*, 24(6), pp.342–348.
- Cohen, G. & Hörl, W.H., 2012. Immune dysfunction in Uremia-An update. *Toxins*, 4(11), pp.962–990.

## References

- Cooper, M.D. & Alder, M.N., 2006. The evolution of adaptive immune systems. *Cell*, 124(4), pp.815–822.
- Cuss, A.K. et al., 2006. Expansion of functionally immature transitional B cells is associated with human-immunodeficient states characterized by impaired humoral immunity. *Journal of immunology (Baltimore, Md. : 1950)*, 176(3), pp.1506–1516.
- Dockrell, D.H., 2003. The multiple roles of Fas ligand in the pathogenesis of infectious diseases. *Clinical Microbiology and Infection*, 9(8), pp.766–779.
- Dranoff, G., 2004. Cytokines in cancer pathogenesis and cancer therapy. *Nature reviews. Cancer*, 4(1), pp.11–22.
- Evans, J.G. et al., 2007. Novel suppressive function of transitional 2 B cells in experimental arthritis. *Journal of immunology (Baltimore, Md. : 1950)*, 178(12), pp.7868–7878.
- Fink, K., 2012. Origin and function of circulating plasmablasts during acute viral infections. *Frontiers in Immunology*, 3(APR), pp.1–5.
- Finlay, B.B. & McFadden, G., 2006. Anti-immunology: Evasion of the host immune system by bacterial and viral pathogens. *Cell*, 124(4), pp.767–782.
- Freud, A.G. et al., 2013. Expression of the activating receptor, nkp46 (cd335), in human natural killer and t-cell neoplasia. *American Journal of Clinical Pathology*, 140(6), pp.853–866.
- Frey, M. et al., 1998. Differential expression and function of L-selectin on CD56bright and CD56dim natural killer cell subsets. *Journal of immunology (Baltimore, Md. : 1950)*, 161(1), pp.400–408.
- Fu, B. et al., 2011. CD11b and CD27 reflect distinct population and functional specialization in human natural killer cells. *Immunology*, 133(3), pp.350–359.
- Ganguly, D. & Haak, S., 2013. The role of dendritic cells in autoimmunity. *Nature Reviews Immunology*, 13(8), pp.566–577.
- Gao, Y. & Williams, A.P., 2015. Role of Innate T Cells in Anti-Bacterial Immunity. *Frontiers in Immunology*, 6(June).
- Germain, R.N., 2002. T-cell development and the CD4-CD8 lineage decision. *Nature reviews. Immunology*, 2(5), pp.309–322.
- Gogoi, D. & Chiplunkar, S. V, 2013. Targeting gamma delta T cells for cancer immunotherapy : bench to bedside. *Indian J. Med. Res.*, 138(November), pp.755–761.
- Golden-Mason, L. & Rosen, H.R., 2013. Natural Killer cells: Multi-faceted players with key roles in Hepatitis C immunity. *Immunology Rev.*, 255(1), pp.68–81.

- Griveas, I. et al., 2005. Comparative analysis of immunophenotypic abnormalities in cellular immunity of uremic patients undergoing either hemodialysis or continuous ambulatory peritoneal dialysis. *Renal failure*, 27(3), pp.279–282.
- Gumá, M. et al., 2005. The CD94/NKG2C killer lectin-like receptor constitutes an alternative activation pathway for a subset of CD8+ T cells. *European Journal of Immunology*, 35(7), pp.2071–2080.
- Den Haan, J.M.M., Arens, R. & van Zelm, M.C., 2014. The activation of the adaptive immune system: Cross-talk between antigen-presenting cells, T cells and B cells. *Immunology Letters*, 162(2), pp.103–112.
- Hadji, A. & Ceppi, P., 2014. Death Induced by CD95 or CD95 Ligand Elimination. *Cell Rep.*, 7(1), pp.209–222.
- Hatton, R.D., 2011. TGF- $\beta$  in Th17 cell development: the truth is out there. *Immunity*, 34(3), pp.288–290.
- Hauser, A.B. et al., 2008. Characteristics and causes of immune dysfunction related to uremia and dialysis. *Peritoneal Dialysis International*, 28(SUPP. 3), pp.183–187.
- Horton, N.C. & Mathew, P. a., 2015. Nkp44 and Natural Cytotoxicity Receptors as Damage-Associated Molecular Pattern Recognition Receptors. *Frontiers in Immunology*, 6(February), pp.1–6.
- Juelke, K. et al., 2010. CD62L expression identifies a unique subset of polyfunctional CD56 dim NK cells. *Blood*, 116(8), pp.1299–1307.
- Kaech, S.M. et al., 2002. Molecular and functional profiling of memory CD8 T cell differentiation. *Cell*, 111, pp.837–851.
- Kato, S. et al., 2008. Aspects of immune dysfunction in end-stage renal disease. *Clinical journal of the American Society of Nephrology : CJASN*, 3(5), pp.1526–1533.
- Kurosaki, T., Kometani, K. & Ise, W., 2015. Memory B cells. *Nature Reviews Immunology*, 11, pp.1–11.
- Kurts, C. et al., 2013. The immune system and kidney disease: basic concepts and clinical implications. *Nature reviews. Immunology*, 13(10), pp.738–53.
- Kwon, B., 2015. Is CD137 Ligand ( CD137L ) Signaling a Fine Tuner of Immune Responses ? , 15(3), pp.121–124.
- Kwon, B., 2012. Regulation of Inflammation by Bidirectional Signaling through CD137 and Its Ligand. *Immune network*, 12(5), pp.176–80.
- Ma, C.S. et al., 2012. The origins, function, and regulation of T follicular helper cells. *Journal of Experimental Medicine*, 209(7), pp.1241–1253.

## References

- Mandal, A. & Viswanathan, C., 2011. Natural killer T cells in health and disease. *Frontiers in bioscience (scholar edition)*, 3(2), pp.236–251.
- Mathern, D.R. & Heeger, P.S., 2015. Molecules Great and Small: The Complement System. *Clinical Journal of the American Society of Nephrology*.
- Misra, M., 2008. Basic mechanisms governing solute and fluid transport in hemodialysis. *Hemodialysis International*, 12(SUPPL. 2), pp.25–28.
- Moretta, L. et al., 2004. Different checkpoints in human NK-cell activation. *Trends in Immunology*, 25(12), pp.670–676.
- Murray, P.J. & Wynn, T. a., 2011. Protective and pathogenic functions of macrophage subsets. *Nature Reviews Immunology*, 11(11), pp.723–737.
- Obar, J.J. & Lefrançois, L., 2011. Memory CD8+ T cell differentiation. *Ann N Y Acad Sci.*, pp.251–266.
- Parkin, J. & Cohen, B., 2001. An overview of the immune system. *Lancet*, 357(9270), pp.1777–1789.
- Paul, S., Shilpi & Lal, G., 2014. Role of gamma-delta (  $\gamma$  ) T cells in autoimmunity. *Journal of Leukocyte Biology*, 97(2), pp.259–271.
- Paul, W.E., 2010. What determines Th2 differentiation, in vitro and in vivo? *Immunology and cell biology*, 88(3), pp.236–239.
- Pel, M.J.C. & Pieterse, C.M.J., 2012. Microbial recognition and evasion of host immunity. *Journal of Experimental Botany*, 63(2), pp.695–709.
- Pepper, M. & Jenkins, M.K., 2012. Origins of CD4+ effector and central memory T cells. *Nature immunology*, 29(6), pp.997–1003.
- Peraldi, M.-N. et al., 2009. Oxidative stress mediates a reduced expression of the activating receptor NKG2D in NK cells from end-stage renal disease patients. *Journal of immunology (Baltimore, Md. : 1950)*, 182(3), pp.1696–1705.
- Peter, M.E. & Krammer, P.H., 2003. The CD95(APO-1/Fas) DISC and beyond. *Cell death and differentiation*, 10(1), pp.26–35.
- Peukert, K. et al., 2014. Invariant natural killer T cells are depleted in renal impairment and recover after kidney transplantation. *Nephrology Dialysis Transplantation*, 29(5), pp.1020–1028.
- Pilonis, K.A. et al., 2014. Invariant natural killer T cells regulate anti-tumor immunity by controlling the population of dendritic cells in tumor and draining lymph nodes. *Journal for ImmunoTherapy of Cancer*, pp.1–13.
- Rajagopalan, S. & Long, E.O., 2012. Found: a cellular activating ligand for NKp44. *Blood*, 122(17), pp.1795–1796.

- Ricklin, D., 2011. Complement - a key system for immune surveillance and homeostasis. *Nature immunology*, 11(9), pp.785–797.
- Romero, A.I. et al., 2006. NKp46 and NKG2D receptor expression in NK cells with CD56dim and CD56bright phenotype: Regulation by histamine and reactive oxygen species. *British Journal of Haematology*, 132(1), pp.91–98.
- Sarma, J.V. & Ward, P. a, 2012. The Complement System. *cell Tissue Res.*, 343(343(1)), pp.227–235.
- Saxena, R., 2005. Peritoneal dialysis: a viable renal replacement therapy option. *The American journal of the medical sciences*, 330(1), pp.36–47.
- Saxena, R. & West, C., 2006. Peritoneal dialysis: a primary care perspective. *Journal of the American Board of Family Medicine : JABFM*, 19(4), pp.380–9.
- Sharif, M.R. et al., 2015. Immune Disorders in Hemodialysis Patients Review. *Iranian Journal of Kidney Diseases*, 9(2), pp.84–96.
- Sheel, M. & Engwerda, C.R., 2012. The diverse roles of monocytes in inflammation caused by protozoan parasitic diseases. *Trends in Parasitology*, 28(10), pp.408–416.
- Shi, C. & Pamer, E.G., 2011. Monocyte recruitment during infection and inflammation. *Nature Reviews Immunology*, 11(11), pp.762–774.
- Sims, G.P. et al., 2011. Identification and characterization of circulating human transitional B cells Identification and characterization of circulating human transitional B cells. *Review Literature And Arts Of The Americas*, 105(11), pp.4390–4398.
- Vacher-Coponat, H. et al., 2008. Natural killer cell alterations correlate with loss of renal function and dialysis duration in uraemic patients. *Nephrology Dialysis Transplantation*, 23(4), pp.1406–1414.
- Vitale, M. et al., 1998. NKp44, a novel triggering surface molecule specifically expressed by activated natural killer cells, is involved in non-major histocompatibility complex-restricted tumor cell lysis. *The Journal of experimental medicine*, 187(12), pp.2065–2072.
- Vivier, E. et al., 2011. Innate or adaptive immunity? The example of natural killer cells. *Science*, 331(6013), pp.44–49.
- Wada, H. et al., 2004. The inhibitory NK cell receptor CD94/NKG2A and the activating receptor CD94/NKG2C bind the top of HLA-E through mostly shared but partly distinct sets of HLA-E residues. *European Journal of Immunology*, 34(1), pp.81–90.

## References

- Zaph, C. et al., 2006. Persistence and function of central and effector memory CD4+ T cells following infection with a gastrointestinal helminth. *Journal of immunology (Baltimore, Md. : 1950)*, 177(1), pp.511–518.
- Ziegler-Heitbrock, L., 2007. The CD14+ CD16+ blood monocytes: their role in infection and inflammation. *Journal of leukocyte biology*, 81(3), pp.584–592.