



UNIVERSIDADE D
COIMBRA

Joana Soraia Martinheira da Silva

TRAINEESHIP REPORT
INTERNSHIP IN LABORATORY CLINICAL GENETICS

VOLUME 1

Traineeship report conducted within the scope of the Master's degree in Laboratory Clinical Genetics, oriented by Prof. Dr. Domenico Coviello and Prof. Dr^a. Isabel Carreira, and presented to the Faculty of Medicine, University of Coimbra.

September 2022

ACKNOWLEDGEMENTS

The achievement of this work was only possible thanks to the collaboration and help of several people, to whom I would like to express my eternal gratitude.

To my supervisor, Professor Dr. Domenico Coviello, I would like to thank him for giving me the opportunity to do my internship in his laboratory and for welcoming me so well after my arrival in Italy, as well as for all his tireless support, encouragement, good disposition, scientific guidance and critical analysis of this work.

To my co-supervisor, Professor Dr. Isabel Marques Carreira, I would like to thank for the scientific guidance, support, availability and kindness.

To the whole team of the human genetics laboratory of the Giannina Gaslini institute, for the welcome, availability and sympathy demonstrated throughout my time there. In particular, I would like to thank Dr. Cristina Morerio and Dr. Elisa Tassano for their scientific guidance, support and helpfulness.

To my friend and fellow intern, Rute Pinto, for all the support, spirit of mutual help, friendship and conviviality.

To my family for always being present and supporting me in all the challenges and moments of my life.

To my friends, especially my best friend Bruna Soraia, for all the support, affection and friendship throughout all these years.

To all, once again, thank you.

INDICE

ACKNOWLEDGEMENTS.....	1
INDICE.....	3
LIST OF FIGURES.....	5
ABBREVIATIONS.....	7
RESUME.....	12
RESUMO.....	13
INTRODUCTION.....	14
1. Institute Giannina Gaslini.....	14
2. Laboratory of Human Genetics.....	14
PART 1 – TRAINEESHIP REPORT.....	16
1. History of Clinical Cytogenetics.....	17
2. Introduction to Conventional Cytogenetics.....	19
2.1. Chromosomes.....	19
2.2. DNA.....	22
2.3. Chromosomal Anomalies.....	22
3. Introduction to Molecular Cytogenetics.....	24
3.1. Fluorescence <i>In Situ</i> Hybridization.....	24
4. My Internship Experience in the Institute Giannina Gaslini.....	27
4.1. Laboratory of Postnatal and Hemato-oncological Cytogenetics.....	27
4.1.1. Methodology – Peripheral Blood Samples.....	31
4.1.1.1. Culture of Peripheral Blood Lymphocytes for Chromosome Analysis.....	31
4.1.2. Clinical Cases.....	40
4.1.3. Methodology – Bone Marrow Samples.....	58
4.1.3.1. Culture of Hematopoietic Cells from Bone Marrow and Peripheral Blood for Chromosome Analysis.....	59
4.1.4. Clinical Cases.....	64
4.2. Prenatal Screening and Diagnosis.....	70
4.2.1. Non-Invasive Prenatal Genetic Testing (NIPT).....	75

4.3. Case Report – Interstitial 2q24.2q24.3 Microdeletion: Two New Cases with Similar Clinical Features Except for Profound Deafness.....	77
PART 2 – TRAINEESHIP REPORT.....	81
MOLECULAR GENETICS.....	82
1. Next Generation Sequencing.....	82
2. Fragile X Syndrome.....	84
2.1. Phenotype.....	84
2.2. Classification of <i>FMRI</i> alleles.....	85
2.3. Mosaicism of FXS.....	86
2.4. Diagnosis of FXS.....	86
2.5. Clinical Case.....	88
3. Cystic Fibrosis.....	91
3.1. Phenotype.....	91
3.2. Classification of <i>CFTR</i> gene Mutations.....	91
3.3. Molecular Genetic Diagnosis of Cystic Fibrosis.....	92
3.4. Clinical Case.....	93
4. Hypertrophic Cardiomyopathy.....	96
4.1. Diagnosis of HCM.....	96
4.2. Clinical Case.....	97
5. Hemoglobinopathies.....	100
5.1. Thalassemias.....	100
5.1.1. Alpha-thalassemia.....	101
5.1.2. Beta-thalassemia.....	102
5.2. Diagnosis of Thalassemia.....	103
5.3. Clinical Case.....	105
CONCLUSION.....	109
REFERENCES.....	110

LIST OF FIGURES

Figure 1 – Logo of the Giannina Gaslini Institute

Figure 2 – Normal male karyotype.

Figure 3 – Flowchart from the arrival of the samples to the laboratory until the final report.

Figure 4 – Example of a worksheet used in postnatal cytogenetics and hemato-oncology.

Figure 5 – Peripheral blood samples after chromosome harvesting and before the hypotonic shock.

Figure 6 – Samples after chromosome fixation, ready to be spread.

Figure 7 – Preparation of all the materials and solutions necessary for the chromosome staining with the quinacrine mustard.

Figure 8 – Microscope and computer used in the postnatal cytogenetics laboratory.

Figure 9 – Example of a postnatal cytogenetics final report.

Figure 10 – Example of a postnatal FISH final report.

Figure 11 – Representation of the *SRY* Cytocell probe mix, where you can see the red probe covering the Yp11.31 region, the green probe for the heterochromatic region (Yq12) of the Y chromosome and the blue probe for the centromere of the X chromosome.

Figure 12 – João's karyotype metaphase.

Figure 13 – João's karyotype.

Figure 14 – Schematic representation of the human Y chromosome.

Figure 15 – Maria's karyotype metaphase.

Figure 16 – Maria's karyotype.

Figure 17 – Paula's karyotype metaphase.

Figure 18 – Paula's karyotype.

Figure 19 – Flowchart for the analysis of SMC cases.

Figure 20 – Pedro's karyotype metaphase.

Figure 21 – Pedro's karyotype.

Figure 22 – Tiago's karyotype.

Figure 23 – Tiago's FISH metaphase.

Figure 24 – Tiago’s FISH performed in nuclei in interphase.

Figure 25 – Example of a final karyotype report of hematopoietic cells derived from a bone marrow sample.

Figure 26 – Luisa’s bone marrow karyotype.

Figure 27 – Mariana’s bone marrow karyotype.

Figure 28 – Prenatal diagnosis sampling (amniocentesis and CVS).

Figure 29 – Flowchart of NIPT.

Figure 30 – Article cover “Interstitial 2q24.2q24.3 Microdeletion: Two New Cases with Similar Clinical Features with the Exception of Profound Deafness”.

Figure 31 – Results of the Array-CGH and FISH analysis. **A)** Array-CGH of patient 1. **B)** Array-CGH of patient 2. **C)** FISH confirmation of the microdeletion present in both patients.

Figure 32 – Genes present in 2q24.2q24.3 (chr2: 160,790,267 – 165,802,103) deleted in patients 1 and 2.

Figure 33 – Heredogram from the Ramos family (two generations).

Figure 34 – Heredogram representing the segregation of the *CFTR* gene variants from the parents to patient 1.

Figure 35 – Heredogram representing the segregation of the *CFTR* gene variants from the parents to patient 2.

Figure 36 – Ferreira family heredogram (4 generations).

Figure 37 – Results from the hemogram, sideremia and ferritin analysis, and HPLC’s results.

Figure 38 – Resulting HPLC chromatogram.

Figure 39 – Resulting HPLC chromatogram.

Figure 40 – Sequence of the DNA fragment referent to the *HBA2* gene showing a G>T variant, in the region indicated in this image.

ABBREVIATIONS

A – Adenine

ABL1 – Abelson murine leukemia

ACMG – American College of Medical Genetics

AFF1 – AF4/FMR2 Family, Member 1

ALL-Infant – Acute Lymphoblastic Leukemia-Infant

AP – Accelerated Phase

Array-CGH – Array-Comparative Genomic Hybridization

AZF – Azoospermia Factor

BCR – Breakpoint Cluster Region

BP – Blast Phase

C – Cytosine

CBC – Complete Blood Count

CCyR – Complete Cytogenetic Response

CEP – Chromosome Enumeration Probe

CEQAS – External Quality Assessment Service

CF – Cystic Fibrosis

cffDNA – cell-free fetal DNA

CFTR – Cystic Fibrosis Transmembrane Conductance Regulator

CML – Chronic Myeloid Leukemia

CNVs – Copy Number Variations

COBLL1 – COBL-Like Protein 1

CP – Chronic Phase

CPM – Confined Placental Mosaicism

CVS – Chorionic Villus Sampling

DAPI – 4',6-diamidino-2-phenylindole

dbSNP – Single Nucleotide Polymorphism Database

DNA – Deoxyribonucleic acid
DPP4 – Dipeptidyl Peptidase 4
ECA – European Cytogenetics Association
EMQN – European Molecular Genetics Quality Network
ETI – Elexacaftor/Tezacaftor/Ivacaftor
FAP - Fibroblast Activation Protein
FBS – Fetal Bovine Serum
FIGN - Fidgetin
FISH – Fluorescence *In Situ* Hybridization
FF – Fetal Fraction
FMRI – Fragile X Mental Retardation 1
FMRP – Fragile X Mental Retardation Protein
FXPOI – Fragile X-Associated Premature Ovarian Failure
FXS – Fragile X Syndrome
FXTAS – Fragile X-Associated Tremor/Ataxia Syndrome
G – Guanine
GCA - Granulocyte Colony-Stimulating Factor
GCG – Glucagon
GJB2 – Gap Junction Protein Beta 2
GRB14 – Growth Factor Receptor-Bound Protein 14
Hb – Hemoglobin
HbA1 – Hemoglobin Alpha 1
HBA1 – Hemoglobin Subunit Alpha 1
HbA2 – Hemoglobin Alpha 2
HBA2 – Hemoglobin Subunit Alpha 2
HBB – Hemoglobin Subunit Beta
Hb-Bart – Hemoglobin Barts
HbF – Hemoglobin Fetal

HbH – Hemoglobin H Disease

hCG – human Chorionic Gonadotropin

HCM – Hypertrophic Cardiomyopathy

HPLC – High-Performance Liquid Chromatography

HUGO – Human Genome Organization

i.e. – *id est*

IFIH1 – Interferon-Induced Helicase C Domain 1

ISCN – International System of Human Cytogenetics Nomenclature

ITGB6 – Integrin Beta 6

JPH2 – Junctophilin 2

KCl – Potassium Chloride

KCNH7 – Potassium Channel Voltage-Gated Subfamily H Member 7

LDB3 – LIM Domain-Binding 3

LV – Left Ventricle

MAP – Medically Assisted Procreation

Mb – Megabase

MCH – Mean Corpuscular Hb

MCV – Mean Corpuscular Volume

MLL – Lysine-specific Methyltransferase 2A

MLPA – Multiplex Ligation-Dependent Probe Amplification

mPCR – methylation-sensitive Polymerase Chain Reaction

MTX – Methotrexate

MYBPC3 – Myosin-Binding Protein C3

MYH7 – Myosin Heavy Chain 7

NGS – Next Generation Sequencing

NHS – National Health System

NIPT – Non-Invasive Prenatal Testing

OMIM – Online Mendelian Inheritance in Man

PAPP-A – Pregnancy-Associated Plasma Protein A

PBS – Phosphate Buffered Saline

PCR – Polymerase Chain Reaction

Ph - Philadelphia

PHA – Phytohemagglutinin

PLA2R1 – Phospholipase A2 Receptor 1

PSMD14 – Proteasome 26S Subunit, Non-ATPase 14

QF-PCR – Quantitative Fluorescent Polymerase Chain Reaction

RBCs – Red Blood Cells

RBM20 – RNA-Binding Motif Protein 20

RBMS1 – RNA-Binding Motif Protein Single Strand-Interacting 1

rpm – revolution per minute

RPMI 1640 Medium – Roswell Park Memorial Institute 1640 Medium

RP-PCR – Repeated Primed-Polymerase Chain Reaction

RPS4Y1 – Ribosomal Protein S4 Y-linked 1

SIGU – *Società Italiana Genetica Umana*

SITE – *Società Italiana Talassemie ed Emoglobinopatie*

SLC38A11 – Solute Carrier Family 38 Member 11

SLC4A10 – Solute Carrier Family 4 Member 10

SMC – Supernumerary Marker Chromosome

SRY – Sex-determining Region Y

SSC – Saline-Sodium Citrate

T – Thymine

TANK – TRAF Family Member-Associated NF κ B Activator

TBR1 – T-box Brain 1

TKI – Tyrosine Kinase Inhibitor

UV – Ultraviolet

VUS – Variant of Uncertain Significance

WBCs – White Blood Cells

WES – Whole-Exome Sequencing

WGS – Whole-Genome Sequencing

RESUME

The curricular internship was undertaken as part of the second and last year of the master's degree in Laboratory Clinical Genetics at the Faculty of Medicine of the University of Coimbra, with the aim, given its professional nature, to introduce me to the reality of work/research in the area of human genetics, being also an important tool for the consolidation of my knowledge and personal growth.

The internship took place at the Institute Giannina Gaslini in Genoa (Italy), more precisely, at the Human Genetics Laboratory. It lasted eleven months, beginning on October 4 of 2021, and ending on August 31 of 2022, by the orientation of Dr. Domenico Coviello.

The main objectives of the internship were: the observation and execution of different laboratory techniques; interpretation of results and preparation of clinical reports; the ability to discuss the clinical cases best study strategy according to the medical reference and understanding the reason why the tests performed were chosen; acquire and develop communication skills (oral and written) in the field of laboratory clinical genetics and preparation of the internship final report.

During the internship, I had the opportunity to learn about several techniques and their implementation in prenatal and postnatal cytogenetics, molecular cytogenetics, and molecular genetics, but also their application in different areas, from pediatric hematology, cardiology, intellectual deficit, short stature, among others. However, my internship was mostly focused on postnatal cytogenetics, where I was also given the possibility to participate in the publication of a scientific article.

Keywords: conventional cytogenetics; molecular cytogenetics; molecular genetics; pre-natal; post-natal.

RESUMO

O estágio curricular foi realizado como parte do segundo e último ano do mestrado em Genética Clínica Laboratorial na Faculdade de Medicina da Universidade de Coimbra, com o objetivo, dado o seu carácter profissional, de me introduzir na realidade do trabalho/investigação na área da genética humana, sendo também importante para a consolidação dos meus conhecimentos e crescimento pessoal.

O estágio decorreu no Instituto Giannina Gaslini em Génova (Itália), mais precisamente, no Laboratório de Genética Humana. Durou cerca de onze meses, com início a 4 de outubro de 2021, e conclusão a 31 de agosto de 2022, com a orientação do Dr. Domenico Coviello.

Os principais objetivos do estágio foram: a observação e execução de diferentes técnicas laboratoriais; interpretação de resultados e preparação de relatórios clínicos; capacidade de discutir a melhor estratégia de estudo dos casos clínicos de acordo com a sua referência médica, compreendendo a razão pela qual os testes realizados foram escolhidos; adquirir e desenvolver capacidades de comunicação (oral e escrita) no campo da genética clínica laboratorial e preparação do relatório final do estágio.

Durante o estágio tive a oportunidade de observar/executar várias técnicas e a sua aplicação na citogenética pré- e pós-natal, citogenética molecular e genética molecular, como também a sua aplicação nas diferentes áreas, desde a hematologia pediátrica, cardiologia, défice intelectual, baixa estatura, entre outras. No entanto, o meu estágio centrou-se principalmente na citogenética pós-natal, onde também me foi dada a possibilidade de participar na publicação de um artigo científico.

Palavras-chave: citogenética convencional; citogenética molecular; genética molecular; pré-natal; pós-natal.

INTRODUCTION

1. Institute Giannina Gaslini

The Giannina Gaslini Institute is a scientific institute and pediatric hospital. It is the national reference point for complex neonatal, pediatric, and adolescent diseases. It was founded by the will of senator Gerolamo Gaslini, in 1931.

It consists of 20 pavilions, on over 73,000 square metres, arranged on a hill sloping down to the sea. More than half of the patients come from all regions of Italy. Every year, around 5% come from abroad, since it is Italy's only institution that has all medical and surgical specialities in the maternal and pediatric areas.

Research is a strategic objective of the institute. The integration between care, research, teaching, and continuous training, is very important to ensure quality and excellent care services.



ISTITUTO GIANNINA GASLINI
ISTITUTO PEDIATRICO
DI RICOVERO E CURA
A CARATTERE SCIENTIFICO

Figure 1 – Logo of the Giannina Gaslini Institute

2. Laboratory of Human Genetics

The laboratory of human genetics has sections in 3 buildings within the Institute Giannina Gaslini. In building 3, molecular genetics and prenatal cytogenetics are carried out, in building 15 is located postnatal cytogenetics and molecular cytogenetics, and last, in building 16 is the section of hemato-oncology cytogenetics.

The laboratory of human genetics develops activities in the areas of conventional and molecular cytogenetics, molecular genetics, bioinformatics, biobanks and genetic counselling.

Within the national health system, the laboratory performs pre- and postnatal genetic and genomic studies. Its goals are to diagnose and evaluate the components of complex and oncological diseases and to diagnose rare genetic diseases. In addition, also performs genetic testing using modern equipment, for example, next-generation sequencing (NGS) technology, having access as well to the most recent softwares and databases.

The main activities developed by the laboratory are:

- Classical and molecular cytogenetics for the diagnosis of constitutional and acquired chromosomal abnormalities, and investigation of genomic rearrangements
- Molecular genetics for the diagnosis of numerous pathologies, including, cardiomyopathies, mediterranean fever, cystic fibrosis, achondroplasia, fragile X-syndrome, male fertility, etc.
- Diagnosis of thalassemia and screening of other hemoglobinopathies

The laboratory integrates a quality management system with external quality control activity by European Molecular Genetics Quality Network (EMQN), Cytogenomic External Quality Assessment Service (CEQAS) and national *Istituto Superiore di Sanità*. The quality management system has been certified by Bureau Veritas and the Italian Society of Human Genetics (SIGU) for the UNI EN ISO 9001: 2015 and SIGUCERT standards since 2008. The laboratory's activities are in accordance with European Regulation EU679/2016 on privacy.

P

ART 1 – TRAINEESHIP REPORT

1. History Of Clinical Cytogenetics

Chromosomes were discovered for the first time at the end of the nineteenth century by Walther Flemming (1882) who published the first illustrations of human chromosomes in corneal cells. Around the same time, Waldeyer (1888), introduced the word chromosome, a combination between the greek words *chrom* and *soma*, which means, coloured and body, respectively.

Over the next years, some separate investigators stated that the correct number of chromosomes present in human cells was 48, but only in 1956, did Joe Hin Tjio and Albert Levan, prove them all wrong with the report of the correct number of chromosomes (n=46) in cultured cells.

The year 1959 was called “the wonderful year of human cytogenetics” because were made very important discoveries: Leujene *et al.* (1959), described an extra chromosome on fibroblast cultures from patients with Down syndrome. This finding was later reported to involve one of the smallest pairs of chromosomes, eventually, being referred to as trisomy 21. According to Ford *et al.* (1959), females with Turner syndrome had 45 chromosomes apparently with a single X chromosome and no Y, whereas in accordance with Jacobs and Strong (1959) men with Klinefelter syndrome had 47 chromosomes, with an additional X chromosome.

In 1960 two syndromes were reported, such as trisomy 13 and 18, by Klaus Patau *et al.* (1960) and John Edwards *et al.* (1960) respectively. These conditions were recognized by their distinctive phenotype. Also, this year was identified the first somatic chromosome aberration, the Philadelphia chromosome in the peripheral blood cells of patients with chronic myeloid leukemia (Nowell & Hungerford, 1960). At the end of 1960, lymphocyte cultures made from samples of peripheral blood stimulated by phytohemagglutinin (PHA) were introduced, facilitating chromosome analysis.

Additionally, in 1960, a group of scientists collaborated to develop the ISCN (International System for Human Cytogenetic Nomenclature), an international writing technique for cytogenetic nomenclature. As a result, cytogeneticists can communicate cytogenetic results, such as chromosomal abnormalities, in a way that is understood everywhere around the world.

One of the most important milestones in the history of cytogenetics was the introduction of chromosome banding around the year 1970, by Caspersson, *et al.* (1970).

The chromosome bands helped identify deletions, duplications, inversions, and translocations, which had not been discovered before.

The history of cytogenetics has been marked by the discovery and use of new, more specific, and sensitive techniques and methods, which have allowed the detection of smaller chromosomal abnormalities associated with disease. Nowadays, chromosome analysis has much better resolution and precision at both cytological and genomic levels, being a huge important diagnostic procedure in numerous areas of medicine.

2. Introduction to Conventional Cytogenetics

Clinical cytogenetics is a field of genetics that studies chromosomes, their structure, function, heredity, and their role in human disease. Its main objective is the diagnosis of chromosomal abnormalities since chromosomal disorders make up a large class of genetic diseases, ranging from congenital malformations to mental retardation, among others. For example, specific chromosome abnormalities responsible for many syndromes are more frequent than all mendelian single-gene disorders. These can be found in about 1% of live births, 2% of pregnancies in women over the age of 35 years who undergo prenatal diagnosis and are the cause of nearly half of all spontaneous first-trimester abortions (Nussbaum, McInnes, Willard, & Hamosh, 2007).

2.1. Chromosomes

DNA, or deoxyribonucleic acid, is a molecule that contains the hereditary genetic information (genes) required for human development and function. This DNA molecule and its associated proteins, the histones, comprise the chromatin, the basic unit of the chromosomes (Gersen & Keagle, 2013).

Chromatin can be classified as euchromatin or heterochromatin. Euchromatin is less condensed, rich in genes and corresponds to regions of active transcription, while heterochromatin is normally highly condensed, poor in genes and silent transcription. It can be classified as constitutive or facultative. Constitutive heterochromatin is highly polymorphic, corresponds to highly repetitive DNA sequences and is generally located in the centromeric region of all chromosomes and at the distal end of the Y chromosome. Facultative heterochromatin, on the other hand, results from gene silencing mechanisms, such as the one that occurs during the random inactivation of one of the X chromosomes in women. These regions can be unzipped and become transcriptionally active again (Gardner & Amor, 2018), (Gersen & Keagle, 2013).

Chromosomes consist of two sister chromatids and a centromere, a constriction consisting of heterochromatin, where the two chromatids are joined together, dividing the chromosomes into two arms, q (longer) and p (shorter). The centromere can have 3 positions: metacentric (in the middle), submetacentric (off-centre) and acrocentric (close

to one end). Chromosomes are classified according to their size, centromere position and banding pattern (Nussbaum, McInnes, Willard, & Hamosh, 2007), (Gardner & Amor, 2018), (Gersen & Keagle, 2013).

The human genome is organized into 46 chromosomes that come in 23 matching pairs, one of each pair is inherited from the mother, while the other has a paternal origin. Of the 23 pairs of chromosomes, 22 are called autosomes and the last pair is called sex chromosomes. While the homologues of the autosomes have the same morphology in each sex, the homologues of the sexual chromosomes have different morphology, since they are responsible for sex determination: a female has a pair of X chromosomes, and the male has an X and a Y chromosome. Cells can be haploid or diploid. The haploid complement is constituted by a single set of homologues, one of each autosome plus one sex chromosome ($n=23$) and can only be found, in the gametocytes (sperm and ovum). The diploid complement consists of a double set ($2n=46$) and can be found in all other cells of the human body (Gardner & Amor, 2018).

The chromosomes normally are arranged in 7 groups, from A to G, resulting in a karyotype, which refers to an individual's collection of chromosomes, allowing the analysis and identification of possible anomalies in the number and/or structure of the chromosomes. Numerical and structural chromosomal anomalies are linked to a variety of congenital abnormalities, intellectual impairment, and cancer (Gersen & Keagle, 2013).

The written description of a karyotype comprises the total number of chromosomes, the sex chromosome complement, and any chromosomal abnormalities present while following the ISCN nomenclature guidelines. For example, the male karyotype seen in the figure 2 (below) would be described as 46, XY. In general, sex chromosome abnormalities are always mentioned first, followed by autosomal abnormalities. In addition, numerical anomalies are represented first, followed by structural abnormalities, among other rules (Nussbaum, McInnes, Willard, & Hamosh, 2007), (Gardner & Amor, 2018), (Gersen & Keagle, 2013).

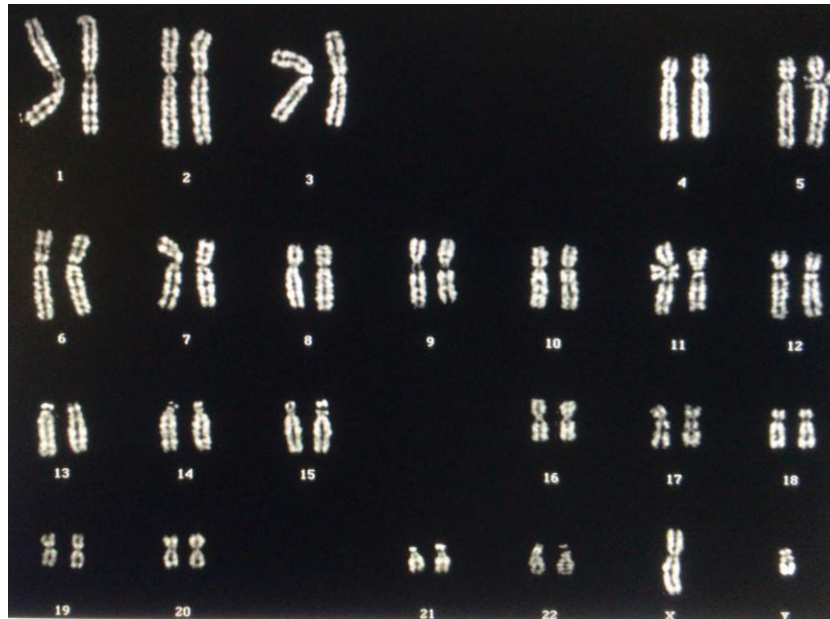

Figure 2 – Normal male karyotype.

Banding methods generate a series of bands along the metaphase chromosomes, allowing their identification (karyotyping) as well as the discovery of numerical and/or structural chromosomal abnormalities such as translocations between chromosomes, inversions, deletions, or amplifications of chromosome segments. The technique used will determine the banding resolution (Gersen & Keagle, 2013), (Ribeiro, Carreira, & Melo, 2018).

Some of the most common techniques are, G-banding, Q-banding, R-banding, and C-banding, among others. While, G-, Q-, and R-banding techniques generate a pattern of bands along the chromosomes, the C-banding technique is used to identify a specific chromosomal region, particularly, the centromere (Gersen & Keagle, 2013), (Ribeiro, Carreira, & Melo, 2018).

Conventional cytogenetic techniques have a low resolution. It can only detect chromosome structural rearrangements between 5 and 10 Mb, therefore any aberration smaller than 5 Mb cannot be detected by conventional cytogenetics (Gersen & Keagle, 2013). The resolution will be determined by a variety of factors, including the quality of the microscope and/or metaphases, as well as the degree of chromosome compaction (Li & Pinkel, 2006), (Ribeiro, Carreira, & Melo, 2018), (Gersen & Keagle, 2013).

2.2. DNA

The DNA molecule is made up of two mutually complementary DNA chains that are made up of nucleotides, which are composed of a deoxyribose sugar, a phosphate group, and one of the four nitrogen-containing bases: adenine (A), guanine (G), cytosine (C), or thymine (T). Guanine always pairs with cytosine, while adenine always pairs with thymine (Gersen & Keagle, 2013).

Replication is the process through which DNA is synthesized. It will occur on both strands of DNA, which will function as templates.

Genes are DNA sequences that contain protein-coding information (Gersen & Keagle, 2013).

Genetic information in the DNA is organized in the form of a code. The division of the DNA sequence into triplets is referred to as codons, each code for an amino acid, which will eventually be joined together to form proteins. The transcription of DNA into a corresponding mRNA (messenger RNA) molecule is the initial step in protein synthesis. RNA is a single-stranded molecule identical to DNA, except it contains ribose sugar instead of deoxyribose and uracil instead of thymine. After being processed and translated by ribosomes, this mRNA will give rise to a chain of amino acids and, as a result, proteins (Gersen & Keagle, 2013).

2.3. Chromosomal Anomalies

Chromosomal abnormalities can be constitutional (present in the individual since birth) or acquired (appear during the individual's life). They can also be classified as numerical or structural.

Numerical Chromosomal Anomalies

Numerical chromosomal abnormalities are one of the main causes of spontaneous abortions or congenital malformations. They can be divided into two groups: euploidy or aneuploidy. The etiology of these events is variable; however, most are associated with errors during cell division (Gardner & Amor, 2018), (Gersen & Keagle, 2013).

Euploidy refers to changes in the genome involving the complete set of chromosomes, mostly in the form of triploidy ($n=69$ chromosomes, since there is one extra copy of all

the chromosomes, i.e., 23 extra chromosomes) or tetraploidy ($n=92$ chromosomes). Such cases are very rare in live births (Gardner & Amor, 2018), (Gersen & Keagle, 2013).

Aneuploidies involve the loss or gain of one or more chromosomes. For example, the gain of one chromosome, called trisomies, or the loss of one chromosome, called monosomies. Currently, only trisomies involving autosomes 13 (Patau's syndrome), 18 (Edwards' syndrome) and 21 (Down syndrome) and three sex chromosome trisomies, XXY (Klinefelter's syndrome), XXX and XYY are considered compatible with life. On the other hand, monosomies are extremely rare in live births, but there's an exception, monosomy of the X chromosome, known as Turner syndrome (Gardner & Amor, 2018), (Gersen & Keagle, 2013).

Structural Chromosomal Anomalies

Structural chromosomal abnormalities can be of various types, *de novo* or inherited. These can be classified as balanced or unbalanced. Essentially, what differs them is whether there is a loss or gain of genetic material, if this occurs, it is an unbalanced abnormality. Any change that disrupts the normal balance of functional genes can result in abnormal development (Gardner & Amor, 2018), (Gersen & Keagle, 2013).

Among the balanced chromosomal anomalies, we have translocations (reciprocal or Robertsonian) and inversions (pericentric or paracentric). In the unbalanced structural chromosomal anomalies, we can have duplications, deletions, isochromosomes, marker chromosomes, ring chromosomes or insertions (Gardner & Amor, 2018), (Gersen & Keagle, 2013).

3. Introduction to Molecular Cytogenetics

3.1. Fluorescence *In Situ* Hybridization

FISH (fluorescence *in situ* hybridization) a molecular cytogenetic technique, which was developed in the late 1980s, has a variety of possible applications in research and diagnosis. This technique can be used to identify chromosomal rearrangements not visible by conventional cytogenetics, as well to assess copy number variations of oncogenes amplified in tumor cells or to diagnose number abnormalities in the chromosomal complement by using probes with high sensitivity and specificity for specific chromosomes, chromosomal regions, or genes (Fan, Y., 2010), (Liehr, T., 2013).

This technique consists of the hybridization of a DNA probe to a complementary DNA sequence on chromosomal preparations previously fixed on slides. FISH has a resolving capacity of approximately 2 to 3 Mb in metaphase chromosomes and of more than 50 kb in interphase chromosomes (Fan, 2010), (Liehr & Springer-Verlag GmbH, 2013), (Volpi & Bridger, 2008).

FISH Probes

Probes can be labelled directly by the incorporation of nucleotides bound to fluorochromes, or indirectly by the incorporation of nucleotides attached to a molecule (e.g., biotin) that then binds to fluorochrome-labelled antibodies (Liehr & Springer-Verlag GmbH, 2013), (Volpi & Bridger, 2008).

Human DNA sequences of all types have been used as probes in molecular cytogenetic research. They can be classified into two principal types based on their application: centromeric and locus-specific probes (Bayani & Squire, 2004),(UOC Laboratorio Genetica Umana), (Fan, 2010).

Centromeric or repeated sequence probes generate stronger and more visible signals These are unique to each centromere, except for chromosomes 13/21 and 14/22, whose centromeres have a high degree of similarity. These probes are very used to detect aneuploidies in the interphase nucleus, the origin of supernumerary marker chromosomes, etc., (Bayani & Squire, 2004), (UOC Laboratorio Genetica Umana), (Fan, 2010).

Locus-specific probes or single sequences are employed when, for example, a microdeletion syndrome is suspected (Bayani & Squire, 2004), (UOC Laboratorio Genetica Umana), (Fan, 2010).

Whole chromosome painting probes are also available, allowing the characterization and identification of chromosomes or supernumerary marker chromosomes of unknown origin (Bayani & Squire, 2004), (UOC Laboratorio Genetica Umana), (Fan, 2010).

In the FISH technique, more than one probe, each labelled with a distinct fluorochrome, can be used at the same time ("multiplex" FISH), since they will hybridize with a specific unique DNA or RNA sequence (Bayani & Squire, 2004), (UOC Laboratorio Genetica Umana), (Fan, 2010).

Advantages and Disadvantages of FISH

When compared to chromosome karyotype analysis, the main advantage of FISH is that it can be performed not only on metaphase chromosomes but also on interphase cells, without the requirement for cell cultures, which allows quick screenings of both numerical and structural anomalies, as well as being a very sensitive technique (Fan, 2010).

On the other way, a disadvantage of FISH is that is quite specific since the probes are unique to each genomic region. Therefore, the detection of some mutations in the genome may be missed depending on the probe design. Consequently, we are limited to the probes available, the number of loci that can be analysed simultaneously and consequently the successive hybridisations necessary to reach a diagnosis (Fan, 2010).

FISH's purposes and scope

FISH can be applied in the pre- and postnatal cytogenetics area, for the following purposes: (Bayani & Squire, 2004), (UOC Laboratorio Genetica Umana).

- Detection of aneuploidies in mosaic
- Identification of supernumerary marker chromosomes
- Search for microdeletions
- Confirmation of Array-CGH results (Array-Comparative Genomic Hybridization)
- Chromosome rearrangements

- Search for subtelomeric rearrangements
- To emphasize the breakpoints involved in chromosomal rearrangements for research purposes

4. My Internship Experience in the Institute Giannina Gaslini

4.1. Laboratory of Postnatal and Hemato-oncological cytogenetics

Most of my internship in the institute Giannina Gaslini was spent in the laboratory of postnatal, molecular, and hemato-oncological cytogenetics. There its performed postnatal and oncological cytogenetics using peripheral blood, bone marrow and tumour biopsies samples, respectively. In addition, they also perform FISH and Array-CGH.

On average, the laboratory receives approximately, per week, 20-25 peripheral blood samples and around 4-5 of bone marrow samples. As a result, they receive on average around 1300 peripheral blood samples and about 250 bone marrow samples per year. Solid tumour samples are rarer, about 1 per month.

Throughout the use of conventional and molecular cytogenetics techniques, such as karyotyping, FISH and Array-CGH, it is possible to:

- Identify and characterize small supernumerary chromosomes (markers)
- Identify and characterize structural chromosomal rearrangements (reciprocal translocation, Robertsonian translocations, insertions, inversions, duplications, deletions, isochromosomes, ring chromosomes, etc.)
- Search for autosomal or sex chromosomal aneuploidies
- Search for mosaicism

Indication for the study of the samples

The laboratory normally receives samples with the following clinical indication:

- Infertility
- MAP (medically assisted procreation)
- Men with oligospermia, azospermia, etc.
- Poly-abortionity
- Suspects of Turner syndrome
- Suspects of Klinefelter syndrome

- Suspects of Down syndrome
- Primary amenorrhea
- Small stature (mostly girls)
- Individuals with a case of intellectual disability in their family
- Change of sex
- Clitoral hypertrophy
- Urgent pregnant women
- Among others

I performed more than 400 karyotypes of clinical cases of post-natal cytogenetics, addressing almost all the previously mentioned indications of study, from Klinefelter syndrome suspects, to neonates suspects of Down syndrome. However, a considerable majority of these cases, maybe more than half, involved couples with infertility or undergoing MAP.

PRE-ANALYTICAL PHASE

Samples

The turnaround time for cytogenetic study results is, at maximum, one month to deliver the final report. The count starts when the samples first arrive at the laboratory and are registered, however, some cases have priority over others, for example, cases of urgent pregnant women and/or newborns, even if these urgent samples are received after.

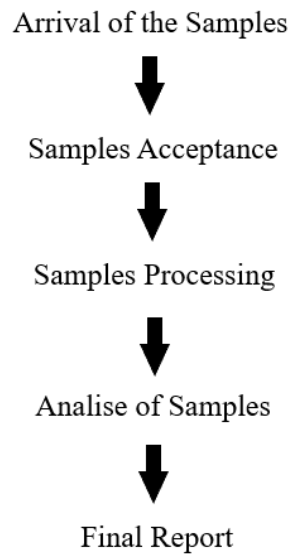

Figure 3 – Flowchart from the arrival of the samples to the laboratory until the final report.

The Arrival of the Samples

The samples that arrive at the laboratory to be analysed, might come from within the institute, from outside of it, from anywhere in Italy, and in some cases even from other countries.

Samples are delivered to the cytogenetics laboratory in building 15. If they arrive from somewhere outside the hospital, the origin and associated documentation must be checked, and the sample's information must be added to the acceptance record. The administrative employees, who receive the sample, register the data in the informatic system (ARMONIA) to perform the sample analysis. Following that, the exam requested can be viewed in the system, and a specific code is assigned, (e.g., samples of peripheral blood, will be identified by the following code: 21-CPO-0001, corresponding to the year, postnatal karyotype and the number of the patient, respectively), that is automatically associated with the patient for the exam and the report. If they come from within the hospital Giannina Gaslini, they are registered in the hospital system immediately after the collection of the sample and then transferred to the laboratory.

Samples Acceptance

The laboratory accepts samples every working day, except on Wednesdays, because the culture time is 72h and to avoid processing the sample on the weekend, the cultures

are only performed on Mondays, Tuesdays, Thursdays and Fridays. If a sample comes on a different day from the supposed one, then it's stored at room temperature and processed as soon as possible.

Before processing the samples, it's necessary to print the worksheet from the ARMONIA system, which contains the traceability of the various phases of the exam, such as the start of the culture, date of the spreading, microscopic analysis, report, as well as the date and name of the operators who performed the analysis. The worksheet also includes information regarding the patient's condition and the medical indication for the exam. To perform an individual's karyotype, informed consent must be filled by the patient, or, if he/she is a minor, by his legal representatives, during the pre-test genetic counselling session.

Area Aggregazione Servizi e Laboratori Diagnostici
U.O.C. Laboratorio di Genetica Umana
 Certificazioni ISO9001:2015 e SIGU CERT
 Direttore Dott. Domenico Coviello

Citog. postnatale

Paziente: [redacted] Data di nascita: [redacted] Codice Lab: 22-CPO-[redacted]
 Partner: [redacted] Inviato da: [redacted]
 Data arrivo campione: 16/06/2022
 Campione di: Sangue Periferico Partner: [redacted]
 Motivo invio: PMA

Sesso: M Conservazione fondello: SI NO

Notizie cliniche:

	Data	Operatore	Note
Allestimento campione	17/6/2022	[redacted]	
Striscio vetrini	22/6/22	[redacted]	
Analisi al microscopio			

Metafasi Contate
 Metafasi Cr. Appaiati
 Metafasi Cariotipate

NOTE

REFERTO

Le specifiche del kit terreno utilizzato, le date e i nomi degli operatori che si sono occupati dell'allestimento e del sacrificio delle colture cellulari sono riportati nel file digitale il cui percorso è Computer:\Common\Area\TRACCIABILITA\MAGAZZINO VIRTUALE\CPO-FISH\Tracciabilita' Postnatale

16/06/2022 Foglio di lavoro: Citog. postnatale 1/1

Figure 4 – Example of a worksheet used in postnatal and hemato-oncology cytogenetics.

4.1.1. Methodology – Peripheral Blood Samples

4.1.1.1. Culture of Peripheral Blood Lymphocytes for Chromosome Analysis

ANALYTICAL PHASE

Karyotypes provide a wide perspective of the genome. Although molecular technologies enable a more detailed analysis of specific areas of the genome, genetics is incomplete without an appreciation of a metaphase. Peripheral blood is a straightforward and reproducible source of large quantities of mitotic cells, which can be employed in clinical diagnosis or research, to study the chromosomes (Gersen & Keagle, 2013).

The culture of peripheral blood lymphocytes is also known as Standard Karyotyping. The chromosomes in metaphase obtained by this method can be used to prepare slides for conventional cytogenetic studies or to carry out additional molecular cytogenetic applications, such as the FISH (Gersen & Keagle, 2013).

Sample Collection

It is critical to obtain enough sample and that it's in good condition, before beginning the peripheral blood lymphocyte culture process for chromosomal analysis. A minimum of 1.5 ml of peripheral blood is required for karyotyping, which should be obtained aseptically and deposited in a sterile tube containing heparin. Until cultured, it must be stored at room temperature. Heparin is an anticoagulant that does not affect cell size or shape. Anticoagulants act by reducing the clotting ability of the blood (Gersen & Keagle, 2013).

The aim of karyotyping is to capture cells at metaphase, since it corresponds to the phase in which the chromosomes are at their most condensed state, therefore they are easier to distinguish. After the samples are registered, they can be cultured.

Preparation of standard lymphocyte cultures

Peripheral blood samples should be cultured within 24 hours of collection. *Chromosome medium P** (Euroclone) is the complete medium (which contains antibiotic, fetal bovine serum (FBS) and L-glutamine) used in the laboratory in cell culture for standard karyotyping. T-lymphocytes in the peripheral circulation do not undergo cell division spontaneously, thus, they must be stimulated by the addition of the mitogen phytohemagglutinin present in the culture medium.

The worksheet includes the medium characteristics, the date, and the name of the operator who established the cell culture. The culture is carried out in an aqueous growth medium in sterile centrifuge tubes.

Each sterile tube will include 5 ml of culture medium and the direct addition of 0.6 ml of blood, for children over the age of 3 months and adults (standard method). The remaining blood is kept in the fridge at 4°C until the case is finished and reported.

Before starting the cell cultures, the labels for the tubes are prepared, containing the patient's first and last name, the laboratory's internal code, and the date of cell culture initiation to avoid mistakes, for example, in the exchange of samples. After the cultures have been initiated, they are placed in the incubator at 37°C, with temperature, humidity and pH controlled, for 72 hours (this period can vary according to the type of sample used) (Gersen & Keagle, 2013).

After the first 48 hours, 100 µl of Syncroset A is added, and the tubes return to the incubator overnight. In the following morning, 100 µl of Syncroset B is added, and the cultures return to the incubator for another 5 hours.

In the laboratory, they use a synchronisation kit for peripheral blood, more specifically, the Syncroset kit (Euroclone). Syncroset A solution contains methotrexate (MTX), a thymidine biosynthesis inhibitor that will synchronize cells in the same cell cycle phase by lowering the quantities of accessible thymidine, which is necessary for DNA synthesis (S phase). Syncroset B solution contains a high level of thymidine, therefore, when added to the culture, causes the release of the MTX block, allowing the cells to proceed synchronously to mitosis (Gersen & Keagle, 2013).

Harvesting chromosomes in mitosis

When we have a sufficient number of cells, they are blocked in metaphase at the end of the incubation period by adding 30 μ l of colcemid (mitotic inhibitor) to the cultures and placing them back in the incubator for another 60 minutes. The colcemid depolymerizes the mitotic spindle, and so arrests the cells at this stage by binding to the tubulin protein and interfering with the synthesis of the microtubules. This treatment causes mitotic arrest and, as a result, an accumulation of cells in metaphase (Gersen & Keagle, 2013).

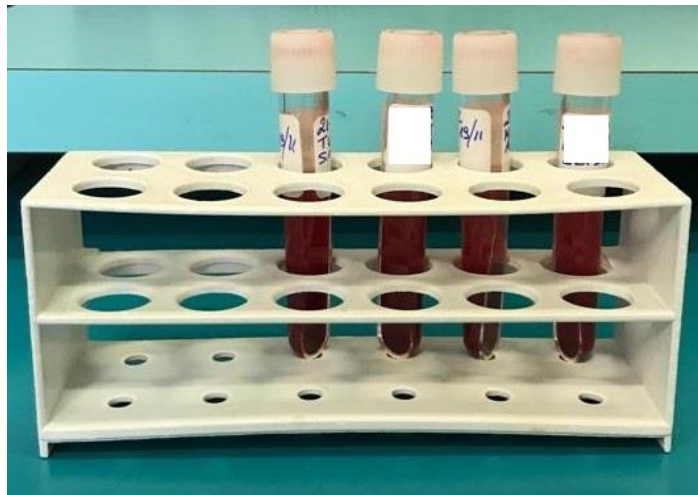

Figure 5 – Peripheral blood samples after chromosome harvesting and before the hypotonic shock.

Hypotonic solution

After exposure to colcemid, the cultures are centrifuged for 5 minutes at 1500 rpm. The supernatant is then removed, and the pellet is resuspended in 4 ml of hypotonic solution (pre-warmed in a water bath at 37°C) and kept at room temperature for 8 minutes. Hypotonic therapy with potassium chloride (KCl) promotes cell swelling, since the hypotonic solution has a lower salt concentration than the cell cytoplasm, allowing water to enter the cell by osmosis and consequently, helping the spreading of the chromosomes on the microscope slide. However, the exposure time of the cells to the hypotonic solution is very important since, too much time may cause the cells to burst and too little time may not be enough for the cells to swell, resulting in poor chromosome spreading (Gersen & Keagle, 2013).

Fixation of the chromosomes

After 8 minutes of the hypotonic solution, 4 ml of fixative solution (freshly made) is added, which contains methanol and acetic acid in a 3:1 ratio, respectively. The fixative stops the action of the hypotonic solution and fixes cells in the swollen state. In addition, it will also lyse the red blood cells (RBCs) present in the samples. The samples are centrifuged at 1200 rpm for 10 minutes. The supernatant is then removed, and the pellet is resuspended in 5 ml of fixative solution. The samples are washed three times with the fixative and centrifuged for 5 minutes at 1500 rpm between washes. If the samples are not spread out immediately, they are stored in fixative solution at -20°C (Gersen & Keagle, 2013).

When the cells are fixed, the water is removed, which destroys the cell membranes before they are dispersed on the slides. The fixative should be produced fresh before use because it absorbs water from the surrounding environment, affecting the quality and banding of the chromosomes.

The first fixation is an important phase in the protocol. Some people like to administer the fixative to the cells slowly and continuously in the vortex, while others prefer to add it directly to the samples with a pipette.

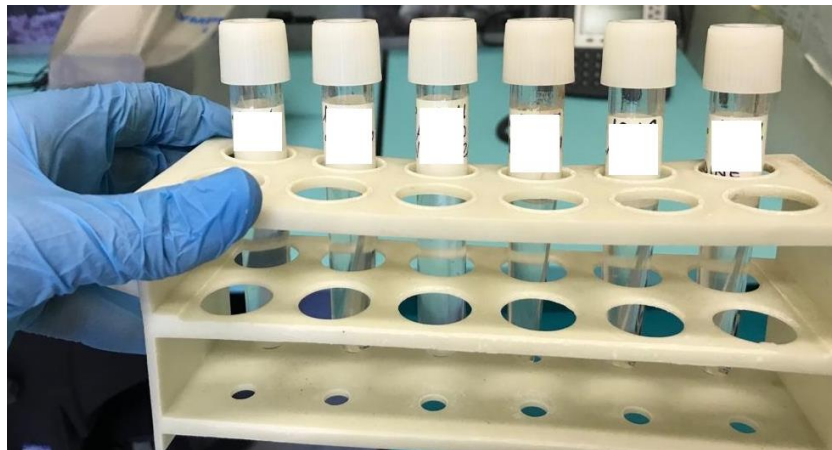

Figure 6 – Samples after chromosome fixation, ready to be spread.

Chromosome spreading

The last step of the harvesting procedure is the spreading of the chromosomes, however, before starting this step, the glass slides should be identified with the patient's

first and last name, the laboratory code corresponding to the individual in question, and the date of the spreading.

The resultant pellet of the chromosome's fixation is resuspended in 1.5 ml of fixative (freshly prepared), it should be proportional to the amount of pellet. Two slides are prepared for each patient/sample.

Many factors affect the quality of the spreading, from temperature to the angle and height at which the cells are dropped, etc., so it is important to take all these variables into account and decide, based on experience, which spreading method is best for each operator, since there is no specific way to do it, so it can be done in different forms.

After the spreading, the glass slides are then placed in the climatization chamber, where temperature (28°C) and humidity (36%) are controlled. Given that, when the cells reach the slide the fixative starts to evaporate, this causes that as it evaporates the cell membranes start to stretch. Consequently, the longer the evaporation takes, the more spread out the cells and chromosomes become, which is something we don't want in excess. Therefore, it is important to have the temperature and humidity controlled to have the best possible spread (Gersen & Keagle, 2013).

After the slides are dry, the quality is assessed by using a phase-contrast microscope, to check cell density, mitotic index, and metaphases quality, since we want enough metaphases, well spread out, without overlapping chromosomes and no visible cytoplasm (Gersen & Keagle, 2013).

Chromosome staining

In the laboratory they use the Q-banding technique which is one of the most used banding methods. In this technique you treat the chromosomes with quinacrine mustard, which will intercalate the base pairs of the DNA helix, producing a yellow fluorescence Q-banding pattern of bright and dark bands on the chromosomes when excited by UV light. The bright fluorescent bands are A-T rich, while the dark bands are C-G rich (Schreck & Distèche, 2001).

Q-banding is very beneficial for spotting rare variations in chromosome morphology or staining, known as heteromorphisms. The technique's downside is that the fluorescent intensity decreases quickly, therefore observation and acquisition must be taken within a few minutes of staining.

Staining of chromosomes should be done immediately before the microscopic analysis. We have four recipients, one with quinacrine mustard, two with distilled water, and one with Mc-Ilvaine solution. The banding procedure starts with the immersion of the glass slides in the quinacrine for around 10-15 minutes, followed by 2 short washes in distilled water and, finally, one last wash in the Mc-Ilvaine solution (filtered). Then we put the coverslip on the glass slide, remove the excess water with paper and finish sealing it with varnish.



Figure 7 – Preparation of all the materials and solutions necessary for the chromosome staining with the quinacrine mustard.

Slide reading: image acquisition, metaphase analysis, karyotype construction and interpretation of results

For the analysis and interpretation of the results, a standard karyotype is created. Each chromosome is placed in the karyotype according to its centromere position, size, and banding pattern.

When the slides are completely dry, they're ready to be examined, more specifically the chromosome's morphology, chromosomal complement total number, banding resolution, and sex chromosomes complement.

A fluorescent microscope is used to examine the slides. The microscope is linked to a computer, which is used to process the acquired metaphases, with the help of informatic software.

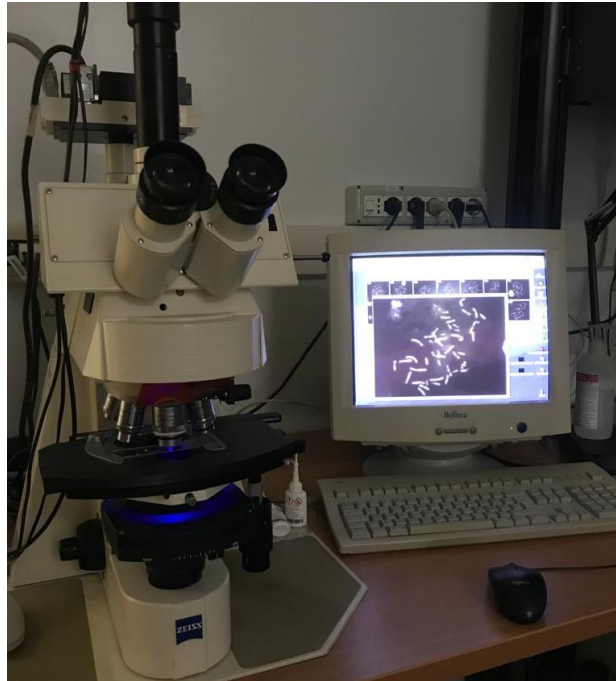

Figure 8 – Microscope and computer used in the postnatal cytogenetics laboratory.

The photos are recorded in files that include:

- Subject's name, surname, date of birth, and laboratory internal code
- Sample's arrival date
- Type of material being examined

Generally, in the laboratory, the technicians perform the practical part of the protocols, for example, in the protocol for the culture of peripheral blood lymphocytes for chromosomal analysis, while the biologists, although they can also do this, usually they do the microscopic analysis of the slides, and consequently of the karyotypes and the final report of the results obtained, always in accordance with the criteria defined by the SIGU, as well as the guidelines of the ACMG (American College of Medical Genetics).

While we examine the slides under the microscope, normally, per slide, we acquire an image of the best 16 metaphases, so we analyse and count at least 16 metaphases for each sample and construct 4 karyotypes using homologous chromosomal pairing, in which at least two karyotypes should have a minimum resolution of 400 bands, and the other two should not have a resolution far below this. In each karyotype constructed, it is important to analyse each chromosome individually, band-by-band, to compare it with the homologous chromosome and between the different karyotypes.

Any anomalies discovered should always be documented. If mosaic aneuploidy (excluding monosomy of an autosome) is found in the first 16 metaphases, the count and acquisition are increased to 30. If a second metaphase with the same anomaly is discovered, the count is increased to 50. However, in most of the cases, if we find only one metaphase with a numerical or structural anomaly, we dismiss it, since there can be numerous explanations, for example, the metaphases can be spread out, and some chromosomes can be lost due to poor spreading.

According to the clinical indications, there are cases, in which 30 metaphases must be analysed and acquired with the construction of 4 karyotypes. For example:

- Primary or secondary amenorrhoea
- Klinefelter syndrome
- Turner syndrome
- Ambiguous genitalia
- Supernumerary chromosome marker in an individual with a family background of carriers of the same marker in the karyotype, and suspected mosaic aneuploidy
- Confirmation of chromosomal aneuploidy discovered prenatally
- Among others

Each sample is analysed in accordance with the SIGU and E.C.A. recommendations (European Cytogenetics Association).

POST-ANALYTICAL PHASE

Report

In the laboratory, the senior biologist is in charge of writing the reports, using the informatic system ARMONIA. The report usually includes the description of the patient's personal information (name, surname, birth date and sex), the name of the doctor that prescribed the exam, the culture and banding technique used, the number of metaphases analysed, constructed karyotypes, their resolution, and the final karyotype. As well as the clinical interpretation of the results, including the recommendation of additional tests and/or genetic counselling.

Reports must be written within 28 working days of sample delivery; in urgent situations, such as a pregnant women with a fetus with a suspected chromosomal abnormality, confirmation/exclusion of suspected aneuploidy in newborns, among others, reports must be written within 7 working days. The biologist is also responsible for archiving old cases.



The image shows a formal report from the U.O.C. Laboratorio di Genetica Umana at IRCCS G. Gaslini. It includes a header with the hospital logo and name, followed by the report title 'Indagine citogenetica' and the date 'Genova 21/10/2021'. The report contains patient information, laboratory details, technical specifications, and a detailed conclusion regarding a chromosomal mosaicism. The conclusion states: 'Conclusioni: Cariotipo a mosaico con presenza di due linee cellulari, una a 46 cromosomi con un cromosoma X ed un cromosoma Y isodentrico per le braccia corte risultante nella perdita della regione Yq11qter e duplicazione della regione Ypterq11 in diciannove metafasi sulle trenta analizzate, una a 45 cromosomi con monosomia X in undici metafasi sulle trenta analizzate.' The report is signed by the Sector Director and the Laboratory Director.

Area Aggregazione Servizi e Laboratori Diagnostici
U.O.C. Laboratorio di Genetica Umana
Certificazioni ISO9001:2015 e SIGU CERT
Direttore Dott. Domenico Coviello

Indagine citogenetica Genova 21/10/2021

Cognome e Nome:
Codice Lab:
Luogo e data di nascita: Sesso:M

Inviato da: .
Ospedale: IRCCS G. GASLINI - Genova
Indicazione all'indagine: Azoospermia
Data accettazione campione: 11/10/2021
Materiale esaminato: Sangue Periferico

Tecnica utilizzata: Colture di linfociti con PHA ○

Colorazioni eseguite: QFQ

Risoluzione in bande N°: 400

Culture analizzate N°: 1

Cellule in metafase esaminate N°: 30

CARIOTIPO COSTITUZIONALE: mos 46,X,idelic(Y)(q11)[19]/45,X[11]

Conclusioni: Cariotipo a mosaico con presenza di due linee cellulari, una a 46 cromosomi con un cromosoma X ed un cromosoma Y isodentrico per le braccia corte risultante nella perdita della regione Yq11qter e duplicazione della regione Ypterq11 in diciannove metafasi sulle trenta analizzate, una a 45 cromosomi con monosomia X in undici metafasi sulle trenta analizzate.

Note: Si consiglia consulenza genetica

Dirigente del Settore Direttore

Figure 9 – Example of a post-natal cytogenetics final report.

After-reporting sample storage

Slides are kept for one year, beginning on the day the sample was received. After the report is completed, the pellets of the cytogenetic preparations and remaining peripheral blood samples are discarded.

Documents archive

After a case is reported, paper and electronic worksheets, as well as photographs of the metaphases obtained from the cases and karyotype analysis slides, are archived. They can be consulted later if necessary.

4.1.2. Clinical Cases

I described five clinical cases analysed during the internship, to understand the laboratory strategy used for each case and the interpretation of the results.

Case 1

Name: João Ferreira *

Date of birth: 21/05/1983

Sex: Male

Clinical Indication: Infertility – Azoospermia

Man, in his forties, with azoospermia, was sent for the study of the karyotype because of infertility.

Azoospermia, or the complete lack of spermatozoa in the sperm, is one of the most common reasons for male infertility (Yu, Wei, Jiang, & Zhang, 2015).

Methodology

- Conventional cytogenetic analysis of synchronized lymphocyte cells cultured from peripheral blood samples, metaphase spreading and QFQ banding.
- FISH with an SRY mix probe, and a probe for the centromere of chromosome Y. The SRY mix probe, consists in 3 probes, one for the *SRY* gene and two control probes for the centromere of chromosome X and for the heterochromatic region at Yq12 of chromosome Y.
- PCR-based screening for the Y chromosome most common microdeletions was carried out using the kit from Devyser and performed in DNA extracted from peripheral blood leucocytes. The AZFa, AZFb and AZFc regions of the *AZF* gene were analysed.

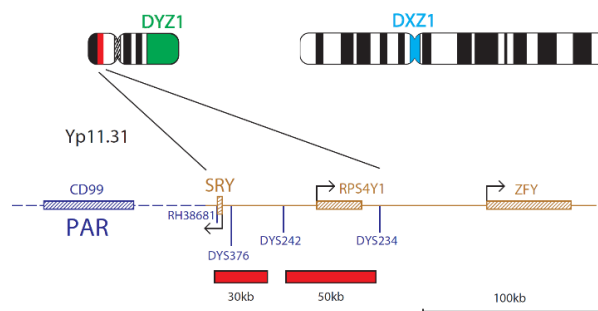

Figure 11 – Representation of the *SRY* CytoCell probe mix, where you can see the red probe covering the Yp11.31 region, the green probe for the heterochromatic region (Yq12) of the Y chromosome and the blue probe for the centromere of the X chromosome (image taken from the website: <https://www.ogt.com/products/product-search/cyto-cell-sry/>).

Analysis and Interpretation of Results

The microscopic analysis allowed the discovery of an abnormal Y chromosome present in 19 metaphases from the total of 30 metaphases, while in the remaining 11 metaphases the chromosome Y was missing.

Therefore, after a brief discussion between the laboratory staff, it was agreed that it was certainly something abnormal, with a probable deletion, maybe incorporating the *AZF* gene locus, given the clinical indication (azoospermia) and the cytogenetic discovery.

According to the guidelines, abnormal results should be confirmed by other technology, in this case, it was confirmed firstly by FISH and PCR-based screening for the Y chromosome microdeletions.

FISH analysis showed an isodicentric Y chromosome with two signals for the centromere, two signals for the *SRY* gene and no signal for the heterochromatic region (Yq12), while molecular analysis performed by PCR excluded the presence of complete/partial deletion of the *AZF* regions of the Y chromosome.

The *SRY* gene is critical for the development of secondary sexual characteristics in males, so the phenotype will depend on the percentage of *SRY* cells present in the gonads (Yang & Hao, 2019), (Lee, et al., 2015). Mutations in the *AZF* locus are thought to be pathogenic and are probably involved in the etiology of male infertility associated with azoospermia or oligozoospermia (Ozdemir, et al., 2007).

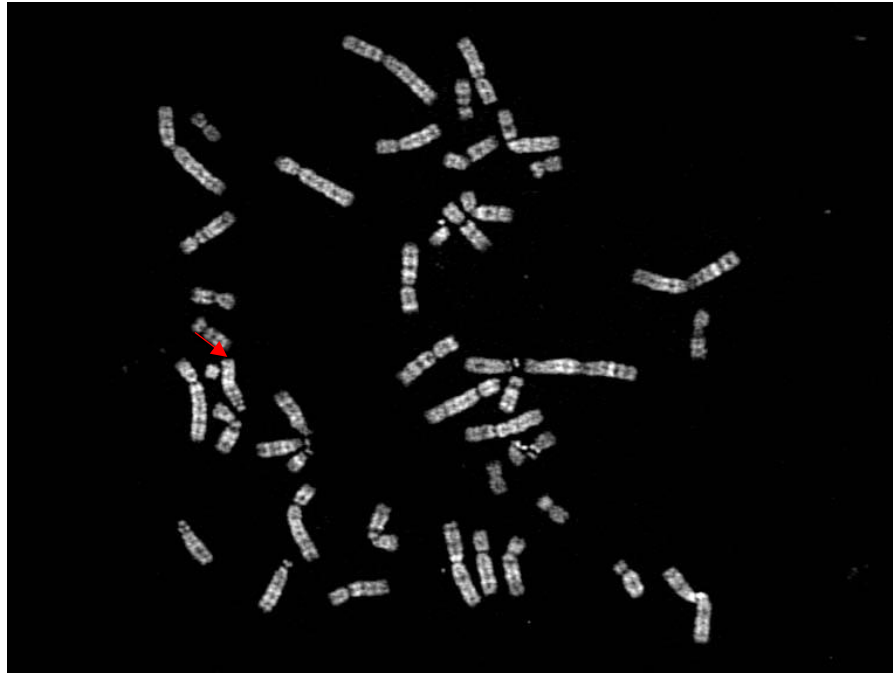

Figure 12 – João’s karyotype metaphase (image provided by the laboratory of human genetics of institute Giannina Gaslini).

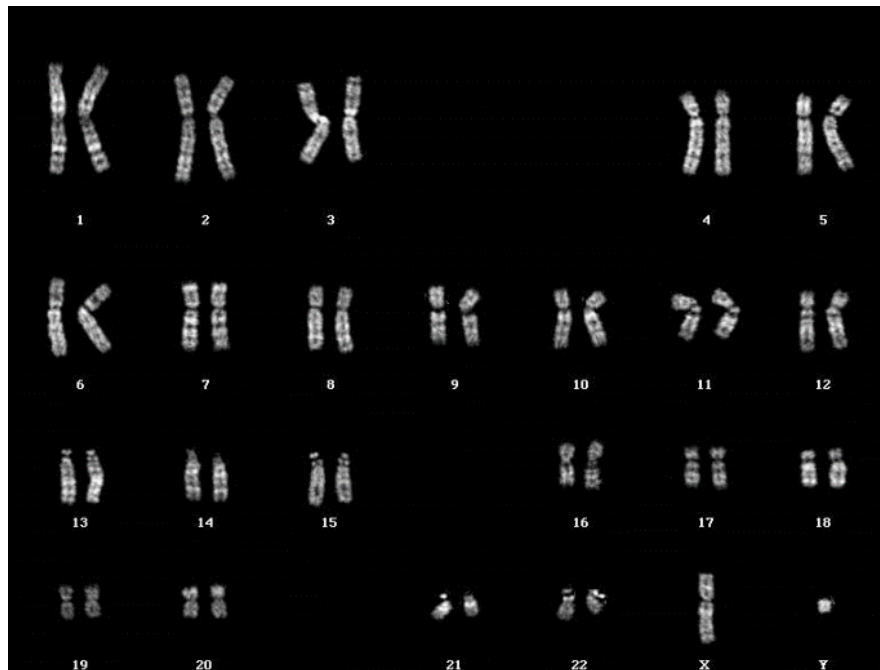

Figure 13 – João’s karyotype (image provided by the laboratory of human genetics of institute Giannina Gaslini).

Conclusion

It was concluded that this man was a mosaic with the presence of two cell lines, one 46,XY with an **isodicentric chromosome Y for the short arms** (duplication of the Ypterq11 region) resulting in the loss of the Yq11qter region present in 19/30 metaphases analysed, and the other cell line with 45,X, present in the remaining 11/30 metaphases analysed.

Chromosome abnormalities and Y-chromosomal microdeletions are the most prevalent genetic causes of male infertility; around 10 to 15% of azoospermic men have Y-chromosomal microdeletions (Yu, Wei, Jiang, & Zhang, 2015).

An isochromosome refers to an unbalanced structural chromosomal abnormality in which there is a deletion of a part of the chromosome (in this case the Yq11qter region) and a mirror duplication of the remaining chromosome.

Isodicentric chromosomes, due to the presence of two centromeres are very unstable, therefore, most of the cases result in mosaicism, being the most common type of mosaicism, the presence of a 45,X cell line, as it happened in this case. These mosaic individuals can have several phenotypic manifestations, like male infertility, ambiguous genitalia, etc. It will depend on the genes involved in the breakage and fusion of the isodicentric Y chromosome and the proportions of the mosaicism (Yang, Y., 2019), (Lee, J., 2015).

Although FISH identified the presence of an isodicentric chromosome Y, with the Yq11qter region deleted (including the AZF region), molecular analysis by PCR identified the presence of the AZF region. The discordance of these findings suggests the presence of a third cell lineage 46,XY with a normal Y chromosome, that wasn't detected by cytogenetics. Possible explanations can include the low degree of mosaicism.

In conclusion, this man's infertility is probably caused by the presence of the 45,X cell line and the presence of the isodicentric chromosome Y, which results in the deletion of the region Yq11qter, encompassing the AZF region. Genetic counselling was advised.

Final karyotype: mos 46, X, idic(Y)(q11)[19]/45,X[11]

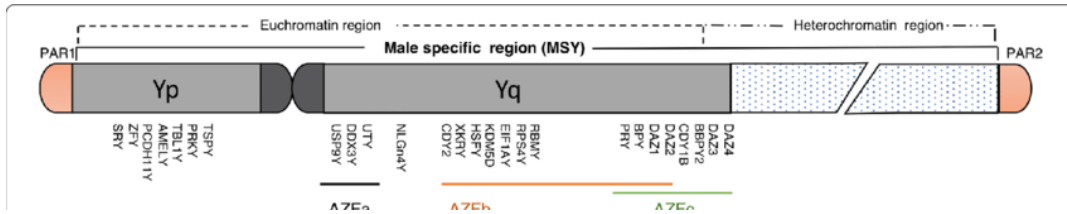

Figure 14 – Schematic representation of human Y chromosome (Y chromosome is moving out of sex determination shadow – Scientific Figure on ResearchGate. Available from: https://www.researchgate.net/figure/Schematic-representation-of-human-Y-chromosome-The-location-of-the-azoospermia-factor_fig1_357596787 [accessed 23 Jul 2022]).

* The names used in the clinical cases are fictitious.

Case 2

Name: Maria Silva

Date of birth: 08/12/2021

Sex: Female

Clinical Indication: Presence of a supernumerary marker chromosome in mosaic discovered in the prenatal period.

1-year-old girl, with a supernumerary marker chromosome in mosaic, discovered during the prenatal diagnosis (image 15). As a result, postnatal cytogenetic testing was carried out to confirm the presence of the marker.

Methodology

- Conventional cytogenetic analysis of synchronized lymphocyte cells cultured from peripheral blood samples, metaphase spreading and QFQ banding.
- Array-CGH
- FISH with a whole chromosome painting probe for chromosome 19.

Analysis and Interpretation of Results

Considering the indication of the test, and the presence of a supernumerary chromosome, after the analysis of some metaphases, we couldn't find anything abnormal, so we asked to see the images of the prenatal karyotype of this girl, to have an idea of what to look for specifically. After having access to these images, we were able to identify the supernumerary chromosome.



Figure 15 – Maria’s karyotype metaphase (image provided by the laboratory of human genetics of institute Giannina Gaslini).

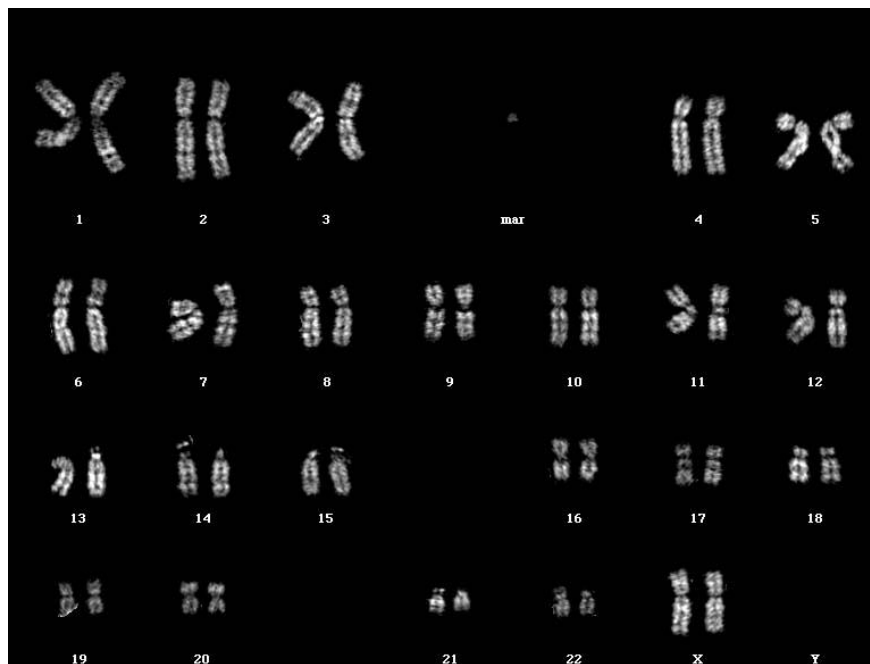

Figure 16 – Maria’s karyotype (image provided by the laboratory of human genetics of institute Giannina Gaslini).

Although the girl was phenotypically normal (so far), whenever a supernumerary marker chromosome (SMC) is identified in the prenatal period, its existence should be

always confirmed in the postnatal period. It is complicated to predict the outcome of the presence of an SMC without knowing its chromosomal origin and genetic content.

SMC are characterised as structurally abnormal chromosomes that cannot be identified or characterised by conventional cytogenetics alone, and additional use of molecular cytogenetic techniques, such as FISH, is required (Liehr, et al., 2009).

Approximately 30% of SMC cases are inherited from parents, while the remaining cases are *de novo* (Liehr, et al., 2009), (Liehr, Cirkovic, Lalic, & et al, 2013). In this case, the parents were not studied.

In addition to the karyotype, an Array-CGH was performed in the prenatal period, which showed that the girl had a duplication on chromosome 19. Consequently, in the postnatal period, besides the conventional postnatal cytogenetic analysis, FISH was also performed to confirm the result of the prenatal Array-CGH. Thus, using a whole chromosome painting probe for chromosome 19, the result of the Array-CGH was confirmed.

Conclusion

Finally, after karyotype and FISH analysis, it was confirmed that this girl, was a mosaic, with a normal cell lineage, 46,XX visualised in 22/30 metaphases, and an abnormal cell lineage, 47,XX plus a supernumerary marker derived from the chromosome 19, more precisely from the centromeric region in 8/30.

Since the girl is still quite young, clinical surveillance is suggested to verify the eventual consequences on the phenotype caused by the presence of the supernumerary marker.

Final karyotype: mos 47,XX,+der(19)del(19)(p11)del(19)(q12)[8]/46,XX[22]

Case 3

Name: Paula Cavaco

Date of birth: 11/03/1984

Sex: Female

Clinical Indication: MAP

Woman, 38 years old, with indication for MAP.

Methodology

- Conventional cytogenetic analysis of synchronized lymphocyte cells cultured from peripheral blood samples, metaphase spreading and QFQ banding.

Analysis and Interpretation of Results

During the cytogenetic analysis, it was found a reciprocal translocation, presumably balanced, between chromosomes 11 and 22, in all the 16 metaphases examined.



Figure 17 – Paula's karyotype metaphase (image provided by the laboratory of human genetics of institute Giannina Gaslini).

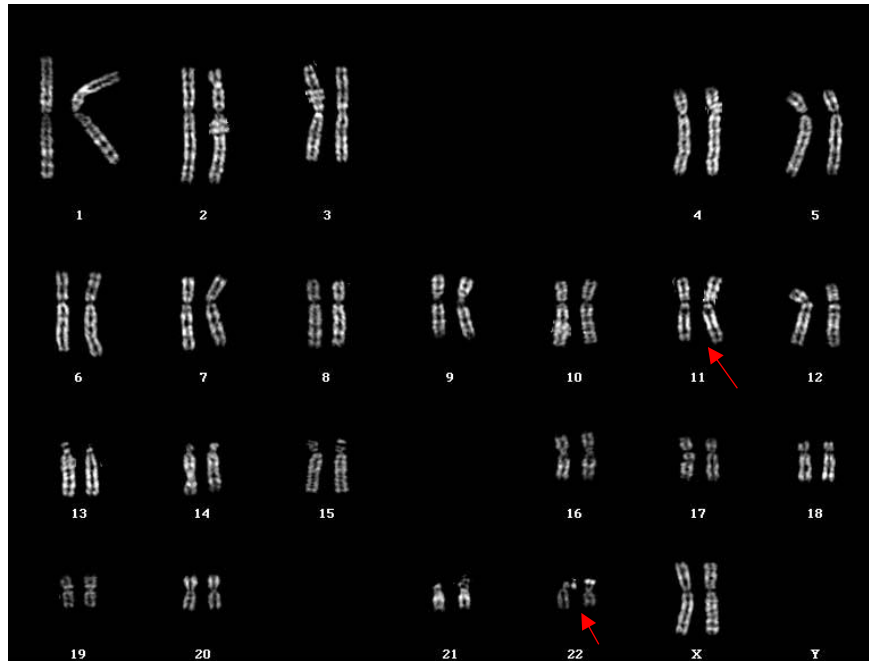

Figure 18 – Paula’s karyotype (image provided by the laboratory of human genetics of institute Giannina Gaslini).

Conclusion

According to the scientific literature that I consulted, the balanced reciprocal translocation, $t(11;22)$, is a recurrent chromosomal anomaly, reported in several families. Carriers of balanced structural chromosome rearrangements, despite not having an associated pathological phenotype, have an increased risk of generating unbalanced gametes, thus having a high risk of having offspring with congenital malformations and/or intellectual deficit, with loss or gain of genetic material, often resulting in spontaneous abortions at an early stage of pregnancy (Correll-Tash, et al., 2018).

There is a syndrome associated with this translocation, Emanuel syndrome, which results from the duplication of the regions 22q10-22q11 and 11q23-qter present on a supernumerary derivative chromosome 22 [der(22)], which originates in the $t(11;22)(q23;q11.2)$. In most cases, one parent of an individual affected by this syndrome is a healthy carrier of the balanced translocation (Emanuel BS, Zackai EH, & Medne L., 2017).

Therefore, this lady, being a carrier of this balanced translocation, should be followed by a medical geneticist, through a genetic counselling session, to be warned of all the

possible outcomes of future pregnancies, which may include: (Emanuel BS, Zackai EH, & Medne L., 2017)

- Fetus with normal chromosomal complement
- Fetus with a supernumerary der(22) syndrome
- Fetus carrier of balanced t(11;22)
- Spontaneous abortion as a result of supernumerary der(22)

All the reproductive options available should be recommended to the lady and couple's carriers of structural chromosomal abnormalities. For example, indication for prenatal diagnosis and, if the fetus presents anomalies, medical termination of pregnancy can be offered; offer of pre-implantation genetic diagnosis, allowing a selection of normal embryos before implantation in the uterus via assisted fertilization; or, at last, the possibility of adoption. Furthermore, cytogenetic testing is also offered to direct family members, such as siblings, who are at risk of also carrying chromosomal abnormalities (Correll-Tash, et al., 2018).

Finally, FISH was not performed because, through cytogenetics, it was possible to understand the breakpoints of the translocation and, also, because it has no pathogenic influence on the phenotype of this lady, since it's a reciprocal translocation without loss of genetic material.

Final karyotype: 46,XX,t(11;22)

Case 4

Name: Pedro Pinto

Date of birth: 15/03/1971

Sex: Male

Clinical Indication: Poli-abortivity on the partner

Man, 51 years old, indicated for the karyotype study because his partner had suffered multiple abortions in the past.

Methodology

- Conventional cytogenetic analysis of synchronized lymphocyte cells cultured from peripheral blood samples, metaphase spreading and QFQ banding.
- FISH with an alphoid probe for chromosomes 14 and 22.

Analysis and Interpretation of Results

After the acquisition of 16 metaphases and the construction of 4 karyotypes, we verified the presence of a marker chromosome in all the 16 metaphases analysed. After this discovery and discussion between the laboratory staff, we decided to perform FISH for chromosomes 14 and 22, since most SMC are derived from the short arms and/or pericentric regions of acrocentric chromosomes (also on the basis of a flowchart showing the steps to be followed in the presence of an SMC, as seen in figure 19).

The FISH performed demonstrated that the SMC belonged to one of the chromosomes 14 or 22, however, it is complicated to distinguish precisely from which chromosome, if the SMC don't contain euchromatin (Sun, et al., 2020), (Liehr, et al., 2021).



Figure 19 – Flowchart for the analysis of SMC cases.

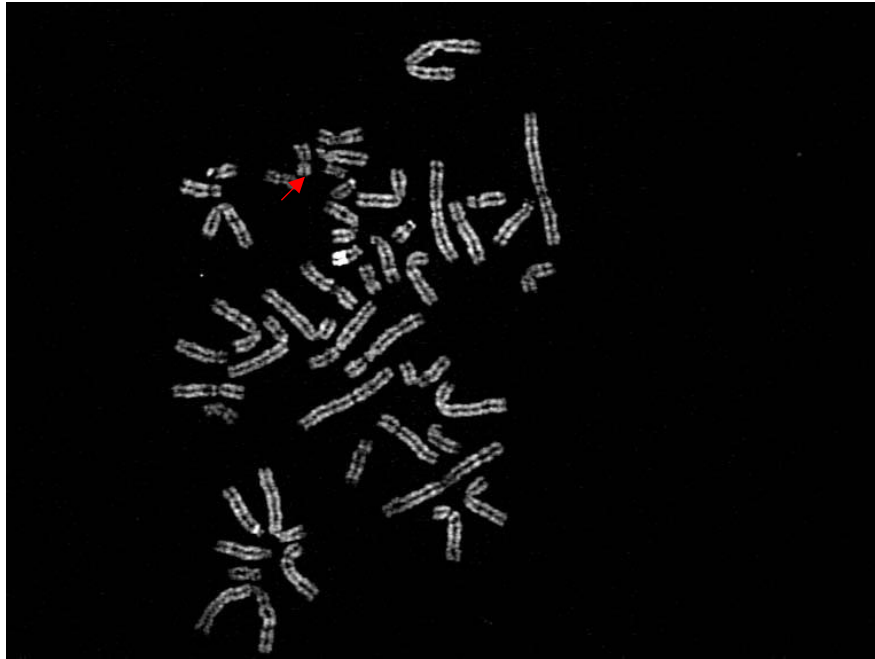

Figure 20 – Pedro's karyotype metaphase (image provided by the laboratory of human genetics of institute Giannina Gaslini).



Figure 21 – Pedro's karyotype (image provided by the laboratory of human genetics of institute Giannina Gaslini).

Conclusion

Approximately 7% of *de novo* SMCs derived from chromosomes 13/21 and 14/22 resulted in abnormal phenotype. Dysmorphic features and mental retardation are the most common characteristics for individuals with a marker derived from chromosome 14. Whereas, for individuals with a marker derived from chromosome 22, with duplications of the euchromatic region 22q11.2, present in about 80% of carriers of this anomaly, pathological phenotypes can include, cat-eye syndrome, Emanuel syndrome, or malignant tumors (Sun, et al., 2020).

In this case, since the man was phenotypically normal and with karyotype 47,XY,+mar from chromosome 14 or 22, we can conclude that this anomaly is benign, and it's not the cause behind the poli-abortion in his partner.

Final karyotype: 47,XY,+mar

Case 5

Name: Tiago Martins

Date of birth: 20/06/2017

Sex: Male

Clinical Indication: Confirmation of karyotype 47,XYY established in the prenatal diagnosis.

Boy, 5 years old, with the indication to confirm the karyotype 47,XYY established in the prenatal diagnosis.

Methodology

- Conventional cytogenetic analysis of synchronized lymphocyte cells cultured from peripheral blood samples, metaphase spreading and QFQ banding.
- FISH was performed with alphoid probes for chromosomes X and Y.

Analysis and Interpretation of Results

The cytogenetic analysis showed the presence of the extra Y chromosome in all the 30 metaphases analysed, with the construction of 4 karyotypes.

FISH was performed for this case, to confirm the boy's karyotype, 47, XYY. Thus, 100 nuclei in interphase were analysed, also to exclude the possibility of mosaicism.

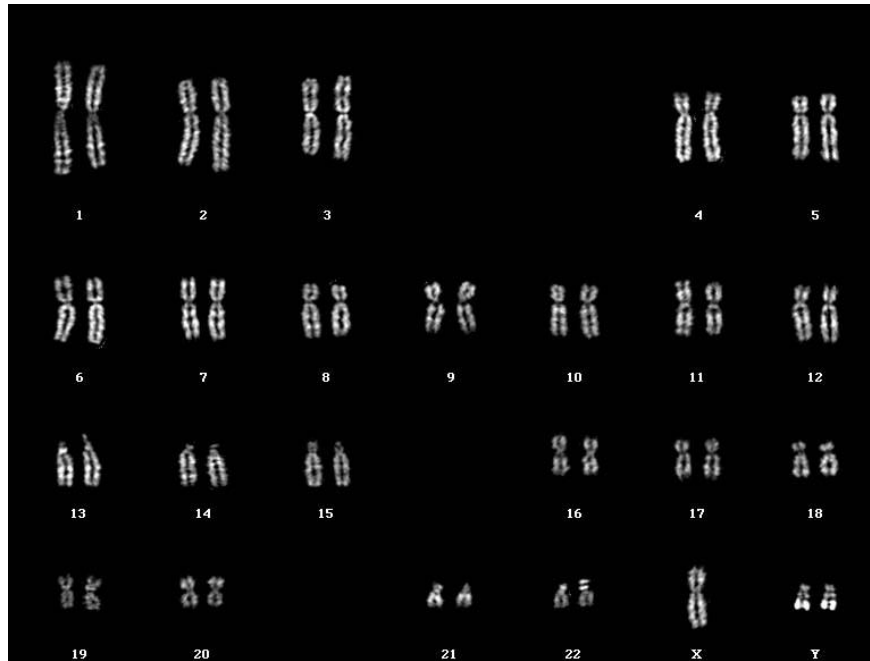

Figure 22 – Tiago’s karyotype (image provided by the laboratory of human genetics of institute Giannina Gaslini).

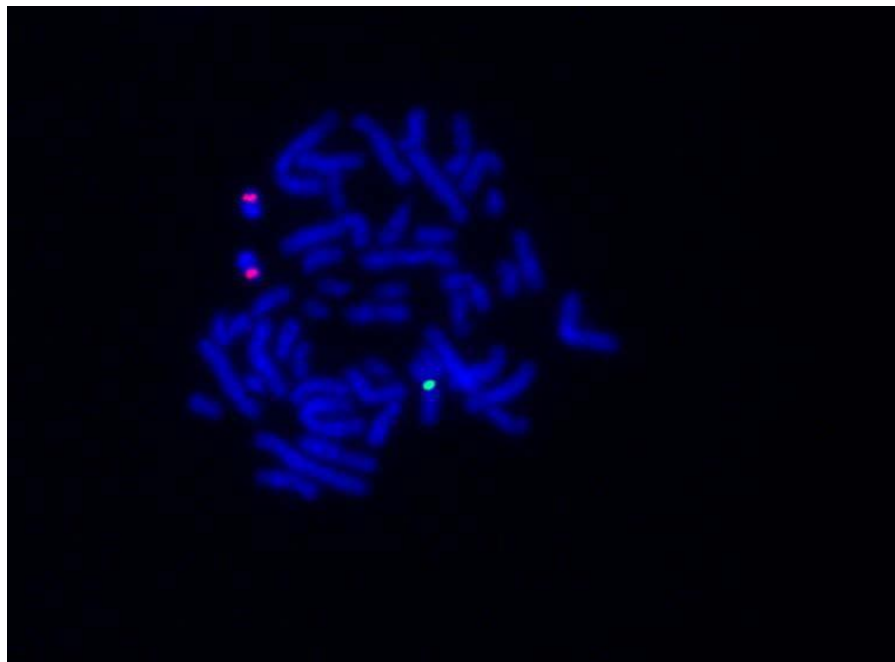

Figure 23 – Tiago’s FISH metaphase (image provided by the laboratory of human genetics of institute Giannina Gaslini).

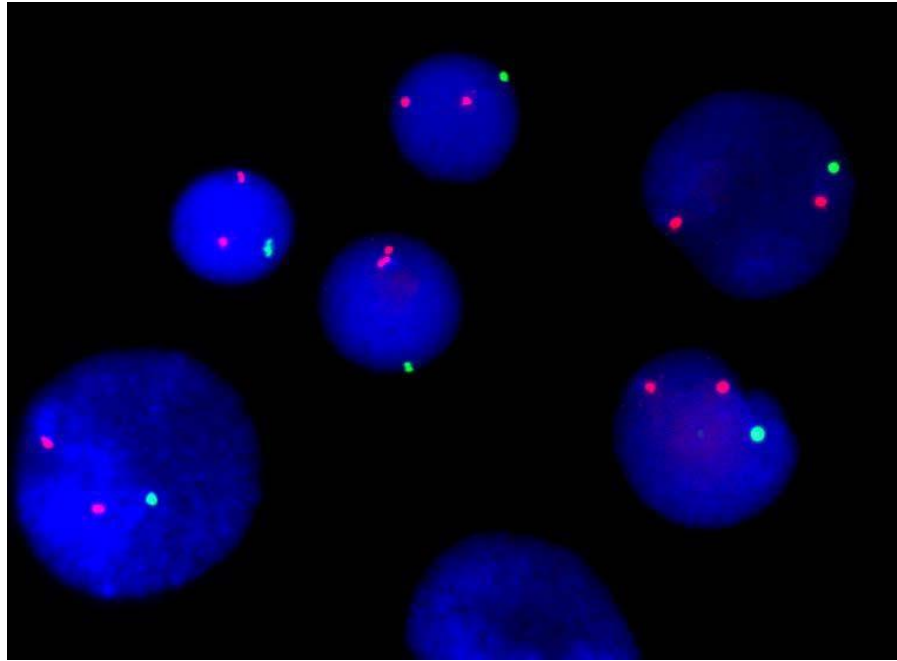

Figure 24 – Tiago’s FISH performed in nuclei in interphase (image provided by the laboratory of human genetics of institute Giannina Gaslini).

Conclusion

XYY syndrome is a chromosomal disorder that affects only males. Its characterized by the presence of an extra chromosome Y (47,XYY). The affected individuals have a very mild phenotype, thus, the majority of males with this syndrome are never diagnosed. The most common physical difference can be, increased height, macroorchidism, hypertelorism, etc. They can also present some learning disabilities and/or behaviour problems (Bardsley, et al., 2013).

Therefore, the karyotype previously established during the prenatal period was confirmed in the post-natal, as 47,XYY. Because this syndrome has no serious effects on the life of this individual, the study ended here.

Final karyotype: 47,XYY

4.1.3. Methodology – Bone Marrow Samples

Cancer is characterized by the accumulation of acquired somatic mutations, often on a genetic predisposition, causing uncontrolled proliferation of these aberrant cells that can infiltrate and affect the structure and function of normal tissues and organs. As a result, malignant cells can arise from any region of the organism (Swansbury, 2003), (Sozzi, Testi, & Croce, 1999).

Certain genetic anomalies, such as translocations, deletions, or inversions, are very common and linked to specific types of hemato-oncological malignancies. By knowing the genetic anomaly in question, a more correct prognosis can be predicted.

Cytogenetic analysis of hemato-oncological cancer samples is used to establish the presence of a malignant clone with a genetic anomaly, which aids to clarify a diagnosis, predicting a prognosis, selecting a suitable treatment method, monitoring the response to treatment, and supporting future research. For these reasons, when hemato-oncological cancer is diagnosed, it's highly recommended by the guidelines, the karyotyping of cancer cells from bone marrow (Swansbury, 2003), (Wan, 2017).

Conventional cytogenetics of primary tumor cells are associated with difficulties in the culture of these cells, low mitotic index and poor chromosome morphology, which results in complications in detecting abnormalities below 5 Mb. However, the technique of molecular cytogenetics, FISH, has complemented conventional cytogenetics, by allowing, the detection of chromosomal anomalies not detected through karyotype, and the detection of genes involved in carcinogenic processes, when applied both in metaphases and/or nuclei in interphase. Therefore, FISH is also widely used in the establishment of diagnosis, prognosis and monitorization of hemato-oncological patients (Wan, 2017).

Hemato-oncological cytogenetics, as mentioned previously, also helps in the selection of therapeutic approaches, since the most appropriate therapy will be chosen based on the genetic aberration discovered. As a result, patients with genetic anomalies who have a good prognosis should receive a different sort of therapy than patients with genetic anomalies who have a poor prognosis (Wan, 2017).

Even during or after treatment in leukemia patients (for example), cytogenetic studies are important for patient follow-up since the appearance of chromosomal abnormalities is an indicator of disease progression.

However, the absence of an abnormal clone or the existence of a "normal" karyotype of an oncological malignancy does not imply a good prognosis, it's possible that the cells examined were not derived from the oncological cells, or simply, the genetic aberration was not observed.

4.1.3.1. Culture of Hematopoietic Cells from Bone Marrow and Peripheral Blood for Chromosome Analysis

The main objective of this technique is to discover and describe acquired somatic numerical and structural chromosomal rearrangements in hemato-oncological patients, but also to monitor patients during treatment or bone marrow transplants.

PRE-ANALYTICAL PHASE

Sample acceptance

Bone marrow and peripheral blood samples are accepted every workday except Friday. The samples are brought to the laboratory in tubes containing sodium-heparin and kept at room temperature until cultivated.

The amount of bone marrow and peripheral blood cultured is determined by the degree of cellularity of the sample, with more sample being added in cases of low cellularity. Normally, this count is carried out by the colleagues from the hemato-oncological cytomorphology laboratory. In the absence of this information, a standard amount of 1ml is added to the culture medium.

ANALYTICAL PHASE

Culture of hematopoietic cells

The cell culture is carried out under aseptic conditions inside the laminar flow chamber.

Depending on the amount of sample available, 1 or 2 cultures are performed for each bone marrow and peripheral blood sample. In general, 1 ml of the specimen is placed with 5 ml of RPMI 1640 complete medium, which includes ultraglutamine, antibiotic, and 20% FBS. The culture medium should be filtered before the first use and then stored at 4°C.

Culture tubes should be labelled with the internal laboratory code for the sample in question, the patient's name, and the date the culture began.

For 24 hours, culture tubes are placed horizontally in a thermostat set to 37°C. They can sometimes be left for 48 to 72 hours if there is a weekend or holiday following the beginning of the culture. The ideal time, however, is 24 hours, because bone marrow has mitotically active cells. Maintaining extended cultures is not recommended because any cancer cells present may be lost.

The rest of the bone marrow samples are kept 4°C in a facility designated for "biological samples storage" until cases are analysed, concluded, and reported. When the case is completed, they are then disposed of in the hazardous biological waste container.

The "Cyto-Onco Traceability" file contains information about the culture media used, the dates, and the name of the cell culture operator.

Approximately, 24 hours after starting the culture, 120 µl of Syncroset A solution (Euroclone) is added, staying overnight, then, in the next day morning, 120 µl of Syncroset B (Euroclone) solution is added. Finally, after 5h, 30 µl of colcemid is added up to the cultures, and incubated for 1 hour, resulting in the cells being blocked at the metaphase stage. These steps are very similar to the ones performed on the culture of peripheral blood lymphocytes for chromosome analysis (explained previously).

Hypotonic solution

After the colcemid time has ended, the tubes are centrifuged at 1500 rpm for 5 minutes. The supernatant is then removed, and the pellet is resuspended in 4 ml of

hypotonic solution (pre-warmed to 37°C in the thermostatic bath) for 10 minutes, during this period, the tubes containing the samples are immersed in a thermostatic bath at 37°C.

Fixation

After 10 minutes of the hypotonic solution, samples are centrifuged for 5 minutes at 1500 rpm. The supernatant is then withdrawn, and the pellet is resuspended using the vortex while 4 ml (approximately) of fresh fixative solution (3:1 of methanol and acetic acid, respectively) is added drop by drop.

Before spreading the samples, the pellets are washed three times with a fixative solution until a clear solution is obtained. The washes, in which the supernatant is removed, and the pellet is burst, are intercalated with a centrifugation at 1500 rpm for 5 minutes. After the final centrifugation, the cells in the pellet are suspended in around 0.5 to 1.5 ml of fixative solution, depending on the volume of the pellet; the more pellet, the more fixative.

Spreading

Samples spreading is performed in the laminar flow chamber before being placed in the temperature and humidity-controlled incubator to dry. At least two slides are spread for each case, and the slides are labelled with the case code, the patient's name and the date of the spread.

Staining

Slides are stained by immersing them in a quinacrine mustard solution for at least 10 minutes. After 10 minutes, the slides are washed twice in distilled water and then one last time in McIlvaine buffer. The buffer excess on the slide is utilized to mount the coverslip. After that, the slide is dried and varnished. The microscope analysis can begin after the sample has dried.

Sample analysis: image acquisition, metaphase analysis, karyotype construction, and results interpretation.

Fluorescence microscopy allows us to acquire images from the best metaphases, while the informatic analysis software assists us in the construction of karyotypes and analysis of the chromosomes.

The files containing the acquired metaphases and constructed karyotypes also include the following information: name, surname and birth date of the patient, case code, indication of the exam, tissue examined, date of the image acquisition by the operator, date of the beginning of cell culture, number of metaphases examined, result (karyotype), and date of the exam conclusion.

Biologists are in charge of the analysis of the samples. Per case, 20 metaphases should be analysed and karyotyped, with a minimum of 10. It is not necessary to have a minimum resolution of the bands in oncologic cytogenetics, as it is in conventional cytogenetics, since these metaphases are usually of low quality, consequently, it is critical to analyse all metaphases.

Individuals transplanted with individuals of the opposite sex are also indicated for karyotype study, to monitor the success of the transplant. In these cases, a total of 100 metaphases are examined, 5 of which are karyotyped. Since the goal is to determine whether or not the transplant was successful, if all of the cells are of the donor sex, it means it worked. However, if the donor and recipient are of the same sex, the investigation is only carried out if a chromosomal abnormality was present at the start of the disease, to see if the abnormal cell lineage with the genetic abnormality was still present after the transplant, in this case, 20 metaphases are examined.

In cases of follow-up, after treatment or in remission, the following strategy should be taken into account: (Hastings, Howell, Dagna, Kristoffersson, & Cavani, 2012)

- If a normal result is obtained at diagnosis, no further analysis is required.
- If an abnormal result is obtained at diagnosis, a minimum of 20 metaphases should be analysed for the previously diagnosed abnormality, in addition to any secondary abnormality discovered. In some cases, it may be preferable to perform this follow-up with FISH or another molecular method.

- For post-transplant samples, a minimum of 20 metaphases should be analysed for the presence or absence of any distinctive karyotypic characteristic to differentiate donor cells from recipient cells, such as the Y chromosome in opposite-sex transplants. FISH can alternatively be performed with the analysis of at least 100 nuclei.
- For samples of suspected relapse, at least 20 metaphases should be analysed.

Each sample is analysed in accordance with the SIGU and ECA recommendations.

POST-ANALYTICAL PHASE

Final report

The final report is the responsibility of the lead biologist.

The following information should be included in the final report: full name of the patient, date of birth, type of sample analysed, date of sample entry in the laboratory, code of the sample, indication for the test, the name of the physician who prescribed the test, date of the report, name and signature of the person who completed the final report and also the signature of the laboratory director.

In addition, it should also contain, the culture and banding technique used, the number of metaphases acquired and karyotyped, and the final karyotype.

Reports must be concise and objective, reporting any limitations of the methodologies utilized as well as any uncertainty in the results. It is recommended to include information on the potential clinical effects of the genetic abnormality in issue. Finally, reports must be delivered within 28 days of the sample's delivery; in urgent instances, they must be supplied within 7 days (Rack, van den Berg, Haferlach, & al., 2019).



Area Aggregazione Servizi e Laboratori Diagnostici
U.O.C. Laboratorio di Genetica Umana
 Certificazioni ISO9001:2015 e SIGU CERT
 Direttore Dott. Domenico Coviello

CARIOTIPO DA COLTURA DI CELLULE EMOPOIETICHE
 Genova

Cognome e Nome: _____
 Codice Lab: _____
 Luogo e data di nascita: _____ Sesso: _____

Inviato da: CFS93 - Assistenza Semi Intensiva COVIDFREE 19
 Ospedale: IRCCS G. GASLINI - Genova
 Indicazione all'indagine: LLA infant esordio
 Data accettazione campione: 24/11/2021
 Materiale esaminato: Midollo Osseo

Tecnica di coltura: 24h non stimolata
 Bandeggio: QFQ
 Risoluzione bande: 300-350
 N° metafasi analizzate: 20
 N° metafasi cariotipate: 14
 Cariotipo: 46,XX,t(4;11)(q21;q23)[7]/46,XX[13]

Commento: Si evidenzia un clone cellulare con cariotipo femminile pseudodiploide a 46 cromosomi con traslocazione reciproca apparentemente bilanciata tra le braccia lunghe dei cromosomi 4 e 11 con rotture alle bande 4q21 e 11q23. Cariotipo femminile normale in tredici metafasi.

Dirigente del Settore _____ Per il Direttore _____

Figure 25 – Example of a final karyotype report of hematopoietic cells derived from a bone marrow sample

4.1.4. Clinical Cases

I described two clinical cases, as examples, to understand the laboratory strategy used for each case and the interpretation of the results.

Case 1

Name: Luísa Dias *

Date of birth: 17/02/2021

Sex: Female

Clinical Indication: Suspect of Infant Acute Lymphoblastic Leukemia (ALL-Infant)

Girl, 1-year-old, suspected of having infant acute lymphoblastic leukemia.

When this girl began to be followed clinically, routine blood tests were carried out, which demonstrated the levels of white blood cells (WBCs) very high and the levels of hemoglobin very low. Therefore, a cytomorphological examination was performed, first with a sample of peripheral blood, in which a percentage of 81% of blasts were found,

leading to suspicion of ALL. Then, a bone marrow sample was also analysed by cytomorphology, which showed a presence of 85% of blasts. Posteriorly, cytogenetic analysis of the bone marrow was requested.

Methodology

- Conventional cytogenetic analysis of hematopoietic cells cultured from bone marrow samples, metaphase spreading and QFQ banding.

Analysis and Interpretation of Results

After the acquisition of the 20 metaphases, all of them were analysed and it was possible to karyotype 14 of them. Was found a reciprocal translocation, apparently balanced between the long arms of the chromosomes 4 and 11, in 7 of the metaphases analysed. The remaining 13 metaphases had a normal female karyotype.

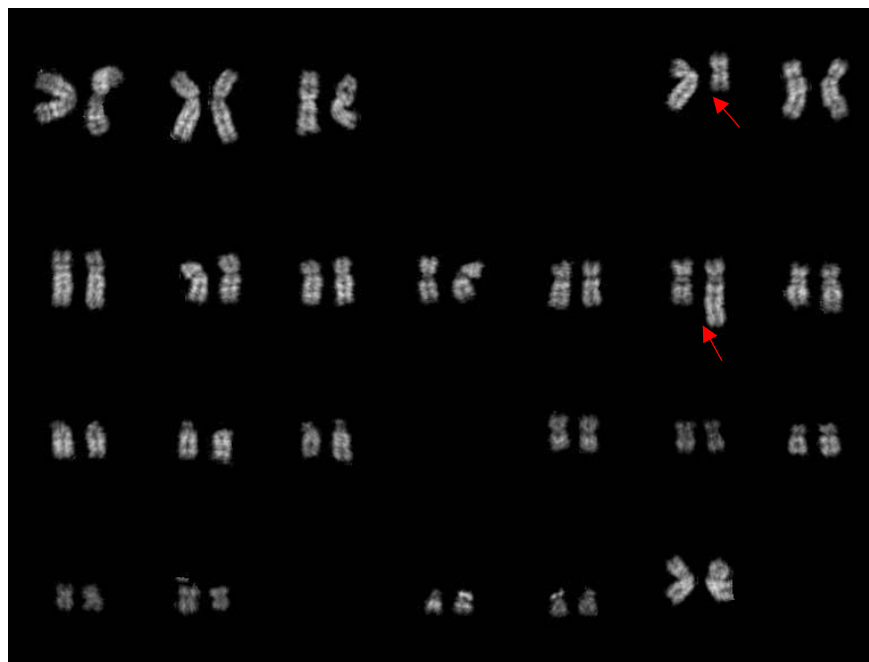

Figure 26 – Luísa's bone marrow karyotype (image provided by the laboratory of human genetics of institute Giannina Gaslini).

Leukemia

Leukemia is the most frequent type of childhood cancer. It's caused by the excessive proliferation of aberrant hematopoietic cell clones, which disrupts normal bone marrow function, leading to bone marrow failure. This disease can be divided into several types,

according to how quickly it develops and how severe it is. It can be acute leukemia, characterized by its rapid progression, or chronic leukemia, characterized by slow disease growth. These types of leukemia can still be classified according to the type of WBCs affected, it can arise from cells of the myeloid or lymphoid lineages (Seth & Singh, 2015).

Infant Acute Lymphoblastic Leukemia

Infant-ALL (infants less than 12 months of age) is a very aggressive cancer with a high risk of relapse and poor outcome. It's characterized by the accumulation of malignant, immature lymphoid cells (lymphoblasts) in the bone marrow and peripheral blood. Can be classified as B-lineage ALL or T-lineage ALL, that is, whether it is caused by a cancer transformation at the level of the B-lymphocytes or the T-lymphocytes (Heim & Mitelman, 2015).

The cause of this condition is unknown in most cases, however, several genetic disorders, like Down syndrome, increase the risk of developing ALL. It can also be caused by chromosomal anomalies, like translocations that produce fusion genes that will encode a protein with oncogenic potential. The most prevalent anomalies that confirm the diagnosis of ALL include: $t(8;14)(q34;q32)$, $t(12;21)(p13;q22)$, and **$t(4;11)(q21;q23)$** (Heim & Mitelman, 2015), (Seth & Singh, 2015).

Genetic abnormalities discovered in the aberrant cells of ALL patients have a significant impact on the therapy chosen and the disease's prognosis. Some abnormalities relate to a better prognosis, while others are associated with a worst prognosis. For example, the presence of hyperdiploidy (number of chromosomes bigger than 50 ($n>50$)) is connected with a more favourable prognosis, whereas the presence of hypodiploidy (number of chromosomes fewer than 45) is associated with a poor prognosis (Seth & Singh, 2015).

Conclusion

In the case of this girl, where the $t(4;11)(q21;q23)$ was found in her bone marrow cells, a diagnosis of Infant-ALL can be made immediately, since this translocation is consistently associated with ALL. This translocation leads to a fusion of the *MLL* gene and the *AFF1* gene, generating the *MLL-AFF1* fusion gene, which is associate with an unfavourable prognosis, since affected infants tend to have more resistant disease and a higher risk of relapse (Seth & Singh, 2015), (Guest & Stam, 2017)

Final Karyotype: 46,XX,t(4;11)(q21;q23)[7]/46,XX[13]

* The names used in the clinical cases are fictitious.

Case 2

Name: Mariana Pereira

Date of birth: 02/04/2003

Sex: Feminine

Clinical Indication: Suspect of Chronic Myeloid Leukemia (CML)

Girl, 19 years old, was diagnosed with CML.

Methodology

- Conventional cytogenetic analysis of hemopoietic cells cultured from bone marrow samples, metaphase spreading and QFQ banding.

Analysis and Interpretation of Results

After the acquisition of the 20 metaphases, all of them were analysed and 12 were karyotyped. The analysis showed a reciprocal translocation, apparently balanced between the long arms of the chromosomes 9 and 22, in 8 of the metaphases analysed. The remaining 12 metaphases had a normal female karyotype.

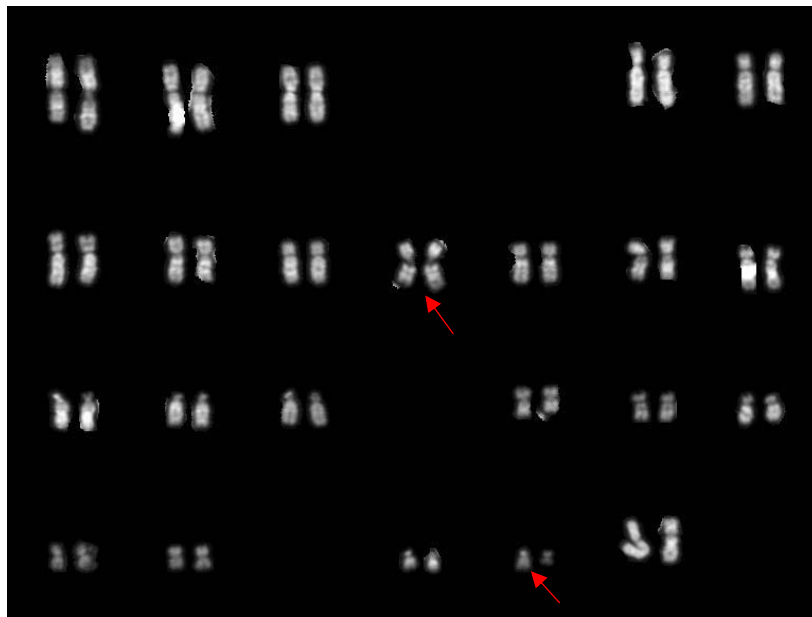

Figure 27 – Mariana's bone marrow karyotype (image provided by the laboratory of human genetics of institute Giannina Gaslini).

Chronic myeloid leukemia

CML is a myeloproliferative neoplasm that can be caused by the translocation t(9;22), commonly known as the Philadelphia chromosome, which originates a fusion gene between the *ABL1* gene located on chromosome 9 with the *BCR* gene located on chromosome 22. This results in the expression of the oncoprotein BCR-ABL1, which has a constitutive tyrosine kinase activity that will promote uncontrolled growth and replication (Jabbour & Kantarjian, 2018).

The disease can be classified into three phases: the earliest, chronic phase (CP), accelerated phase (AP) and the last and most severe, the blast phase (BP). Most patients are diagnosed in the earliest CML-CP phase by mistake, i.e., through routine medical examinations or blood tests, as most of these patients still have no symptoms at this stage (Jabbour & Kantarjian, 2018), (Baccarani, et al., 2013).

Diagnosis is made by unexplained persistence of leukocytosis and/or the presence of the Philadelphia chromosome (t(9;22)(q34;q11)) found by cytogenetic analysis, FISH or molecular studies (Jabbour & Kantarjian, 2018).

Usually, the Ph chromosome is present in 100% of the studied metaphases as a single abnormality, however, there is a small fraction of these patients, who have additional chromosomal abnormalities (clonal evolution), such as trisomy 8, isochromosome 17, etc., (Jabbour & Kantarjian, 2018).

Conclusion

The presence of the Ph chromosome is sufficient to diagnose CML, so this girl can start treatment, for example with a tyrosine kinase inhibitor (TKI) like imatinib (Gleevec), which will act by reducing the production of abnormal WBCs. About 70% of the affected individuals who take this treatment, in about 1 year have a complete cytogenetic response (CCyR). However, after starting treatment, patients should be monitored to verify the response and efficacy of treatment by blood counts, molecular and/or cytogenetic analyses, 3 months after the start of the treatment and then every 3 to 6 months after (Treating Chronic Myeloid Leukemia by Phase, 2021).

Final Karyotype: 46,XX,t(9;22)(q34;q11)[8]/46,XX[12]

4.2. Prenatal Screening and Diagnostic

Every pregnancy carries a risk of producing a fetus with chromosomal and/or genetic abnormalities. A large proportion of miscarriages and congenital abnormalities are the result of chromosomal anomalies, such as aneuploidies, in which most of them are not even observed because the miscarriage happens at a very early stage, however, in others, the pregnancy can continue, more specifically, trisomies 13, 18 and 21 (Patau's syndrome, Edwards syndrome, and Down syndrome, respectively). The etiology of these events (aneuploidies) is related to meiotic/mitotic nondisjunctions, with most of these having maternal origin (Ashfield, et al., 2021), (Prenatal Screening and Diagnostic Testing for Fetal Chromosomal and Genetic Conditions).

Non-invasive Prenatal Screening

Non-invasive prenatal screening tests are offered to all pregnant women. It allows the identification of high-risk pregnancies for chromosomal abnormalities and/or malformations, helping in the decision about whether to carry out an invasive prenatal diagnosis or not. These tests must be performed voluntarily after the pregnant woman has been informed about the entire procedure and the possible outcomes. These types of screening tests include biochemical testing, fetal ultrasound and non-invasive prenatal testing (NIPT), they are performed using maternal peripheral blood samples and/or ultrasound imaging (Ashfield, et al., 2021), (Prenatal Screening and Diagnostic Testing for Fetal Chromosomal and Genetic Conditions).

First-trimester prenatal screening is ideally performed between the 11th and 13th week of pregnancy and is based on measuring the levels of certain analytes, such as pregnancy-associated plasma protein A (PAPP-A) and hCG (human chorionic gonadotropin) present in the maternal blood in combination with ultrasound scanning, where they evaluate the nuchal translucency, etc. The quantity of these specific analytes will differ depending on whether or not the fetus is a carrier of an abnormality. Ultrasound can determine the gestational age, the presence of multiple pregnancies, and the viability of the fetus. If a malformation is suspected or confirmed through an ultrasound, the possibility of prenatal diagnosis should be offered. If the abnormality is incompatible with life, the couple can

be offered the option of medical termination of the pregnancy, until the 24th week of pregnancy, after genetic counselling. A second-trimester screening test with the measuring of different analytes combined with an ultrasound for the search of fetal structural defects can also be conducted, between 18th and 22th weeks of gestation (Ashfield, et al., 2021), (Audibert, et al., 2017), (Rose, et al., 2020).

Another more recent non-invasive prenatal screening test available, the most sensitive and specific, is NIPT, which allows pregnant women to screen for the most prevalent aneuploidies using NGS sequencing of cell-free fetal DNA (cffDNA) found in the maternal plasma. A positive NIPT result should be followed by an invasive diagnostic test to confirm it (Ashfield, et al., 2021).

Prenatal Diagnostic

Invasive diagnostic genetic tests can be of two types: amniocentesis or chorionic villus sampling, which can be used to determine a chromosomal or genetic problem in a fetus, by the study of amniotic fluid or chorionic villi cells. However, a negative screening test result doesn't ensure that the fetus will not have any other genetic disease (Rose, et al., 2020).

While screening is offered to all pregnant women, invasive diagnostic testing for chromosomal/gene abnormalities is recommended for only a subset of women, since these procedures include a small risk of miscarriage (Prenatal Screening and Diagnostic Testing for Fetal Chromosomal and Genetic Conditions).

Clinical indications for prenatal invasive diagnostic testing are: (Ashfield, et al., 2021), (Audibert, et al., 2017).

- Advanced maternal age (>35 years old)
- Positive biochemical screening
- Positive parental carrier test
- Abnormal ultrasound (i.e., increased nuchal translucency)
- Positive NIPT
- Family history of chromosomal abnormality
- Couples with previous live-born/stillbirth with a chromosomal alteration
- History of congenital anomalies or recurrent miscarriages (≥ 3) of unknown etiology

There are several types of tests, from cytogenetic to molecular, that can be performed in prenatal diagnosis, for example, FISH, QF-PCR (Quantitative Fluorescent-PCR), conventional cytogenetics, Array-CGH, among others (Ashfield, et al., 2021).

Because prenatal cytogenetic analysis can take up to two weeks, in urgent circumstances, QF-PCR or FISH, can be performed immediately to detect the most frequent aneuploidies, with results available in only two days. They are usually performed when there is a positive screening result or when there are fetuses with ultrasonography defects. The results of these fast tests should be subsequently validated with karyotype (Ghi, et al., 2016).

Amniocentesis

Amniocentesis refers to the transabdominal aspiration of amniotic fluid from the uterine cavity. Should be performed from 15-18 weeks of gestation. The risk of fetal loss associated with amniocentesis is 0.1% to 0.5%, depending on the experience of the centre. Amniotic fluid cells are cultured for about 2 weeks before being analysed. Uncultured amniotic fluid can also be used for fast screening for the most common numerical chromosomal abnormalities with FISH with specific probes for chromosomes 13, 18 and 21 and sex chromosomes X and Y (Ghi, et al., 2016), (Levy, 2019).

Chorionic villus sampling

Chorionic villus sampling (CVS) refers to the withdrawal of trophoblastic cells from the placenta, it should be performed around 10-12 weeks of gestation. The risk of fetal loss associated with CVS is 0.2% to 1%. Compared with amniocentesis, the advantage of the CVS is that provides results at an early gestational period, offering more time for parental adjustment and/or decision-making, however, in CVS there is a greater likelihood of ambiguous results, since around 1% of samples, obtained by this method, present confined placental mosaicism (CPM). In these cases, it is indicated to perform amniocentesis, to differentiate true fetal mosaicism from CPM. These situations should be avoided, since we are exposing the pregnant woman again to the risk of fetal loss (Ghi, et al., 2016), (Levy, 2019).



Sampling procedure		
Getational weeks	10-12 [^]	15-18 [^]
Different type of tissues used for prenatal diagnosis	<p>Corionic Villi First trimester</p> 	<p>Amniotic Fluid Second trimester</p> 

Figure 28 - Prenatal diagnosis sampling (amniocentesis and CVS) (image provided by the human genetics laboratory of the institute Giannina Gaslini).

Fetal karyotype from cells of amniotic fluid

This method is usually carried out with the following indication:

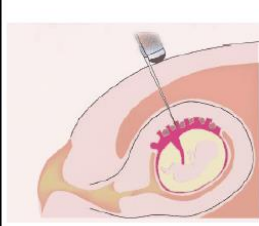
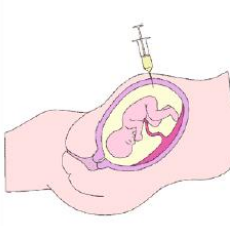
- Search for aneuploidies of the autosomes
- Search for aneuploidies of sex chromosomes
- Identification and characterization of small supernumerary chromosomes (markers)
- Identification and characterization of structural chromosomal rearrangements: reciprocal translocations, Robertsonian translocations, inversions, duplications, deletions and/or insertions

Very briefly, the process has the following phases:

It starts with the culture of the amniotic fluid samples. After about 2 weeks, the processing of the samples starts, with the blocking of the cells in metaphase, followed by placement of hypotonic solution, fixation of the chromosomes and finally, before the microscopic analysis, colouring of the chromosome bands. During the microscopic analysis, the metaphases are acquired, the karyotypes are reconstructed, and the results are analysed and interpreted. The final report is then written. The practical part is carried

out by the laboratory technicians, while the microscopic analysis and the report are carried out by the biologists in charge.

Fetal karyotype from cells of chorionic villus

The methodology is very similar to that of amniotic fluid. It has the same study indications but can be performed in the 1st trimester of pregnancy.

One of the differences in relation to the karyotype study in amniotic fluid is that, the sample obtained by CVS can be divided into 2 different aliquots: the first aliquot is used for the short-term culture (24h), also known as direct method, that allows the direct visualization of metaphases, while the second aliquot is used for the long-term culture (in which the protocol is the same as in amniotic fluid). Thus, in the direct method, the aim is to obtain a quick result that must then be confirmed with the long-term culture method.

4.2.1. Non-Invasive Prenatal Genetic Testing (NIPT)

NIPT is a prenatal screening that is highly sensitive and specific for the identification of the most common aneuploidies: trisomy 21 (Down syndrome), 18 (Edward's syndrome), and 13 (Patau's syndrome), as well as the sexual chromosome aneuploidies, based on the detection of cfDNA present in the maternal blood and that derives from the chorionic villi cytotrophoblasts (Hartwig, Ambye, Sørensen, & Jørgensen, 2017), (Gregg, Skotko, Benkendorf, & al., 2016).

Although NIPT can identify some disorders caused by copy number variations (CNVs), such as DiGeorge syndrome, Prader-Willi syndrome, between others, due to its limited sensitivity, the laboratory only performs NIPT for the most frequent aneuploidies (autosomes and sex chromosomes), as recommended by the national and international guidelines (Ministero della Salute, 2015), (Dondorp, de Wert, Bombard, & al., 2015).

The diagnostic techniques now in use for prenatal diagnosis of chromosomal abnormalities are invasive diagnostic genetic testing done either on chorionic villus sampling or amniotic fluid, followed by karyotype, FISH and/or Array-CGH analysis. However, these procedures involve a small risk of miscarriage, therefore, NIPT is a viable alternative for parents who wish to know their pregnancy risk for the most frequent aneuploidies without putting the fetus at danger of miscarriage (Alberry, Aziz, Ahmed, & Abdel-Fattah, 2021).

NIPT is classified as a screening test rather than a diagnostic test because, despite its high sensitivity, there is a tiny possibility of false negatives or false positives. It should also be emphasized that the fetal DNA that will be tested comes from chorionic villi, therefore it may not always be representative of the fetus genotype, for example, in situations of CPM, compromising the NIPT result. When a positive NIPT result is obtained or CPM is suspected, an invasive diagnostic genetic test (amniocentesis) should be conducted to confirm the diagnosis (Hartwig, Ambye, Sørensen, & Jørgensen, 2017), (Gregg, Skotko, Benkendorf, & al., 2016).

NIPT can be carried out at any point in the pregnancy, from 10th week of gestation onwards, to increase the likelihood of sufficient fetal fraction (FF), since around this time the FF present in the maternal peripheral blood is of approximately 10%. The fetal fraction is the quantity of cfDNA divided by the total amount of free DNA, and it, if low

can affect the test's sensitivity (Alberry, Aziz, Ahmed, & Abdel-Fattah, 2021), (Hartwig, Ambye, Sørensen, & Jørgensen, 2017), (Harraway, 2017).

NGS is used in NIPT. The first step is the collection of maternal peripheral blood in special tubes (Streck tubes) to avoid losing any free DNA present in the maternal blood, and then the plasma is isolated to extract the cffDNA. The second step is the library preparation, including the samples quantification, and the run for sequencing. Finally, the resulting data is analysed by a specific software for cffDNA quantification (Curnow, Sanderson, & Beruti, 2019).

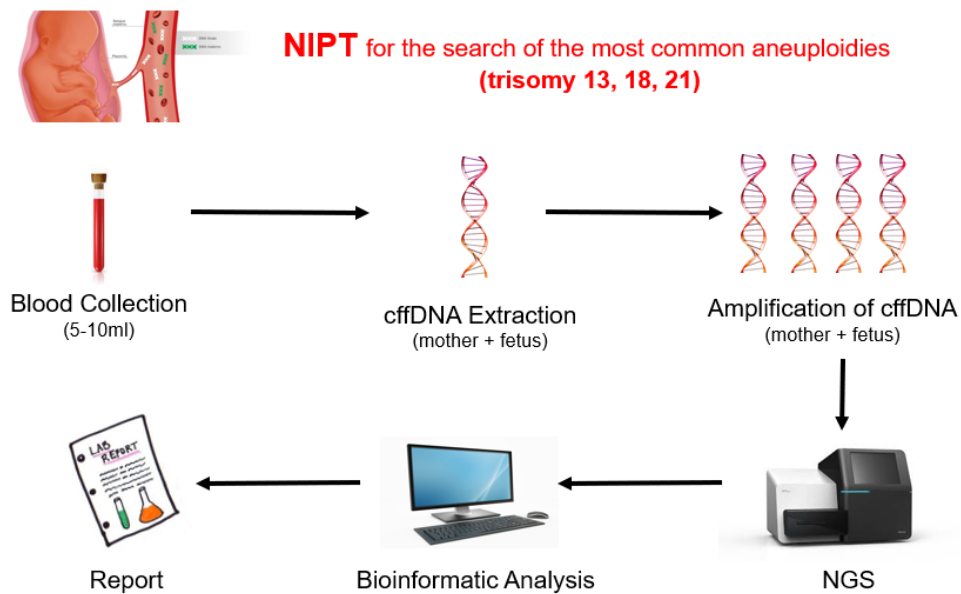

Figure 29 - Flowchart of NIPT.

4.3. Case Report – Interstitial 2q24.2q24.3 Microdeletion: Two New Cases with Similar Clinical Features Except for Profound Deafness.

During my stay in the postnatal cytogenetics laboratory, I had the opportunity to participate in the publication of a case report.

In this case report, we described the cases of two patients with overlapping *de novo* microdeletions located in the region 2q24.2q24.3. Both patients had very similar characteristics, except that one of them presented profound deafness. In the article, we also discussed the role of the genes located in the deleted region.

Cytogenetic
and Genome
Research

Novel Insights from Clinical Practice

Cytogenet Genome Res
DOI: 10.1159/000525181

Received: September 7, 2021
Accepted: April 28, 2022
Published online: July 27, 2022

Interstitial 2q24.2q24.3 Microdeletion: Two New Cases with Similar Clinical Features with the Exception of Profound Deafness

Elisa Tassano^a Sara Uccella^{b,c,d} Patrizia Ronchetto^a Joana Soraia Martinheira Da Silva^{a,h}
Silvia Viaggi^{a,i} Margherita Mancardi^c Luca Ramenghi^d Alessandra Murri^e Marina Biondi^f
Giorgio Gimelli^g Cristina Morerio^a Michela Malacarne^a Domenico Coviello^a

^aLaboratory of Human Genetics, IRCCS Istituto Giannina Gaslini, Genoa, Italy; ^bDepartment of Medical and Surgical Neuroscience and Rehabilitation, University of Genoa, Genoa, Italy; ^cChild Neuropsychiatry Unit, IRCCS Istituto Giannina Gaslini, Genoa, Italy; ^dNeonatology Unit, IRCCS Istituto Giannina Gaslini, Genoa, Italy; ^eUnità Operativa di Otorinolaringoiatria, Ospedale Guglielmo da Saliceto, Piacenza, Italy; ^fUnità Operativa di Radiologia, Ospedale Guglielmo da Saliceto, Piacenza, Italy; ^gLaboratory of Cytogenetics, IRCCS Giannina Gaslini, Genoa, Italy; ^hFaculty of Medicine, University of Coimbra, Coimbra, Portugal; ⁱDISTAV, University of Genoa, Genoa, Italy

© Free Author
Copy - for per-
sonal use only

ANY DISTRIBUTION OF
THIS ARTICLE WITHOUT
WRITTEN CONSENT
FROM S. KARGER AG,
BASEL IS A VIOLATION
OF THE COPYRIGHT.

Written permission to
distribute the PDF will be
granted against payment
of a permission fee,
which is based on the

Figure 30 – Article cover “Interstitial 2q24.2q24.3 Microdeletion: Two New Cases with Similar Clinical Features with the Exception of Profound Deafness”

Clinical Report

Patient 1

Patient 1 is an 11-year-old girl, without a family history of genetic disorders. This girl started to be followed clinically, due to suspicion of epileptic absences, however, since, from the first year of life, she showed a neurodevelopmental delay, with the presence of

autistic traits, joint hyperlaxity and global hypotonia. In addition, she also presented some facial dysmorphisms.

Patient 2

Patient 2 is a 5-year-old girl, without a family history of genetic disorders. She was diagnosed at 3 months old with a bilateral profound sensorineural deafness due to a bilateral narrow internal auditory canal. Later, at the age of 6 months, it was discovered that she also possessed a patent foramen ovale with a left-right shunt at birth, in addition to a small posterior muscular ventricular septal defect observed with echocardiography. At the age of 17 months, the girl also showed a psychomotor delay, hypotonia, ligamentous hyperlaxity, divergent strabismus, various dysmorphisms and 2 small chest haemangioma.

Materials and Methods

Karyotyping was performed in peripheral blood samples from both patients and their parents, but nothing abnormal was found since the deletions were too small to be detected by cytogenetics.

Next, was performed an Array-CGH on DNA samples extracted from the peripheral blood of both the patients and their parents, in which a microdeletion was discovered in both the patients, in the same chromosomal region but with slightly different sizes. Subsequently, FISH was performed and confirmed the presence of this microdeletion in both patients. The parents of both patients were normal.

Results

The Array-CGH revealed that both patients had a heterozygous *de novo* interstitial deletion in the long arm of chromosome 2.

Patient 1 presented a 2.966-Mb deletion of chromosome 2, in the region 2q24.2q24.3, which contains 11 OMIM genes: *SLC4A10*, *DPP4*, *GCG*, *FAP*, *IFIH1*, *GCA*, *KCNH7*, *FIGN*, *GRB14*, *COBLL1* and *SLC38A11*.

Patient 2 presented a 3.795-Mb deletion of chromosome 2, in the same region, 2q24.2q24.3, containing 15 OMIM genes: *PLA2R1*, *ITGB6*, *RBMS1*, *TANK*, *PSMD14*, *TBR1*, *SLC4A10*, *DPP4*, *GCG*, *FAP*, *IFIH1*, *GCA*, *KCNH7*, *FIGN* and *GRB14*.

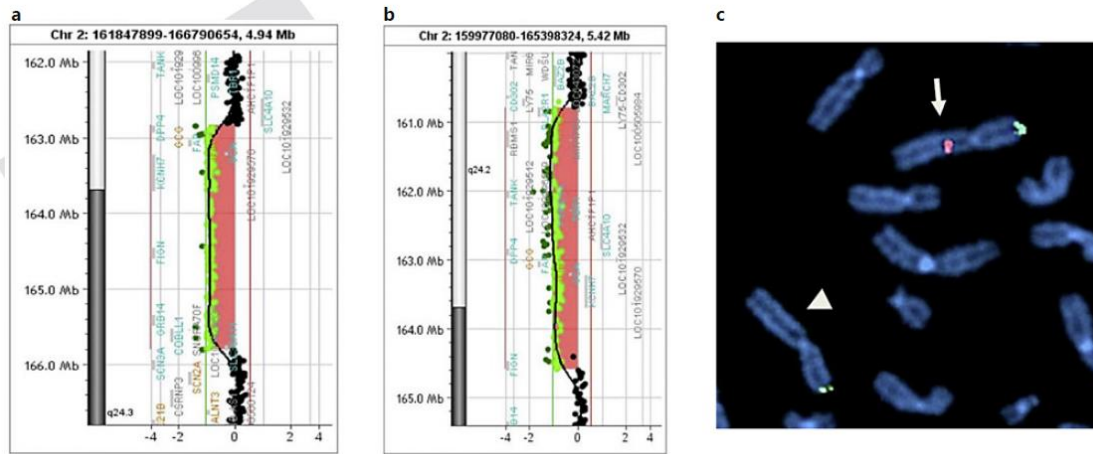

Figure 31 - Results of the Array-CGH and FISH analyses. **A)** Array-CGH of patient 1. **B)** Array-CGH of patient 2. **C)** FISH confirmation of the microdeletion present in both patients. (image taken from the article)

Interstitial 2q24.2q24.3 microdeletions are rare cytogenetic abnormalities that, depending on their size, are associated with heterogeneous clinical features.

Although these genes *SLC4A1*, *DPP4*, *GCG*, *FAP*, *IFIH1*, *GCA*, *KCNH7* and *FIGN*, are deleted in both patients, we focused our attention on the following ones, *SLC4A10*, *DPP4*, and *KCNH7*, since they are associated to neurological features.

Genes	OMIM	Deleted in patient 1	Deleted in patient 2
<i>PLA2R1</i>	604939		Del
<i>ITGB6</i>	147558		Del
<i>RBMS1</i>	602310		Del
<i>TANK</i>	603893		Del
<i>PSMD14</i>	607173		Del
<i>TBR1</i>	604616		Del
<i>SLC4A10</i>	605556	Del	Del
<i>DPP4</i>	102720	Del	Del
<i>GCG</i>	138030	Del	Del
<i>FAP</i>	600403	Del	Del
<i>IFIH1</i>	606951	Del	Del
<i>GCA</i>	607030	Del	Del
<i>KCNH7</i>	608169	Del	Del
<i>FIGN</i>	605295	Del	Del
<i>GRB14</i>	601524	Del	Del
<i>COBLL1</i>	610318	Del	
<i>SLC38A11</i>	616526	Del	

Genes in the overlapping deleted region are shown in bold.

Figure 32 – Genes present in 2q24.2q24.3 (chr2:160,790,267–165,802,103) deleted in patients 1 and 2 (image taken from the article)

Conclusion

The two patients had similar features, such as intellectual disability, developmental and language delay, hypotonia, joint laxity, and dysmorphism. Patient 2 was also a carrier of a heterozygous mutation on the *GJB2* gene responsible for the autosomal recessive deafness 1A. We cannot exclude the presence of a pathogenic variant in another known deafness gene. This discovery made us consider the possibility that the disruption of a gene present in the 2q24.2q24.3 deleted region could be co-responsible or involved in profound hearing loss.

There is not enough scientific information about these microdeletions and the associated phenotypes, only 7 case reports have been published. Therefore, more studies and cases are needed to better clarify the natural history of this condition.

P ART 2 – TRAINEESHIP REPORT

MOLECULAR GENETICS

1. Next Generation Sequencing

Next generation sequencing is a method that sequences simultaneously millions of DNA fragments, which allows the analysis of multiple genes or gene regions in a single test and in a short amount of time. One of the most significant benefits and clinical applications of NGS is its capacity to identify genetic variations between a DNA sample and a reference genome (Kanzi, San, Chimukangara, & al., 2020), (Muzzey, D., 2015), (Yohe & Thyagarajan, 2017).

NGS offers a wide range of applications from detecting germline (inherited) or acquired (somatic) variants through targeted panels, whole-exome sequencing (WES), whole-genome sequencing (WGS) or RNA sequencing. Targeted custom panels, for genes associated with a certain clinical phenotype, are usually done when the clinical diagnosis is well established, and the number of patients is quite relevant. On the other side, when dealing with a rare disease in which the clinical diagnosis is uncertain, it's preferable to perform WES, but with the analyse of only the group of genes related to the clinical symptoms (in silico panel). If the results are still inconclusive, the whole WES analysis or even WGS can be done (Yohe & Thyagarajan, 2017).

Generally, NGS starts with the DNA extraction from the samples to be analysed, followed by the preparation of the library, which can be done by hybridization capture or by amplicon sequencing.

Hybridization capture consists of the fragmentation of the DNA (mechanical or enzymatically), ligation of the adapters that include the barcodes (specific to each patient/sample and which allows the pooling), pooling of the samples, hybridization of the biotinylated probes with the specific DNA sequences, and purification and selection of the DNA target by the magnetic streptavidin beads (Gaudin & Desnues, 2018).

Amplicon sequencing comprises the DNA amplification by multiplex PCR using specific primers for the target regions, followed by a second PCR in which occurs the ligation of the adapters that include the barcodes, and at last, the samples are pooled and purified before sequencing (Kanzi, San, Chimukangara, & al., 2020), (Yohe & Thyagarajan, 2017), (Mardis, 2013).

Finally, we have the sequencing run. In the laboratory, they use two Illumina sequencers, Miseq and Nextseq550. The first step is to immobilize each DNA fragment and clonally amplify it, using a flow cell, which contains a sequence that will hybridise with the adapter present on each DNA fragment. These types of sequencers, use sequencing by synthesis with fluorescent detection. Fluorochrome-labelled modified nucleotides are utilized to sequence the DNA. Each nucleotide is represented by a distinct color. When the polymerase integrates a changed base into the chain, replication stops, and the color of this fragment corresponds to the last nucleotide incorporated. Laser excitation leads to a fluorescent emission that is recorded and can be directly mapped onto a DNA sequence (Muzzey, Evans, & Lieber, 2015), (Yohe & Thyagarajan, 2017), (Mardis, 2013).

After the sequencing is complete, the resulting data can be processed and analysed using a bioinformatic software. This software will filter the resulting reads for quality, amplicon size, and agreement between paired ends, and then will align them to the reference genome, comparing these two, to do variant annotation, based also on the international databases, which helps in the writing of the final report (Muzzey, Evans, & Lieber, 2015), (Yohe & Thyagarajan, 2017), (Mardis, 2013).

2. Fragile X Syndrome

Fragile X syndrome (FXS) is caused by the loss of function of the *FMR1* gene, since the presence of a repeated expansion of a CGG triplet (>200 repetitions) causes methylation of the gene promoter, resulting in its inactivation. Most inherited forms of mental retardation and clinical sign of autism can be also caused by this condition (Nussbaum, McInnes, Willard, & Hamosh, 2007), (Turnpenny & Ellard, 2017), (Salcedo-Arellano, Hagerman, & Martínez-Cerdeño, 2020), (Mila, Alvarez-Mora, Madrigal, & Rodriguez-Revenga, 2018).

FMR1 gene encodes the Fragile X Mental Retardation Protein (FMRP), which is necessary for the initial phases of development and throughout life. FMRP deficiency alters synaptic connections in neurons, resulting in FXS-specific symptoms (Nussbaum, McInnes, Willard, & Hamosh, 2007), (Turnpenny & Ellard, 2017), (Salcedo-Arellano, Hagerman, & Martínez-Cerdeño, 2020), (Mila, Alvarez-Mora, Madrigal, & Rodriguez-Revenga, 2018).

FXS gets its name from the appearance of the X chromosome in affected individuals, which has a "fragile site" in the region Xq27.3, where the chromatin has failed to condense correctly during mitosis (Nussbaum, McInnes, Willard, & Hamosh, 2007), (Turnpenny & Ellard, 2017), (Salcedo-Arellano, Hagerman, & Martínez-Cerdeño, 2020), (Mila, Alvarez-Mora, Madrigal, & Rodriguez-Revenga, 2018).

2.1. Phenotype

FXS patients have mild to severe mental retardation, learning difficulties, impulsive behavior, anxiety, hyperactivity, and attention deficit. The most common phenotypic characteristics are prominent ears, long face, postpubertal macroorchism and hyperextensible joints (Nussbaum, McInnes, Willard, & Hamosh, 2007), (Turnpenny & Ellard, 2017), (Salcedo-Arellano, Hagerman, & Martínez-Cerdeño, 2020), (Mila, Alvarez-Mora, Madrigal, & Rodriguez-Revenga, 2018).

2.2. Classification of *FMRI* alleles

The number of CGG triplet repeats in the general population is variable; a normal individual has between 6 to 44 repeats. Usually, every 9 to 10 CGG triplets are interrupted by an AGG triplet in normal alleles. The existence of AGG interruptions in the CGG triplet expansion is critical because it provides stability; without them, these alleles can develop into premutation when passed down to following generations.

Individuals with alleles between 45 and 54 are called intermediate (grey zone), meaning they are either stable or slightly unstable.

Alleles with "pre-mutation" will have 55 to 200 triplet repetitions. In these circumstances, the *FMRI* gene is still transcribed and translated, although with decreased FMRP protein synthesis and elevated mRNA levels. Pre-mutations are particularly unstable when passed from mother to offspring, and there is a danger that they will evolve into a full mutation during female gametogenesis, therefore, these women have a higher risk of having affected kids. Furthermore, carriers of the premutation are at risk of developing late neurological diseases such as fragile X-associated tremor/ataxia syndrome (FXTAS). Males have a higher risk than females. Around the age of 40, carrier women may suffer from fragile X-associated premature ovarian failure (FXPOI). As previously stated, whereas FXS results in a loss of *FMRI* gene function, diseases linked with premutation result in a gain of *FMRI* gene mRNA function (Nussbaum, McInnes, Willard, & Hamosh, 2007), (Turnpenny & Ellard, 2017), (Salcedo-Arellano, Hagerman, & Martínez-Cerdeño, 2020), (Mila, Alvarez-Mora, Madrigal, & Rodriguez-Revenga, 2018), (Monaghan, Lyon, & Spector, 2013).

Finally, affected individuals have the "full mutation," which involves more than 200 repeats of the CGG triplet, resulting in methylation of the *FMRI* gene promoter and, as a result, a shutdown in FMRP protein synthesis. Males with the complete mutation are always affected by FXS, whereas females are only affected up to 50% due to the random X-chromosome inactivation process. However, the severity of FXS may also be variable because of the presence of mosaicism, varying methylation levels of the full mutated gene, among other factors (Nussbaum, McInnes, Willard, & Hamosh, 2007), (Turnpenny & Ellard, 2017), (Salcedo-Arellano, Hagerman, & Martínez-Cerdeño, 2020), (Mila, Alvarez-Mora, Madrigal, & Rodriguez-Revenga, 2018), (Monaghan, Lyon, & Spector, 2013).

2.3. Mosaicism of FXS

De novo mosaicism is uncommon in the *FMRI* CGG triplet expansion region; however, expansion size or methylation mosaicism can occur. If mosaicism is present, variations between tissues tested can be detected. Depending on the degree of mosaicism, varying amounts of the protein FMRP are produced, altering the phenotype, although in general, these individuals are not as affected as those with a completely methylated mutation (Monaghan, Lyon, & Spector, 2013), (Saldarriaga, González-Teshima, Forero-Forero, Tang, & Tassone, 2021).

Some people with FXS exhibit size mosaicism, so they have cellular subpopulations with fully methylated mutations and others with unmethylated premutations. While some individuals with FXS show methylation mosaicism, cell subpopulations with one methylated full mutation allele and others with unmethylated alleles can cover the whole size range from normal to full (Monaghan, Lyon, & Spector, 2013), (Saldarriaga, González-Teshima, Forero-Forero, Tang, & Tassone, 2021).

The inability to detect mosaicism, and therefore the probable failure to detect complete mutations, leads to difficulties in the evaluation of risks for FXS, FXTAS, and FXPOI.

2.4. Diagnosis of FXS

Following the detection of a CGG triplet expansion, the number of repetitions and the methylation profile of the *FMRI* gene promoter must be determined. FXS is diagnosed using a variety of approaches.

Traditional Southern Blot was considered the gold standard. PCR only, for example, has difficulty finding full mutations owing to the CGG triplet expansion area, but can frequently detect pre-mutations. As a result, it is difficult to distinguish between women who are homozygous for a normal allele, and women who have a second allele with a full mutation but has not been amplified using this approach. It also does not detect mosaic patients for premutations and complete mutations (Monaghan, Lyon, & Spector, 2013).

In the instance of the human genetics laboratory, RP-PCR (repeat primed-polymerase chain reaction) and mPCR (methylation-sensitive polymerase chain reaction) are typically used together to detect allele size and methylation.

The RP-PCR molecular genetic test is performed on the CGG triplet expansion region in the promoter of the *FMR1* gene, in the context of prenatal and postnatal diagnosis, on samples with the following clinical indications: FXS, intellectual deficit, FX-POI, FXTAS, autism, and familiarity for FXS, FXPOI, FXTAS and intellectual deficit (Istruzione Operativa 2.30).

RP-PCR will amplify the target DNA using two locus-specific primers (forward and reverse) that surround the target sequence and a third primer that hybridizes directly with the repeating sequence CGG, yielding a pool of amplicons that vary in size by one base. As a result, in addition to being able to observe the entire PCR product, it is also feasible to see a characteristic pattern that permits the identification of all potential genotypes linked with the disease in question, including mosaics (Istruzione Operativa 2.30), (Gu, et al., 2021). Because this pattern is made up of peaks, each of which represents a repeated unit (CGG), counting the number of peaks in the RP-PCR electropherogram may be used to estimate the number of CGG repetitions in a sample. In contrast to classical PCR, RP-PCR almost always identifies the presence of an expansion, regardless of its size. In the electropherogram, AGG breaks in the CGG repeats may also be seen (Istruzione Operativa 2.30), (Gu, et al., 2021).

In addition to the RP-PCR, the mPCR molecular test is performed in the laboratory to determine the methylation profile of the *FMR1* gene promoter for postnatal diagnosis in samples with the following clinical indications: FXS, intellectual deficit, autism, confirmation of a pre-mutation (promoter not methylated), or complete mutation (methylated promoter). This test can also be performed prenatally (Istruzione Operativa 2.31).

mPCR is a technique for analysing methylation patterns in which the target DNA is digested using a methylation-sensitive endonuclease, to select only the methylated DNA, such that if there is methylation, amplification occurs. This enables the visualization of the PCR product as well as the quantification of the degree of methylation of each amplified allele (Istruzione Operativa 2.31).

Prenatal testing for Fragile X syndrome is possible using amniotic fluid or chorionic villi samples. It should be noted that chorionic villi, by the time that the testing can be performed, typically lacks the methylation associated with the lyonisation process (inactivation of X) and may also lack the methylation associated with complete mutations, therefore, the methylation-sensitive approach is not recommended for prenatal diagnosis

at this stage. Most of the time, determining the extent of the expansion is enough to determine the genotype, and chorionic villus testing can assure and/or contemplate medical termination of pregnancy at an early stage of gestation. An amniotic fluid test may be recommended to confirm a premutation discovered in the chorionic villi and to identify or rule out the likelihood of somatic mosaicism with a full mutation (Biancalana, Glaeser, McQuaid, & Steinbach, 2015), (Monaghan, Lyon, & Spector, 2013).

Prenatal diagnosis should be offered to women with 55 repeats and above, for any pregnancy because the offspring have a high chance of expanding to full mutation. Some doctors also provide prenatal diagnosis to women who have a partner with a premutation, though expansion of a premutation from the father to a son is extremely rare. It should also be considered as a precautionary procedure in the case of a female pregnancy whose father has a complete mutation. Any family members of a carrier who may be at risk should also be offered prenatal diagnosis (Monaghan, Lyon, & Spector, 2013), (Biancalana, Glaeser, McQuaid, & Steinbach, 2015).

The identification of a complete mutation in a man is considered a diagnosis because it is 100% certain that he will present the disease, whereas in a woman, it can be both a diagnostic and a screening test because there is a random mechanism of X inactivation, and thus only half of the 50% of chromosomes X mutated will be active decreasing the risk of presenting the disease (Monaghan, Lyon, & Spector, 2013).

Because FXPOI or FXTAS do not have complete penetrance and depend on the size of the premutation and the age of the individuals, identifying a premutation is considered a predictive test (Monaghan, Lyon, & Spector, 2013).

2.5. Clinical Case

In this clinical case, we have the Ramos family (two generations), in which the daughter (proband) had a mild intellectual disability and was subsequently recommended to be tested for Fragile X syndrome, as were the parents.

The CGG triplet expansion of the *FMRI* gene was studied using the RP-PCR technique in both the proband and the parents (I-1 and I-2) in blood and saliva samples, to rule out mosaicism.

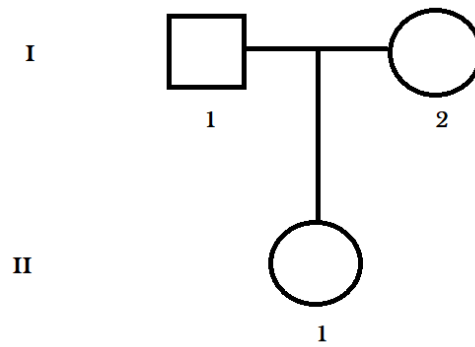

Figure 33 - Heredogram from the Ramos family (two generations).

Results - Family genotype

Genetic amplification of the DNA of the proband and parents, revealed the following information:

I-1 – $X^I Y$, (X^I = intermediate allele, 46 (± 2) CGG repetitions).

I-2 - $X^N X^N$, (X^N = normal allele, one X with 31 (± 1) and the other X with 30 (± 1) CGG repetitions).

II-1 - $X^N X^I$, (one X^N with 31 (± 1) repetitions inherited from the mom and one X^I with 46 (± 2) repetitions inherited from the father).

- Normal values: <45 CGG
- Intermediate values: 45-56
- Premutation: 55-200
- Full mutation: >200

Conclusion

Molecular examination of peripheral blood and saliva samples revealed the existence of the intermediate allele for the *FMRI* gene's repetitive sequence in heterozygosity in the daughter (proband).

Because intermediate alleles are not linked to Fragile X syndrome, the proband's minor intellectual deficiency cannot be attributed to the intermediate allele. Individuals bearing an intermediate allele, according to current knowledge, are not at danger of generating a full mutation expansion in the next generation, therefore the prognosis is optimistic, at least for the next generation.

AGG triplets were also investigated because they provide stability to the CGG triplet repeat, and two were discovered.

Monitoring of consecutive generations of the proband should be carried out to check if the intermediate allele expands or remains stable; if an increase occurs, future generations may be at danger of getting FXTAS, FXPOI, or even FXS.

Genetic counselling is advised for this family.

3. Cystic Fibrosis

Cystic fibrosis (CF) is the most frequent autosomal recessive illness in the Caucasian population (carrier frequency of about 1:25), caused by mutations in the *CFTR* (cystic fibrosis transmembrane conductance regulator) gene, which encodes the CFTR protein. This protein is an anion channel that transports chloride and sodium ions across the apical membrane of the epithelium of different tissues. Physiologically, when chloride exits the mucus-producing cells, it induces water to leave as well, making the mucus fluid. If the CFTR protein is not functioning correctly, CF patients develop thick, viscous mucus that obstructs the airways, resulting in respiratory difficulties (Rafeeq & Murad, 2017), (De Boeck, 2020), (Bell, Mall, Gutierrez, & al., 2020).

3.1. Phenotype

Cystic fibrosis typically affects numerous organs and therefore has a diverse phenotypic expression among persons with different severe *CFTR* mutations, most likely because of both environmental and genetic variables (modifier genes). The most severe form of CF is respiratory failure, which is the leading cause of mortality or lung transplantation in adults. The most prevalent digestive system problems include dietary deficits of mostly fat; diabetes; increasing hepatic dysfunction, among others. CF patients may also have male infertility, dehydration, among other symptoms (Rafeeq & Murad, 2017), (De Boeck, 2020), (Bell, Mall, Gutierrez, & al., 2020).

3.2. Classification of *CFTR* Gene Mutations

CFTR gene is found on chromosome 7 in the 7q31.2 region. More than 2000 mutations have been discovered as causing CF so far, the most frequent is the so-called F508del mutation (also known as $\Delta f508$, a deletion of 3 bases coding for phenylalanine at position 508) (Rafeeq & Murad, 2017), (De Boeck, 2020), (Bell, Mall, Gutierrez, & al., 2020).

Mutations in the *CFTR* gene are categorised based on the effect they have on the final protein:

- Class I mutations - result in the complete absence of the CFTR protein

- Class II mutations - result in defective processing and trafficking of the CFTR protein. F508del is the most frequent of these mutations, accounting for 70% of harmful alleles
- Class III mutations – result in abnormalities in protein regulation leading to decreased activity
- Class IV mutations – result in impaired conductance of the CFTR channel
- Class V mutations – result in a reduction in the amount of functional CFTR protein
- Class VI mutations – result in an unstable CFTR protein that is prematurely recycled from the apical membrane and degraded in lysosomes

Individuals with class I-III mutations have a more severe form of the illness (Rafeeq & Murad, 2017), (De Boeck, 2020), (Bell, Mall, Gutierrez, & al., 2020).

3.3. Molecular Genetic Diagnosis of Cystic Fibrosis

In Italy the NHS (National Health System) offers to all newborns the biochemical screening for CF, by the analysis of the quantity of immunoreactive trypsin in a sample of peripheral blood spotted on Guthrie card. If these levels are high, the result of the screening is positive, and then a genetic test is performed, in which the DNA is extracted from the same Guthrie card to perform the analysis for the most common variants causing CF (first level diagnosis).

There are many kits available to detect the most frequent pathogenic variants causing CF, however the sensitivity of variant panels differs depending on the ethnic/geographic origin of the individual under investigation, therefore they should be personalised to the group to which the patient under study belongs.

For example, in the laboratory, they use, as first level of analysis, the Devyser *CFTR* Core/Italy kit, which uses an allele-specific multiplex PCR to create a specific library for the identification of variants in the *CFTR* gene that are most common in the Italian population, which is then analysed by NGS. This technique can be used in peripheral blood samples, as well as chorionic villi or amniotic fluid samples (Bergougnoux, Taulan-Cadars, Claustres, & Raynal, 2018), (Bienvenu & Nguyen-Khoa, 2020), (Istruzione Operativa 2.57)., (Istruzione Operativa 2.57).

In addition, with NGS, it is also possible to analyse, in a second step, the *CFTR* gene complete coding area (exons) (Bienvenu & Nguyen-Khoa, 2020), (Bergougnoux, Taulan-Cadars, Claustres, & Raynal, 2018).

The results are analysed using Devyser's AmpliconSuite software, which filters the resulting data, in order to, only analyse the 362 most prevalent CF-causing mutations, and if nothing is identified, the whole area of the *CFTR* gene locus can be examined (Istruzione Operativa 2.40).

Only pathogenic and likely pathogenic mutations should be validated using Sanger sequencing or MLPA (Multiplex Ligation-dependent Probe Amplification) on the patient and, if available, parents samples (Istruzione Operativa 2.40).

Apart from neonates that are positive to the biochemical screening, a molecular test for cystic fibrosis is also recommended to individuals that exhibit typical illness symptoms, with a family history of the disease, such as an affected sibling, between others.

At last, a sweat test is normally conducted after a positive molecular analysis result for CF to confirm the clinical status. If the chloride concentration result in the sweat is above 60mmol/L, it indicates that the patient is affected by CF (De Boeck, 2020), (Bell, Mall, Gutierrez, & al., 2020).

3.4. Clinical Case

We have the case of two individuals diagnosed with cystic fibrosis where they have been characterized as compound heterozygotes and elected to start treatment with ETI (three-drug combination, elexacaftor/tezacaftor/ivacaftor), but the treatment turned out to be ineffective in both.

The ETI treatment restores the function of the aberrant protein, product of the pathogenic variants of the *CFTR* gene, such as the most common variant, F508del. For example, this treatment has shown very positive outcomes in clinical trials in patients with 1 or 2 copies of the F508del variant (Barry & Taylor-Cousar, 2021).

Individual 1 was initially characterised as compound heterozygous with the following genotype: F508del/G542X.

While individual 2 was initially characterised as being compound heterozygous with the following genotype: F508del/E585X

Therefore, both met the criteria for ETI therapy administration, but neither demonstrated a beneficial response to the treatment. So further research was carried out at a molecular level.

Results

The analysis of the cDNA of the *CFTR* gene, obtained by reverse transcription from the RNA extracted from the patient's sample was subsequently amplified and analysed using Sanger sequencing, revealing that both patients contained a third mutation, L467F, *in cis* with the F508del variant.

After studying the parents of each patient, it was verified how the segregation of the variants was carried out:

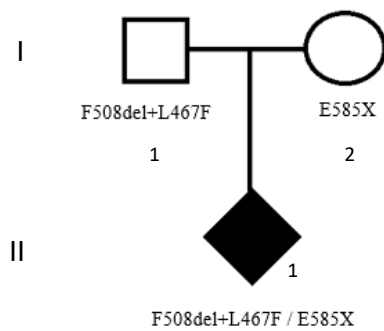

Figure 34 - Heredrogram representing the segregation of the *CFTR* gene variants from parents to patient 1.

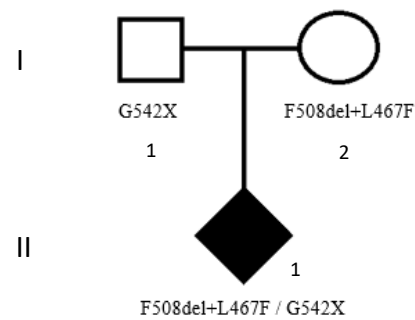

Figure 35 - Heredrogram representing the segregation of the *CFTR* gene variants from parents to patient 2.

Conclusion

The protein produced by the L467-F508del *CFTR* complex allele exhibits severely reduced activity, since the L467F variant of the *CFTR* gene has been reported to be damaging to the maturation of this protein. Consequently, immature, glycosylated *CFTR* protein is insensitive to ETI therapeutic.

The presence of a complex allele does not always affect responsiveness to drugs, however, as was verified through the cases presented here, it is essential to identify the various variants existing in the same allele, as the response to treatment may depend on the combination of existing variants, and thus may require a detailed and careful analysis of each case.

A significant fraction of patients was genetically tested several years ago using standard molecular panels and the molecular diagnosis was completed when two variants of the *CFTR* gene were identified. However, some of these patients could unknowingly carry complex alleles, which in turn may affect the functional mechanism of the protein and its responsiveness to drugs, as in the cases we discussed here. It remains to be determined whether this complex allele, whose actual prevalence is unknown and possibly ethnically variable, should be actively investigated, before deciding on treatment, since it is important to identify non-responders, for its relevant economic impact on healthcare systems.

4. Hypertrophic Cardiomyopathy

Hypertrophic cardiomyopathy (HCM) is an autosomal dominant disease with variable penetrance and expression. It's characterized by an increased left-ventricle (LV) wall thickness, and is a major cause of arrhythmic sudden death, heart failure, and atrial fibrillation (Schouten, et al., 2002), (Hensley, et al., 2015).

More than 1400 genetic mutations causing HCM have been found to date, indicating that it is a disease with significant genetic variability; however, there is some variants that are more common, specifically, in 8 genes that code for sarcomere component proteins. Approximately 70% of cases are caused by mutations in the *MYH7* and *MYBPC3* genes. About 60% of those patients have a family history of HCM (Schouten, et al., 2002), (Hensley, et al., 2015).

4.1. Diagnosis of HCM

The diagnosis of HCM is frequently made through a combination of tests, more often by non-invasive cardiac imaging, echocardiography and/or cardiac magnetic resonance imaging. Other elements could be, electrocardiograms, stabilisation of a family history of cardiovascular disease (about 3 generations) and, if possible, genetic testing (ESC Guidelines on Hypertrophic Cardiomyopathy, 2014), (Hershberger, et al., 2018), (Ommen, et al., 2020).

Genetic testing is critical in the diagnosis of HCM patients and their families. It is carried out using a variety of methods, including custom gene panels or WES (silico panel). A gene panel is usually conducted, with the most prevalent genes causing HCM. The proband is always analysed first, and if the panel does not reveal any variants, WES can be performed. Cascade genetic testing should be given to family members at immediate risk, after finding an individual with HCM and a pathogenic or likely pathogenic variant. If a variant of uncertain significance (VUS) is discovered, family members should be closely monitored (Hershberger, et al., 2018), (Ommen, et al., 2020), (Maron, 2018).

Individuals with a pathogenic variant but no symptoms require continuous cardiac monitoring due to phenotypic variability in illness and variability on time of onset and progression (Ommen, et al., 2020).

4.2. Clinical Case

Ferreira Family

The Ferreira family was studied for possible variants in the genes that cause HCM, since the individual II-3 (proband) was found to have hypertrophic cardiomyopathy, caused by the two most common and severe mutations *MYH7* and *MYBPC3*.

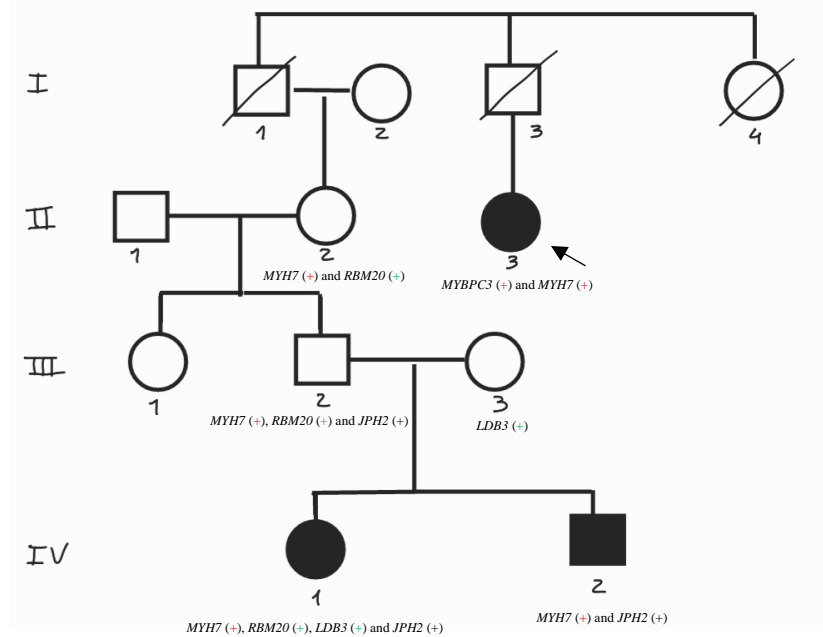

Figure 36 - Ferreira family heredogram (4 generations).

NGS analysis of the following panel of genes was performed:

ACTC1, ACTN2, ALPK3, BRAF, CALR3, CAV3, CARYAB, CSRP3, GLA, JPH2, LAMA4, LAMP2, MAP2K1, MYBPC3, MYH7, MYL2, MYL3, MYLK2, MYOZ2, MYPN, NEXN, PDLIM3, PLN, PRKAG2, RAF1, SOS1, TCAP, TNNC1, TNNI3, TNNT2, TPM1, TTR, VCL.

Only genes associated with the clinical condition under study, hypertrophic cardiomyopathy, were examined. Sanger sequencing of the identified pathogenic variants

was also conducted, for confirmation. The data gathered was analysed using an informatic software, international databases, and the most recent recommendations.

Results

Pathogenic (red), benign (green) and VUS (black) variants found in Ferreira family members:

- **II-2** – *MYH7* (+) and *RBM20* (+).
- **II-3** (Proband) – *MYBPC3* (+) and *MYH7* (+).
- **III-2** – *MYH7* (+), *RBM20* (+) and *JPH2* (+).
- **III-3** – *LDB3* (+).
- **IV-1** – *MYH7* (+), *RBM20* (+), *LDB3* (+) and *JPH2* (+).
- **IV-2** – *MYH7* (+) and *JPH2* (+).

Interpretation of the results

The study began with the woman **II-3** (proband), who had hypertrophic cardiomyopathy, and was discovered with the two most common and severe mutations causing hypertrophic cardiomyopathy, *MYH7* and *MYBPC3*.

The woman **II-2**, was also studied since she was a direct cousin of the proband. It was discovered that she had a mutation in the *MYH7* gene. The family study ended here, however, despite this lady being asymptomatic (at the moment of the study), she was a carrier of a causative pathogenic variant, and thus, she could still present in the future, symptoms of hypertrophic cardiomyopathy, so she should be subjected to cardiac monitoring.

The individuals **IV-1** and **IV-2** were diagnosed with hypertrophic cardiomyopathy shortly after birth. As a result, the NGS sequencing study of these two individuals and their parents, **III-2** and **III-3**, highlighted the presence of the variant c.5302G>A p.(Glu1768Lys) in the gene *MYH7* and c.1975G>A p.(Ala659Thr) in the gene *JPH2* in heterozygous state in individuals **III-2**, **IV-1** and **IV-2**, revealing that the individual **III-2**, son of **II-2**, acquired the identical mutation from his mother and was likewise asymptomatic (at the moment of the study).

The mutation c.5302G>A p.(Glu1768Lys) in the *MYH7* gene, occurs in a functional region of the protein, and so, was categorized as maybe pathogenic by the computer

software, but it was described as probably pathogenic in a published case of a person with hypertrophic cardiomyopathy. However, at the time of this study, this variation was classified as being VUS in the Clinvar database, according to the most recent recommendations on the interpretation and classification of *MYH7* gene variants.

The variant c.1975G>A p.(Ala659Thr) in the *JPH2* gene is not present in the dbSNP database nor mentioned in the literature; it is located in a functional region of the protein, and pathogenicity prediction tools classify it in different ways. According to the recommendations on variation interpretation and classification, it should be regarded as VUS.

The two affected offspring of these parents, **IV-1** and **IV-2**, inherited the same mutation (*MYH7*) present in the father, **III-2**, but, differently from the father, they had symptoms since they were one year old. In addition to this pathogenic variation discovered in the *MYH7* gene, benign variants in the *RBM20* and *LDB3* genes, and a VUS in the *JPH2* gene, were discovered in these two individuals. As a result, the genetic heterogeneity of this family, together with other genetic and environmental factors, probably affects the phenotypic variability across the individuals.

Conclusion

A whole-exome investigation in the family nucleus component was recommended to identify potential modifier genes. Followed by a cardiac re-evaluation of the individual's carriers of the reported variants, a genetic counselling session was required for interpretation of these data.

5. Hemoglobinopathies

Hemoglobin (Hb) is the protein component of RBCs, responsible for the transportation of oxygen. It's composed by four chains of globins. The main Hb present in healthy adults (in approximately 97%) is HbA1, consisting of two alpha chains and two beta chains ($\alpha\alpha\beta\beta$). Other types of Hb are also present but in smaller proportions: the HbA2 (around 2%) is composed by two alpha chains and two delta chains ($\alpha\alpha\delta\delta$) and HbF (fetal Hb) (present in less than 1%) is composed of two alpha chains and two gamma chains ($\alpha\alpha\gamma\gamma$) (Sabath, 2017).

Hemoglobinopathies are the most common inherited genetic diseases in the world. They are caused by pathogenic variants in the genes responsible for the synthesis of the globin chains of Hb. Hemoglobinopathies can be classified into two types, according with their origin: caused by structural abnormalities or production abnormalities. Structural abnormalities affect the normal functioning of Hb due to an abnormal structure of the globin chains, resulting in a shorter life span of the RBCs. Abnormalities in the synthesis of globin chains, result in reduced rates of Hb production (Sabath, 2017).

5.1. Thalasseмии

Thalasseмии are a heterogeneous group of genetic disorders, with autosomal recessive heredity, that result from a decrease in the synthesis of the globin chains (alpha and beta) of Hb. Decreased expression of these genes may result from gene deletions or variants that result in decreased RNA synthesis, processing, stability, etc. The two most frequent thalasseмии, are alpha-thalassemia and beta-thalassemia. The alpha-chains are formed by four alpha-globin genes (*HBA1* and *HBA2*) located on chromosome 16, whereas the beta-chains are produced by two beta-globin genes (*HBB*) situated on chromosome 11. Under typical circumstances, alpha- and beta-chains are formed in equal amounts of protein, but since we have 4 alpha-globin genes and 2 beta-globin genes, gene expression is more active for beta-genes, because they must produce the double amount of protein to balance alpha-globin protein. Depending on the stage of life, from birth to adult life, different kinds of Hb are produced by the conjugation of the various globin chains (α (alpha), β (beta), γ (gamma), δ (delta)) (Borges-Osório & Robinson, 2013),

(Traeger-Synodinos, Hartevelde, Old, & al., 2015), (Ivaldi & Barberio, 2012), (Bajwa & Basit, 2021), (Galanello & Cao, 2011).

5.1.1. Alpha-thalassemia

Alpha-thalassemia is mostly caused by deletions of the alpha-globin genes (*HBA1* and *HBA2*), resulting in reduced or absent production of alpha globin chains. Deletion of a single *HBA* gene is more common, resulting in mild thalassemia phenotype (- alpha/ alpha alpha). More rarely, alpha-thalassemia can originate from point mutations such as single nucleotide substitutions. This disease is very heterogeneous at a molecular and clinical level, and thus the different forms of alpha-thalassemia are related to the pathogenic variants present (Bajwa & Basit, 2021), (Galanello & Cao, 2011).

The transcription rate of the *HBA* genes differs between *HBA1* and *HBA2*, i.e., the *HBA2* gene encodes 2 to 3 times more than the *HBA1* gene. Therefore, this difference in the transcription rate between the two genes has implications for the amount of Hb present and the severity of the alpha-thalassemia forms will also depend on which gene encoding alpha globin chains is affected by the pathogenic variant, *HBA1* or *HBA2* (Bajwa & Basit, 2021), (Galanello & Cao, 2011).

There are different forms of alpha-thalassemia. We can have silent carriers of a variant of alpha-thalassemia, who have a deletion of one of the *HBA* genes (- alpha/alpha alpha). Normally, these individuals are clinically and hematologically normal, with standard values of HbA2 and F, but may be associated with microcytosis and mild hypochromia, which is, respectively, a decrease in the size of RBCs and in the reddish colour of this cells due to a reduction of the Hb (Bajwa & Basit, 2021), (Galanello & Cao, 2011).

Individuals with deletions of two *HBA* genes *in cis* (- -/alpha alpha) or *in trans* (- alpha/- alpha) will be affected by alpha-thalassemia, showing a slight increase in Hb Bart, with normal HbA2 and F values. Couples both heterozygous for these alleles have a 25% risk of having a fetus with Hb Bart hydrops fetalis syndrome (Bajwa & Basit, 2021), (Galanello & Cao, 2011).

Another possible form of alpha-thalassemia is HbH disease which results from the presence of only one functional *HBA* gene (- - / - alpha), resulting in the accumulation of beta globin chains, and consequently their precipitation within the RBCs, which are subsequently destroyed prematurely by the spleen. Affected individuals may present with

moderate to severe hemolysis, microcytosis and splenomegaly (Bajwa & Basit, 2021), (Galanello & Cao, 2011).

Hb Bart hydrops fetalis syndrome, is the most severe form of alpha-thalassemia. It is usually associated with the functional absence of all 4 *HBA* genes (- -/- -). The affected fetus is thus unable to produce alpha-globin chains required to produce HbF or HbA, which are essential for human life, therefore this disease is usually not compatible with postnatal life and affected fetuses are either stillborn or die shortly after birth. Due to the severity of this syndrome and the associated maternal complications, medical termination of pregnancy is recommended (Bajwa & Basit, 2021), (Galanello & Cao, 2011).

5.1.2. Beta-thalassemia

Beta-thalassemia is caused by pathogenic variants on the *HBB* gene, resulting in the reduced or absent beta-globin chains synthesis of the Hb tetramer, which is composed by two alpha-globin chains and two beta-globin chains (alpha alpha/beta beta). It is a very heterogenous disease at the molecular level, and so, more than 200 variants responsible for the disease, have been described. Most of these variants are caused by single nucleotide substitutions (Borges-Osório & Robinson, 2013), (Munkongdee, Chen, Winichagoon, & al., 2020), (Cao & Galanello, 2010).

This disease can be classified into three different clinical and hematological conditions depending on the variant present: beta-thalassemia carrier state, beta-thalassemia intermedia, and beta-thalassemia major.

The beta-thalassemia carrier state results from a heterozygosity for beta-thalassemia trait and is clinically asymptomatic. These patients present mild microcytosis and hypochromia, and increased levels of HbA₂, apart from also imbalances in the synthesis of alpha- and beta-globin chains.

Beta-thalassemia intermedia can range from asymptomatic state to severe with the need of blood transfusions.

Lastly, beta-thalassemia major is the most serious type of beta-thalassemia and these patients have a severe microcytic and hypochromic transfusion-dependent anemia, being also clinically characterized by the presence of an increased number of RBCs and low MCV (mean corpuscular volume) and MCH (mean corpuscular Hb) (Borges-Osório &

Robinson, 2013), (Munkongdee, Chen, Winichagoon, & al., 2020), (Cao & Galanello, 2010).

The clinical severity of beta-thalassemia, results mainly, from the accumulation of alpha-chains, that start to interfere with erythrocyte synthesis, resulting in severe anemia. Defective erythrocytes undergo into hemolysis and are eliminated by macrophages. The accumulation of high amounts of bilirubin, originated from Hb degradation, results in the yellow color in both, eyes, and skin, seen in thalassemia major patients. Pallor, fatigue, tachycardia, cardiac hypertrophy, and splenomegaly are all symptoms of severe anemia. In addition, the attempt by the bone marrow to compensate for the RBC imbalance leads to its hyperactivity, resulting in distinct features such as the growth of bones of the skull and face (Borges-Osório & Robinson, 2013), (Munkongdee, Chen, Winichagoon, & al., 2020), (Cao & Galanello, 2010).

5.2. Diagnosis of Thalassemia

Thalassemia diagnosis, most of the times, starts with the evaluation of a combination of hematological and biochemical tests, that analyse the RBCs size, volume and Hb quantity. When these values are low, a blood smear is also performed to analyse the morphology of the RBCs, if they are small and/or pale, we are in the presence of microcytosis and hypochromia, respectively. Therefore, with these suspicious results, the next step is to carry out a screening by electrophoresis or a HPLC (high-performance liquid chromatography) of the Hbs, which will separate the different proteins that make up the Hb molecule, such as, HbA, HbA2, HbF, etc. After these analysis, if the results remain uncertain, DNA analysis should be considered and performed, to obtain more information or to confirm the diagnosis of thalassemia (Borges-Osório & Robinson, 2013), (Traeger-Synodinos, Harteveld, Old, & al., 2015), (Ivaldi & Barberio, 2012), (Munkongdee, Chen, Winichagoon, & al., 2020), (Cao & Galanello, 2010).

Depending on the type of thalassemia suspected, and consequently the type of variants behind the cause, one can start by performing more targeted techniques, such as, Reverse Dot Blot, for the most common variants in the population from which the affected individual is originated and/or MLPA to identify gene deletions/duplications. If these fail to detect the pathogenic variants, sequence analysis can be performed, for example, with sanger sequencing or NGS (Borges-Osório & Robinson, 2013), (Traeger-Synodinos,

Harteveld, Old, & al., 2015), (Ivaldi & Barberio, 2012), (Munkongdee, Chen, Winichagoon, & al., 2020), (Cao & Galanello, 2010).

Clinical indications for the diagnosis of thalassemia: (Borges-Osório & Robinson, 2013), (Ivaldi & Barberio, 2012)

- High levels of HbF
- Abnormal levels of HbA2
- Microcytosis and Hypochromia
- Familiarity for thalassemia
- Severe anemias

Moreover, during pregnancy, the fetus produces a particular kind of Hb, known as HbF (alpha alpha/gamma gamma), which is the prevalent Hb fraction during fetal life and at birth. After birth, HbF synthesis steadily diminishes and is replaced by adult Hb (alpha alpha/beta beta), so much that the presence of HbF in adults is generally less than 1% after the first year of life, however it increases in the presence of a beta-thalassemia disease (Borges-Osório & Robinson, 2013), (Ivaldi & Barberio, 2012), (Cao & Galanello, 2010).

Therefore, right after birth, is difficult to diagnose thalassemia, since the fetus still have high levels of HbF that will balance and protect the child, in the presence of any anomaly in the synthesis of alpha- or beta-globin chains. However, if the parents find out that they are carriers of thalassemia trait, it is possible to make the diagnosis of thalassemia with molecular genetic testing, that allows the identification of pathogenic variants inherited from the parents in the child (Cao & Galanello, 2010).

Prenatal diagnosis of thalassemia is possible in high-risk pregnancies, in which both partners are carriers, by the analysis of fetal DNA obtained by amniocentesis or CVS. Usually, both parents disease-causing alleles must be identified before the prenatal test. When it's confirmed that a couple is carrier of a pathogenic variant, prenatal diagnosis will give them the reproductive alternative of medical termination of pregnancy or assistance in preparing for the delivery of an affected baby (Traeger-Synodinos, Harteveld, Old, & al., 2015), (Ivaldi & Barberio, 2012), (Cao & Galanello, 2010).

5.3. Clinical Case

Case of a 39-year-old Vietnamese lady, pregnant of 15 weeks, indicated for thalassemia study, since she had an unstudied case of thalassemia in the family.

Methods

The study started, according to the guidelines provided by SITE (Societa' Italiana Talassemie ed Emoglobinopatie), by performing a hemogram or complete blood count (CBC), sideremia and ferritin analysis, and quantification of Hb components by HPLC with two different kits (Bio-Rad, Beta-Thal DualKit and Bio-Rad, Beta-Thal Short), each of which was subsequently analysed with two different versions of Trinity Biotech Premier Hb9210 Resolution software ("quick scan" and "high resolution"), resulting in 4 HPLCs.

The hemogram and HPLC analysis, were followed by a molecular analysis to characterise the suspected abnormal variants, where it was extracted DNA from the peripheral blood sample of the woman in study, and specific DNA fragments were amplified by PCR, more specifically, the sequences referring to the alpha (*HBA1* and *HBA2*) and beta (*HBB*) genes, and them sequenced by sanger sequencing.

Besides the sequencing, considering that the lady under study had an asian origin (vietnamese) and these populations have a high incidence of alpha thalassaemic variants, it was also decided to perform the Reverse Dot Blot technique to search for the presence of the most common alpha thalassaemic variants in these specific populations, since milder forms of alpha thalassemia may be present without a significant alteration of the hemogram parameters.

Results

As we can see in the results obtained from the hemogram, ferritin and sideremia analysis (figure 37), we observed that in general, no particular alterations were observed. It was only verified, that the MCV value was very close to the minimum normal value, but this parameter alone is not an indicator of disease. However, the results of the 4 HPLCs led us to suspect a possible variant in the Hb alpha genes, since the HbA2 values in 3 of the 4 HPLCs are below the minimum normal values.

	Valore osservato	Unità di misura	Valori di riferimento	Aspetto Hb rilevato con i quattro strumenti HPLC			
				1	2	3	4
RBC	4,87	$\times 10^6/\mu\text{L}$	4,0-5,4				
Hb	13,0	g/dL	12,0-14,0				
PCV	40	%	38-47				
MCV	82,2	fL	82-98				
MCH	26,7	pg	25-34				
Sideremia	93	$\mu\text{g/dL}$	37-145				
Ferritina	30	ng/mL	13-150				
HbA ₂		%	2,5-3,2	3,0	1,9	1,8	1,6
HbF		%	< 1,0	0,9	0,6	-	0,1

Figure 37 - Results from the hemogram, sideremia and ferritin analysis, and HPLCs results.

After evaluating the resulting chromatograms from the HPLCs, it was verified an attempted separation of the HbA₂ peak into two, which may suggest the presence of a variant in the alpha-globin chains gene or the effect of a variant in the delta-globin chains gene (figure 38), and on the other, it was observed an asymmetric HbA peak which leads to suspect the possible presence of a variant Hb (figure 39).

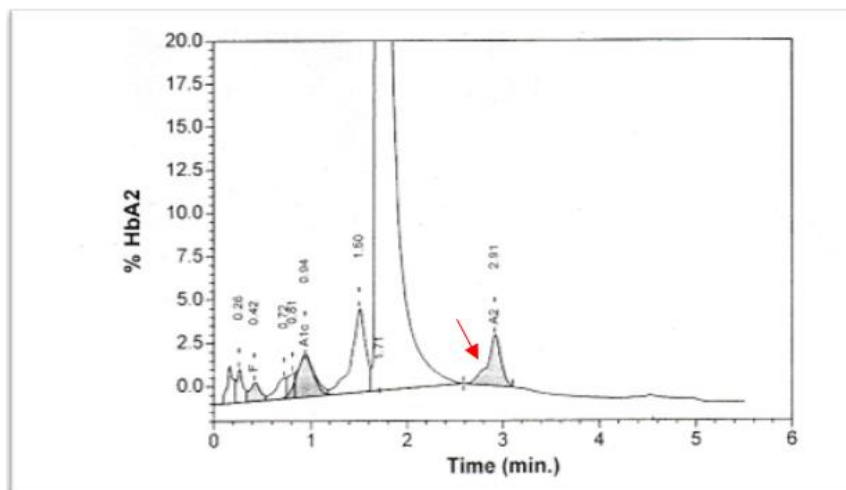

Figure 38 - Resulting HPLC chromatogram.

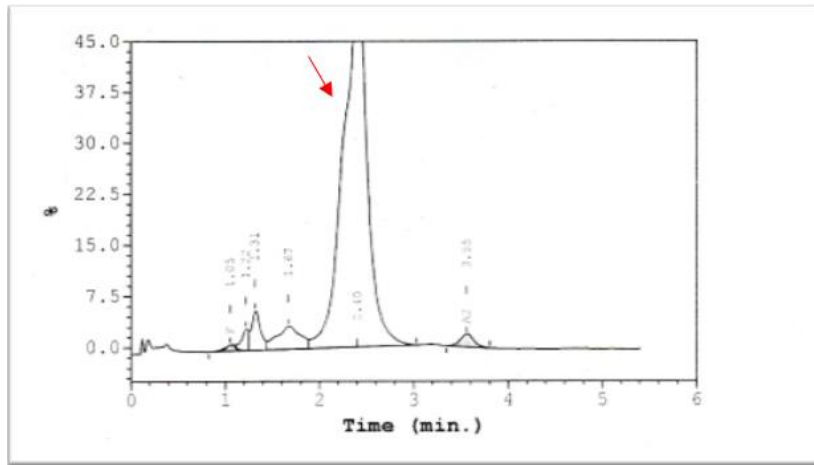

Figure 39 - Resulting HPLC chromatogram.

The molecular analysis showed the presence of a heterozygous variant of the alpha globin chains on the *HBA2* gene (Hb Hekinan alfa2 27(B8) Glu>Asp - *HBA2*:c.84 G>T) (figure 40) and a thalassemic alpha defect (-3.7kb del) *in trans*, on the other allele. The two variants were inherited by this lady from her parents.

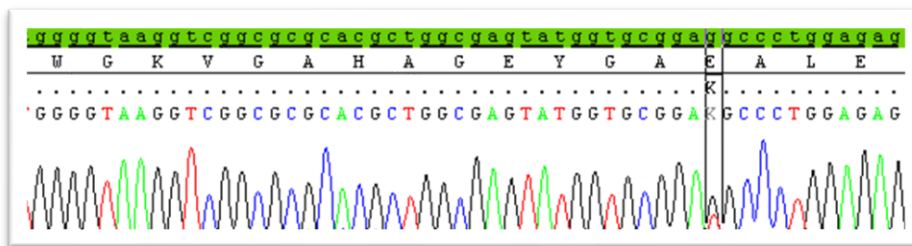

Figure 40 - Sequence of the DNA fragment referent to the *HBA2* gene showing a G>T variant, in the region indicated in this image.

Conclusion

The Hb Hekinan variant is considered to be benign, since it does not cause functional abnormalities.

The alpha thalassemic defect caused by the 3.7 kb deletion that affects both alpha genes, *HBA2* and *HBA1*, results in the production of a functional hybrid *HBA2/HBA1* gene. This variant is very common in the asian population and can also be considered as benign.

In this way, the variants discovered don't produce hematological alterations or known clinical consequences, however, it is recommended to study the partner of this woman to

exclude possible interference with more serious alpha thalassaemic defects, that could be a risk for the fetus.

CONCLUSION

The internship was undoubtedly a very enriching experience, both professionally and personally.

The fact that I did my internship outside Portugal made me grow a lot. I had the opportunity to get to know the culture of another country, to learn a new language, to develop my English, and to meet so many different people from different countries that I know I will carry with me for the rest of my life.

The passage through the human genetics laboratory of the institute Giannina Gaslini was wonderful, besides having learned a lot, both at practical and theoretical level, a very important part of this experience, was without a doubt, the interaction with all the colleagues in the laboratory, who crossed my path and Dr. Domenico, who welcomed me so well, making me feel at home.

Obviously, there were some not so good moments, since, being outside my country, far from family and friends, sometimes we can feel more alone, but without a doubt, the good moments were many more.

The internship allowed me to visualize and experience all the dynamics of a human genetics laboratory and all the work involved. Besides, after this experience, I feel prepared for the challenge of professional life with the certainty that I am in the right profession, although I still have a long way to go.

REFERENCES

- Alberry, M. S., Aziz, E., Ahmed, S. R., & Abdel-Fattah, S. (2021). Non invasive prenatal testing (NIPT) for common aneuploidies and beyond. *European journal of obstetrics, gynecology, and reproductive biology*, 258, 424–429. doi:<https://doi.org/10.1016/j.ejogrb.2021.01.008>
- Ashfield, T., McCready, E., Shago, M., Wang, H., Sinclair-Bourque, E., Cappa, E., . . . Chun, K. (2021). Practice patterns of prenatal and perinatal testing in Canadian cytogenetics laboratories. *Prenatal diagnosis*, 41(7), 843–854. doi:<https://doi.org/10.1002/pd.5951>
- Audibert, F., De Bie, I., Johnson, J. A., Okun, N., Wilson, R. D., Armour, C., . . . Kim, R. (2017). No. 348-Joint SOGC-CCMG Guideline: Update on Prenatal Screening for Fetal Aneuploidy, Fetal Anomalies, and Adverse Pregnancy Outcomes. *Journal of obstetrics and gynaecology Canada : JOGC = Journal d'obstetrique et gynecologie du Canada : JOGC*, 39(9), 805–817. doi:<https://doi.org/10.1016/j.jogc.2017.01.032>
- Baccarani, M., Deininger, W. M., Rosti, G., Hochhaus, A., Soverini, S., & al., e. (2013). European LeukemiaNet recommendations for the management of chronic myeloid leukemia. *Blood*, 122 (6): 872–884. doi:<https://doi.org/10.1182/blood-2013-05-501569>
- Bajwa, H., & Basit, H. (2021). *Thalassemia*. Treasure Island (FL): StatPearls Publishing.
- Bardsley, M. Z., Kowal, K., Levy, C., Gosek, A., Ayari, N., Tartaglia, N., . . . Ross, J. L. (2013). 47,XYY syndrome: clinical phenotype and timing of ascertainment. *The Journal of pediatrics*, 163(4), 1085–1094. doi:<https://doi.org/10.1016/j.jpeds.2013.05.037>
- Barry, P. J., & Taylor-Cousar, J. L. (2021). Triple combination cystic fibrosis transmembrane conductance regulator modulator therapy in the real world – opportunities and challenges. *Current Opinion in Pulmonary Medicine*, 27(6), 554-566. doi:doi: 10.1097/MCP.0000000000000819

- Bayani, J., & Squire, J. A. (2004). Fluorescence in situ Hybridization (FISH). *Current protocols in cell biology*, Chapter 22. doi:<https://doi.org/10.1002/0471143030.cb2204s23>
- Bell, S. C., Mall, M. A., Gutierrez, H., & al., e. (2020). The future of cystic fibrosis care: a global perspective . *The Lancet Respiratory Medicine*, 8(1), 65-124. doi:[https://doi.org/10.1016/S2213-2600\(19\)30337-6](https://doi.org/10.1016/S2213-2600(19)30337-6).
- Bergougnoux, A., Taulan-Cadars, M., Claustres, M., & Raynal, C. (2018). Current and future molecular approaches in the diagnosis of cystic fibrosis. *Expert review of respiratory medicine*, 12(5), 415–426. doi:<https://doi.org/10.1080/17476348.2018.1457438>
- Biancalana, V., Glaeser, D., McQuaid, S., & Steinbach, P. (2015). EMQN best practice guidelines for the molecular genetic testing and reporting of fragile X syndrome and other fragile X-associated disorders. *European journal of human genetics : EJHG*. doi:<https://doi.org/10.1038/ejhg.2014.185>
- Bienvenu, T., & Nguyen-Khoa, T. (2020). Current and future diagnosis of cystic fibrosis: Performance and limitations. *Archives de pediatrie: organe officiel de la Societe francaise de pediatrie*, eS19–eS24. .
- Borges-Osório, M. R., & Robinson, W. M. (2013). *Genética Humana (Portuguese Edition)* (3rd ed. ed.). Artmed.
- Cao, A., & Galanello, R. (2010). Beta-thalassemia. *Genetics in medicine.*, 12(2), 61-76. doi:<https://doi.org/10.1097/GIM.0b013e3181cd68ed>
- Celkan, T. T. (2020). What does a hemogram say to us? *Turk pediatri arsivi*, 55(2), 103–116. doi:<https://doi.org/10.14744/TurkPediatriArs.2019.76301>
- Correll-Tash, S., Conlin, L., Mininger, B. A., Lilley, B., Mennuti, M. T., & Emanuel, B. S. (2018). The Recurrent t(11;22)(q23;q11.2) Can Occur as a Post-Zygotic Event. . *Cytogenetic and genome research*, 156(4), 185–190. doi:<https://doi.org/10.1159/000494648>
- CSS, G. d. (n.d.). “Screening prenatale non invasivo basato sul DNA (Non Invasive Prenatal Testing – NIPT)”. Retrieved 08 09, 2022, from Ministero della Salute: https://www.salute.gov.it/portale/documentazione/p6_2_2_1.jsp?id=2381&lingua=italiano

- Curnow, K. J., Sanderson, R. K., & Beruti, S. (2019). Noninvasive Detection of Fetal Aneuploidy Using Next Generation Sequencing . *Methods in molecular biology*, 1885, 325–345. doi:https://doi.org/10.1007/978-1-4939-8889-1_22
- De Boeck, K. (2020). Cystic fibrosis in the year 2020: A disease with a new face. *Acta paediatrica*, 109(5), 893–899. doi:<https://doi.org/10.1111/apa.15155>
- Dondorp, W., de Wert, G., Bombard, Y., & al., e. (2015). Non-invasive prenatal testing for aneuploidy and beyond: challenges of responsible innovation in prenatal screening. Summary and recommendations. *Eur J Hum Genet*. doi:<https://doi.org/10.1038/ejhg.2015.56>
- Emanuel BS, Zackai EH, & Medne L. (2017, August 31). *Emanuel Syndrome*. (A. MP, Mirzaa GM, & R. Pagon, Eds.) Retrieved July 2022, from GeneReviews.
- ESC Guidelines on Hypertrophic Cardiomyopathy. (2014). *2014 ESC Guidelines on Diagnosis and Management of Hypertrophic Cardiomyopathy*. Retrieved from <https://www.escardio.org/Guidelines/Clinical-Practice-Guidelines/Hypertrophic-Cardiomyopathy>
- Fan, Y. (2010). *Molecular Cytogenetics: Protocols and Applications (Methods in Molecular Biology, 204) (Softcover reprint of hardcover 1st ed. 2003 ed.)*. Humana.
- Flemming, W. (1882). In Zellsubstanz, Kern und Zellteilung. *Vogel*.
- Galanello, R., & Cao, A. (2011). Gene test review. Alpha-thalassemia . *Genetics in medicine : official journal of the American College of Medical Genetics*, 13(2), 83–88. doi: <https://doi.org/10.1097/GIM.0b013e3181fcb468>
- Gardner, M. R., & Amor, D. J. (2018). *Gardner and Sutherland's Chromosome Abnormalities and Genetic Counseling (Oxford Monographs on Medical Genetics) (5th ed.)*. . Oxford: Oxford University Press.
- Gaudin, M., & Desnues, C. (2018). ybrid Capture-Based Next Generation Sequencing and Its Application to Human Infectious Diseases. *Frontiers in Microbiology*. doi:10.3389/fmicb.2018.02924
- Genetica Umana*. (2022, February 25). Retrieved from Gaslini: <https://www.gaslini.org/reparti/genetica-umana/>
- Gersen, S. L., & Keagle, M. B. (2013). *The Principles of Clinical Cytogenetics (3rd ed.)*. . Springer.

- Ghi, T., Sotiriadis, A., Calda, P., Da Silva Costa, F., Raine-Fenning, N., & al., e. (2016). ISUOG Practice Guidelines: invasive procedures for prenatal diagnosis. . *Ultrasound Obstet Gynecol*, 48: 256-268. doi:<https://doi.org/10.1002/uog.15945>
- Gregg, A. R., Skotko, B. G., Benkendorf, J. L., & al., e. (2016). Noninvasive prenatal screening for fetal aneuploidy, 2016 update: a position of the American College of Medical Genetics and Genomics. ACMG Statement. *Genetics in Medicine*. doi:10.1038/gim.2016.97
- Gu, H., Kim, M. J., Yang, D., Song, J. Y., Cho, S. I., Park, S. S., & Seong, M. W. (2021). Accuracy and Performance Evaluation of Triplet Repeat Primed PCR as an Alternative to Conventional Diagnostic Methods for Fragile X Syndrome. *Annals of laboratory medicine* , 41(4), 394–400. doi:<https://doi.org/10.3343/alm.2021.41.4.394>
- Guest, E. M., & Stam, R. W. (2017). Updates in the biology and therapy for infant acute lymphoblastic leukemia. . *Current opinion in pediatrics*, 29(1), 20–26. doi:<https://doi.org/10.1097/MOP.0000000000000437>
- Harraway, J. (2017). Non-invasive prenatal testing. . *Australian family physician*, 46(10), 735–739.
- Hartwig, T. S., Ambye, L., Sørensen, S., & Jørgensen, F. S. (2017). Discordant non-invasive prenatal testing (NIPT) - a systematic review. *Prenatal diagnosis*, 37(6), 527–539. doi:<https://doi.org/10.1002/pd.5049>
- Hastings, R., Howell, R., Dagna, F., Kristoffersson, U., & Cavani, S. (2012). A common European framework for quality assessment for constitutional, acquired and molecular cytogenetic investigations. . *E C A Newsletter.*, 29. 7-25.
- Heim, S., & Mitelman, F. (2015). *Cancer cytogenetics*. (4th ed. ed.). Chichester: Wiley.
- Hensley, N., Dietrich, J., Nyhan, D., Mitter, N., Yee, M. S., & Brady, M. (2015). Hypertrophic cardiomyopathy: a review. *Anesthesia and analgesia*, 120(3), 554–569. doi:<https://doi.org/10.1213/ANE.0000000000000538>
- Hershberger, R. E., Givertz, M. M., Ho, C. Y., Judge, D. P., Kantor, P. F., McBride, K. L., . . . Committee, A. P. (2018). Genetic evaluation of cardiomyopathy: a clinical practice resource of the American College of Medical Genetics and Genomics (ACMG). *Genetics in medicine : official journal of the American College of Medical Genetics*, 20(9), 899–909. doi:<https://doi.org/10.1038/s41436-018-0039-z>

- In Zellsubstanz, Kern und Zellteilung. (1882). *Vogel*.
- Istruzione Operativa 2.30, U. L. (n.d.). "RP-PCR per la sequenza ripetute CGG nel promotore del gene FMR1".
- Istruzione Operativa 2.31, U. L. (n.d.). "mPCR per valutazione stato dil Metilazione del promotore del gene FMR1".
- Istruzione Operativa 2.40, U. L. (n.d.). Devyser per Fibrosi Cistica.
- Istruzione Operativa 2.57, U. L. (n.d.). NGS Devyser per Fibrosi Cistica.
- Ivaldi, G., & Barberio, G. (2012). Raccomandazioni per la diagnostica di primo livello delle emoglobinopatie. *Società Italiana Talassemie ed Emoglobinopatie: SITE. Collana Scientifica S.I.T.E. n°1*.
- Jabbour, E., & Kantarjian, H. (2018). Chronic myeloid leukemia: 2018 update on diagnosis, therapy and monitoring. . *Am J Hematol.*, 93: 442– 459. doi:<https://doi.org/10.1002/ajh.25011>
- Kanzi, A. M., San, J. E., Chimukangara, B., & al., e. (2020). Next Generation Sequencing and Bioinformatics Analysis of Family Genetic Inheritance. *Frontiers in Genetics*, 11, 1664-8021. doi:10.3389/fgene.2020.544162
- Lee, J., Park, J. K., Kim, D. S., Lee, H. S., Choi, S. I., & Cho, Y. G. (2015). Detailed analysis of isodicentric Y in a case with azoospermia and 45,x/46,x,idic(Y) mosaicism. *Annals of clinical and laboratory science*, 45(2), 206–208.
- Lejeune, J., Gautier, M., & Turpin, R. (1959). Étude des chromosomes somatiques de neuf enfants mongoliens. *C.R.*
- Levy, B. (2019). *Prenatal Diagnosis* (2nd ed. ed.). Humana Press.
- Li, M., & Pinkel, D. (2006). Clinical cytogenetics and molecular cytogenetics. . *J Zhejiang Univ Sci B* 7., 162-3.
- Liehr, T., & Springer-Verlag GmbH. (2013). Fluorescence In Situ Hybridization (FISH). *Springer Publishing*.
- Liehr, T., Cirkovic, S., Lalic, T., & et al. (2013). Complex small supernumerary marker chromosomes – an update. *Mol Cytogenet* 6, 46. doi:<https://doi.org/10.1186/1755-8166-6-46>
- Liehr, T., Ewers, E., Kosyakova, N., Klaschka, V., Rietz, F., Wagner, R., & Weise, A. (2009). Handling small supernumerary marker chromosomes in prenatal diagnostics. *Expert Review of Molecular Diagnostics*, 9:4, 317-324., doi:10.1586/erm.09.17

- Liehr, T., Othman, M. A., Rittscher, K., & Alhourani, E. (2015). The current state of molecular cytogenetics in cancer diagnosis. . *Expert review of molecular diagnostics*, 15(4), 517–526. doi:<https://doi.org/10.1586/14737159.2015.1013032>
- Liehr, T., Williams, H. E., Ziegler, M., Kankel, S., Padutsch, N., & Al-Rikabi, A. (2021). Small supernumerary marker chromosomes derived from chromosome 14 and/or 22. . *Molecular cytogenetics*, 14(1), 13. doi:<https://doi.org/10.1186/s13039-021-00533-6>
- Mardis, E. R. (2013). Next-generation sequencing platforms. . *Annual review of analytical chemistry* , 6, 287–303. doi:<https://doi.org/10.1146/annurev-anchem-062012-092628>
- Maron, B. J. (2018). Clinical Course and Management of Hypertrophic Cardiomyopathy. *New England Journal of Medicine* , 379(7), 655–668. doi:<https://doi.org/10.1056/nejmra1710575>
- Mascarello, J. T., Hirsch, B., Kearney, H. M., Ketterling, R. P., Olson, S. B., Quingley, D. I., . . . Working Group of the ACMG. (2011). Section E9 of the American College of Medical Genetics technical standards and guidelines: fluorescence in situ hybridization. *Genetics in medicine: official journal of the American College of Medical Genetics*, 13(7), 667–675. doi:<https://doi.org/10.1097/GIM.0b013e3182227295>
- Mila, M., Alvarez-Mora, M. I., Madrigal, I., & Rodriguez-Revenga, L. (2018). Fragile X syndrome: An overview and update of the FMR1 gene. *Clinical genetics*, 93(2), 197–205. doi:<https://doi.org/10.1111/cge.13075>
- Ministero della Salute, G. d. (2015). *Linee-Guida Screening prenatale non invasivo basato sul DNA (Non Invasive Prenatal Testing – NIPT)*. Retrieved from https://www.salute.gov.it/portale/documentazione/p6_2_2_1.jsp?id=2381&lingua=italiano
- Monaghan, K., Lyon, E., & Spector, E. (2013). ACMG Standards and Guidelines for fragile X testing: a revision to the disease-specific supplements to the Standards and Guidelines for Clinical Genetics Laboratories of the American College of Medical Genetics and Genomics. *Genet Med*, 15, 575-586. doi:<https://doi.org/10.1038/gim.2013.61>

- Munkongdee, T., Chen, P., Winichagoon, P., & al., e. (2020). Review: Update in Laboratory Diagnosis of Thalassemia . *Frontiers in Molecular Biosciences*. doi:10.3389/fmolb.2020.00074
- Muzzey, D., Evans, E. A., & Lieber, C. (2015). Understanding the Basics of NGS: From Mechanism to Variant Calling. *Current genetic medicine reports*, 3(4), 158–165. doi:https://doi.org/10.1007/s40142-015-0076-8
- Nowell, P. C., & Hungerford, D. A. (1960). A minute chromosome in human chronic granulocytic leukemia. . *Science*.
- Nussbaum, R. L., McInnes, R. R., Willard, H. F., & Hamosh, A. (2007). *Thompson and Thompson Genetics in Medicine (7th ed.)*. Saunders Elsevier.
- Ommen, S. R., Kittleson, M., Link, M. S., Maron, M. S., Martinez, M. W., Miyake, C. Y., . . . al., e. (2020). 2020 AHA/ACC Guideline for the Diagnosis and Treatment of Patients With Hypertrophic Cardiomyopathy. *Circulation*, 142(25). doi:https://doi.org/10.1161/cir.0000000000000937
- Ozdemir, O., Gul, E., Kilicarslan, H., Gokce, G., Beyaztas, F. Y., Ayan, S., & Sezgin, I. (2007). SRY and AZF gene variation in male infertility: a cytogenetic and molecular approach. *International urology and nephrology*, 39(4), 1183–1189. doi:https://doi.org/10.1007/s11255-006-9116-3
- Prenatal Screening and Diagnostic Testing for Fetal Chromosomal and Genetic Conditions*. (n.d.). Retrieved from RANZCOG - Statements & Guidelines: <https://ranzcog.edu.au/statements-guidelines>
- Rack, K. A., van den Berg, E., Haferlach, C., & al., e. (2019). European recommendations and quality assurance for cytogenomic analysis of haematological neoplasms. *Leukemia* 33, 1851–1867. doi: https://doi.org/10.1038/s41375-019-0378-z
- Rafeeq, M. M., & Murad, H. (2017). Cystic fibrosis: current therapeutic targets and future approaches . *Journal of translational medicine*, 15(1), 84. doi:https://doi.org/10.1186/s12967-017-1193-9
- Ribeiro, I. P., Carreira, I. M., & Melo, J. B. (2018). Abordagens Citogenéticas e Genómicas: Perspetiva no Diagnóstico em Oncologia e nas Patologias do Neurodesenvolvimento. *Revista Internacional Em Língua Portuguesa*, (34), 149–172. doi:https://doi.org/10.31492/2184-2043.RILP2018.34/pp.149-172
- Rose, N. C., Kaimal, A. J., Dugoff, L., Norton, M. E., Bulletin, A. C., & Medicine., O. o.-F. (2020). Screening for Fetal Chromosomal Abnormalities. *Obstetrics &*

doi:<https://doi.org/10.1097/aog.0000000000004084>

- Sabath, D. E. (2017). Molecular Diagnosis of Thalassemias and Hemoglobinopathies: An ACLPS Critical Review . *American journal of clinical pathology*, 148(1), 6–15. doi:<https://doi.org/10.1093/ajcp/aqx047>
- Salcedo-Arellano, M. J., Hagerman, R. J., & Martínez-Cerdeño, V. (2020). Fragile X syndrome: clinical presentation, pathology and treatment. Síndrome X frágil: presentación clínica, patología y tratamiento. *Gaceta medica de Mexico*, 156(1), 60–66. doi:<https://doi.org/10.24875/GMM.19005275>
- Saldarriaga, W., González-Teshima, L. Y., Forero-Forero, J. V., Tang, H. T., & Tassone, F. (2021). Mosaicism in Fragile X syndrome: A family case series. *Journal of intellectual disabilities*. doi:<https://doi.org/10.1177/1744629521995346>
- Sandberg, A. A., & Meloni-Ehrig, A. M. (2010). Cytogenetics and genetics of human cancer: methods and accomplishments. . *Cancer genetics and cytogenetics*, 203(2), 102–126. doi:<https://doi.org/10.1016/j.cancergencyto.2010.10.004>
- Schouten, J. P., McElgunn, C. J., Waaijer, R., Zwiijnenburg, D., Diepvens, F., & Pals, G. (2002). Relative quantification of 40 nucleic acid sequences by multiplex ligation-dependent probe amplification. *Nucleic Acids Research*, e57.
- Schreck, R. R., & Distèche, C. M. (2001). Chromosome banding techniques. *Current protocols in human genetics, Chapter 4, Unit4.2*. doi:<https://doi.org/10.1002/0471142905.hg0402s00>
- Seth, R., & Singh, A. (2015). Leukemias in Children. *Indian journal of pediatrics*, 82(9), 817–824. doi:<https://doi.org/10.1007/s12098-015-1695-5>
- Sozzi, G., Testi, M. A., & Croce, C. M. (1999). Advances in cancer cytogenetics. . *Journal of cellular biochemistry, Suppl 32-33*, 173–182. doi:[https://doi.org/10.1002/\(sici\)1097-4644\(1999\)75:32+<173::aid-jcb21>3.0.co;2-g](https://doi.org/10.1002/(sici)1097-4644(1999)75:32+<173::aid-jcb21>3.0.co;2-g)
- Sun, M., Zhang, H., Xi, Q., Li, L., Hu, X., Zhang, H., & Liu, R. (2020). Molecular characterization of small supernumerary marker chromosomes derived from chromosome 14/22 detected in adult women with fertility problems: Three case reports and literature review. *Medicine*, 99(40). doi:<https://doi.org/10.1097/MD.00000000000022532>

- Swansbury, J. (2003). *Cancer Cytogenetics: Methods and Protocols (Methods in Molecular Biology, Vol. 220) (1st ed.)*. . Humana Press.
- Tjio, H., & Levan, A. (1956). The chromosome numbers of man. *Hereditas* 42, 1-6.
- Traeger-Synodinos, J., Harteveld, C., Old, J., & al., e. (2015). EMQN Best Practice Guidelines for molecular and haematology methods for carrier identification and prenatal diagnosis of the haemoglobinopathies. *Eur J Hum Genet* 23, 426–437. doi:<https://doi.org/10.1038/ejhg.2014.131>
- Treating Chronic Myeloid Leukemia by Phase*. (2021, November 24). Retrieved from American Cancer Society: <https://www.cancer.org/cancer/chronic-myeloid-leukemia/treating/treating-by-phase.html>
- Turnpenny, P. D., & Ellard, S. (2017). *Emery's elements of medical genetics* (15th ed. ed.). Elsevier.
- UOC Laboratorio Genetica Umana . (n.d.). “Istruzione Operativa 2.8 – Fase Analitica: Fluorescent in Situ Hybridization (FISH)”.
- Volpi, E. V., & Bridger, J. M. (2008). FISH glossary: an overview of the fluorescence in situ hybridization technique. *BioTechniques*, 45(4), 385–409. doi:<https://doi.org/10.2144/000112811>
- Volpi, E. V., & Bridger, J. M. (2008). FISH glossary: an overview of the fluorescence in situ hybridization technique. . 385–409. doi:<https://doi.org/10.2144/000112811>
- Waldeyer, W. (1888). Über Karyokinese und ihre Beziehung zu den Befruchtungsvorgängen. *Arch. Mikr. Anat.*, 32, 1.
- Wan, T. S. (2017). Cancer Cytogenetics: An Introduction. . *Methods in molecular biology (Clifton, N.J.)*, 1541, 1–10. doi:https://doi.org/10.1007/978-1-4939-6703-2_1
- What Is Childhood Leukemia?* (n.d.). Retrieved 03 30, 2022, from cancer.org.
- Wolff, D. J., Bagg, A., Cooley, L. D., Dewald, G. W., Hirsch, B. A., Jacky, P. B., . . . Committee, A. C. (2007). Guidance for fluorescence in situ hybridization testing in hematologic disorders. *The Journal of molecular diagnostics : JMD*, 9(2), 134–143. doi:<https://doi.org/10.2353/jmoldx.2007.060128>
- Yang, Y., & Hao, W. (2019). Clinical, cytogenetic, and molecular findings of isodicentric Y chromosomes. *Mol Cytogenet* , 12, 55. doi:<https://doi.org/10.1186/s13039-019-0465-x>

- Yohe, S., & Thyagarajan, B. (2017). Review of Clinical Next-Generation Sequencing. *Arch Pathol Lab Med* 1 November, 141 (11): 1544–1557. doi:<https://doi.org/10.5858/arpa.2016-0501-RA>
- Yu, X. W., Wei, Z. T., Jiang, Y. T., & Zhang, S. L. (2015). Y chromosome azoospermia factor region microdeletions and transmission characteristics in azoospermic and severe oligozoospermic patients. *International journal of clinical and experimental medicine*, 8(9), 14634-14646.